

Importance of WAD, Drive train and steering system in a Formula Student Vehicle.

Sayee Deshpande¹, Pranav Khaladkar²

¹B.E Department of Mechanical Engineering, Smt. Kashibai Navale College of Engineering, Pune.

² B.E Department of Mechanical Engineering, Smt. Kashibai Navale College of Engineering, Pune.

Abstract -This document outlines the design and development of the drivetrain for the electric car. Background research on various drivetrain components and testing methodologies was undertaken, which resulted in the formulation of our drivetrain's design criteria. The specs of the components that will be integrated into our drivetrain design are compiled in this paper. The appendices provide all component calculations and specifications. A detailed production plan details the adjustments required to build critical components such as the gearbox. The assembly plan outlines a step-by-step procedure for arranging the components to ensure a safe and functional drivetrain unit. Our drivetrain design will be tested through a series of static and dynamic tests to ensure that all design requirements are met.

In recent times, Power steering and other modes are being upgraded for a better user experience. Similarly, the steering system is a vital aspect of the vehicle and serves as the foundation for the vehicle's performance. It also aids in improving and optimising the driving experience of the driver or user. The steering system of the vehicle finally harnesses the effectiveness of the vehicle's power train and drive train. The primary goal of this thesis is to highlight the design procedures, methodologies, and tools utilised for analysis, as well as to test it for precise validation of the steering system used in a Formula Student Vehicle.

After researching and observing several steering systems, a rack and pinion steering system based on driver input and some other technological characteristics was developed. The steering mechanism followed all of the Formula Student event rules and regulations governing driver and car safety.

Key Words: Steering, Ackerman Geometry, Anti-ackerman geometry, steering layout.

1.INTRODUCTION

A Formula Student vehicle's performance in events like Autocross and skidpad, where there are abrupt bends and time constraints, is entirely dependent on how the wheels respond to the driver's directional shift inputs. It should have an effective and optimal directional reaction, which requires a robust steering system. The rack and pinion steering system has various advantages, including a very basic and simple design and the preservation of internal

damping. A good steering system is one in which the driver's effect is minimal and maneuverability is easy.

In the event that power steering is not permitted, we must devise a method for the car to complete a full turn by only twisting the steering wheel halfway. Hence there are some ways to achieve that, like keeping the steering ratio as less as possible. Also, there are 2 geometries in the steering mechanism which one can incorporate- Ackerman and Anti-ackerman geometry. Anti-ackerman geometry was used to improve the vehicle's performance at sharp turns.

The goal was to operate the formula student electric car with a dependable drivetrain system and a light weight wheel assembly system to improve the vehicle's dynamics performance.

Previously, automobiles' drivetrains were developed with the output of the combustion powertrain in mind, but this year we must design the drivetrain with the electric powertrain in mind. To do so, we must construct the gearbox to produce the appropriate torque. To reduce unsprung mass in a wheel assembly system, the weight of the wheel assembly must be reduced. To do this, we changed the substance of the wheel assembly system and sifted from EN to Al.

Firstly we'll discuss the design of the steering system completely and then shift to WAD and Drive train.

2.COMPARISON BETWEEN ACKERMAN AND ANTI-ACKERMAN GEOMETRY

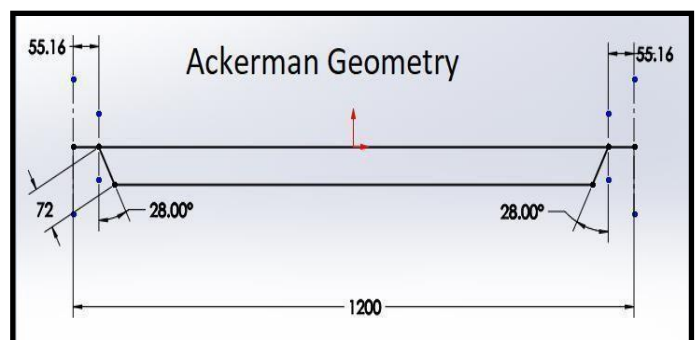

Chart-1: Ackerman Geometry

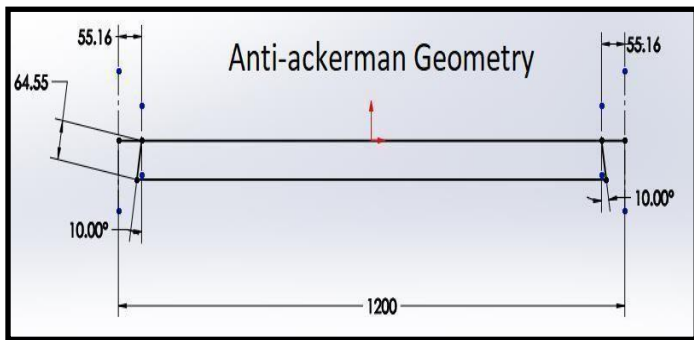

Chart-2:Anti-ackerman Geometry

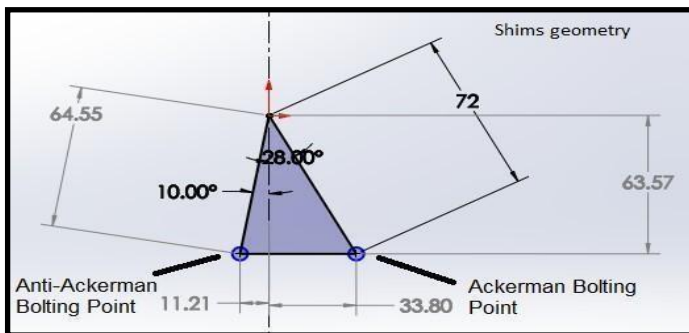

Chart-3:Boting point

Basically, this is the difference between the Ackerman geometry and anti-ackerman geometry. The difference is highlighted in the charts listed above. Further, the difference in the bolting points in both the geometries is also showed. Hence, one can easily decide that which type of is more suitable and beneficial for their vehicle or respective application.

2.RACK AND PINION STEERING SYSTEM

This technique is straightforward and user-friendly. This is the most effective and, as a result, extensively employed drive system by auto makers worldwide. It is widely acknowledged to be the fairest solution to utilise. A pinion at the end of the steering column meshes with the rack to form the mechanism. At one end, the pinion is attached to the steering column. It engages with the rack, which slides to the left or right based on the location of the pinion.

2.1TIE ROD

For the tie rod, we chose AISI 1018 steel for manufacturing- Reasons to choose AISI 1018 material- According to our estimates, it can withstand all of the stresses in the steering system without failing. The tyre rod buckles as a result of forces exerted on the tie rod. The tie rod can withstand a maximum buckling force of 3,099N without failing. Accordingly, AISI1018 was chosen.

Rod end bearings serve to compensate for angular imbalance across contact surfaces at the ends of cylinders, links, rods, and shafts. They are made up of a spherical inner ring and a cylindrical bore for shaft installation. Rod end bearings are employed in applications where there is a minimal to moderate amount of axis distortion.

2.2RACK AND PINION HOUSING

After selecting to install a rack and pinion steering system, we went through several iterations for the major components, namely the rack and pinion. The rack and pinion housing, which houses the components, was the next priority. The dynamic forces were used to create the rack and pinion. Furthermore, there were several critical elements to consider when building the rack and pinion housing. The primary goal is to keep the housing lightweight and compact enough to assure proper operation. AL6061 was utilised to make it lightweight. We must provide slots for the bearings in order for the gear to function properly.

Following iterations were performed to make it more compact.

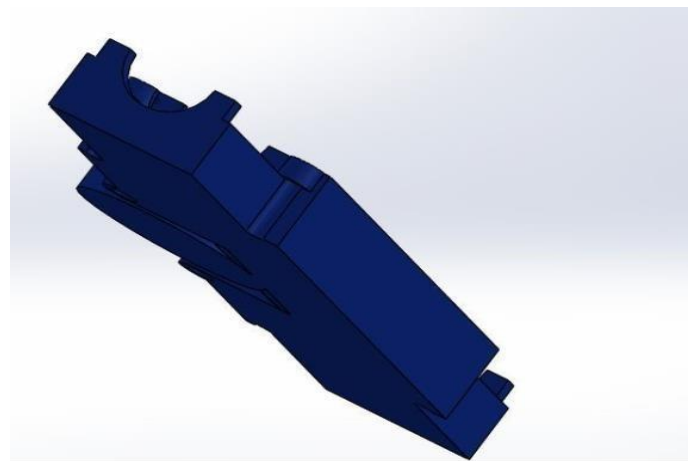

Chart-4:Iteration1

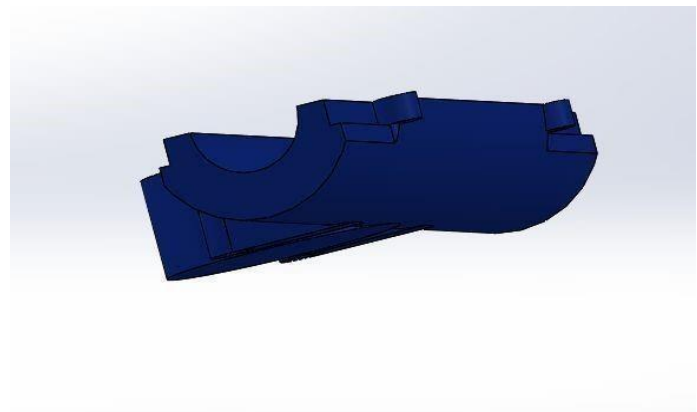

Chart-5:Iteration 2

The weights in the preceding iterations were 179.24 and 133.67, respectively. Finally, the iteration with less weight was chosen. We employed Linear Ball Bearings to achieve smooth motion between the rack and pinion housing, as well as to reduce friction between the two components. It serves as the connector between the rack and the tyres. This is utilised to convey the motion of the rack to the tyre. For the tie rod, we chose AISI 1018 steel for manufacturing- Reasons to choose AISI 1018 material- According to our estimates, it can withstand all of the stresses in the steering system without failing. The tyre rod buckles as a result of forces exerted on the tie rod. The tie rod can withstand a maximum buckling force of 3,099N without failing. Accordingly, AISI1018 was chosen.

2.3 ACCESSORIES

We built a rack connector made of mild steel for easy excess. This is used to join rack and tie rods using rod end bearings. The following goals were kept in mind when designing the connector which was to retain the forces acting on it going. Square Members on the car's steering system are used to mount various gear housing brackets. Different sizes and thicknesses of square members were considered, and the best one was picked appropriately. Mild steel was used. It To mount the Bevel Gear Housing To mount the Rack and Pinion Housing. A steering column is employed. The rotational motion of a bevel pinion is transferred to a rack pinion. For the construction of the columns, we chose mild steel. Reasons for deciding on mild steel. Mild steel, according to our calculations, can be used to make columns since it can withstand all forces without failing. Mild steel is also more resistant to wear.

We employed bevel gear to achieve a 45-degree inner angle for the tyres. We could accomplish the inner angle using universal joints, but to manoeuvre the vehicle, the driver would have to rotate the steering wheel at a considerably larger angle than with the bevel gear arrangement, which is problematic because it is fully strapped. For connection, a bevel gear assembly is employed instead of a universal joint. The steering ratio is reduced when a bevel gear arrangement is used. Bevel gear is intended for a gear ratio of 1.5. We can attain the best steering ratio by employing bevel gear. The steering ratio changes after installing bevel gears. Both the bevel gear and the pinion are made of EN19 material. Targets needed to achieve when designing the housing were as follows- Smooth functioning of Bevel gear pair, Light weight, to fit in the internal cockpit template.

3. QUICK RELEASE HUB

The Quick Release Hub connects and transfers torque from the steering wheel to the shaft. The quick release bearing is used to quickly detach the steering wheel from the flange. The quick release bearing is self-designed with a three-hole layout. It is 2.67 inches thick and has an M6 bolt that connects to the steering wheel.

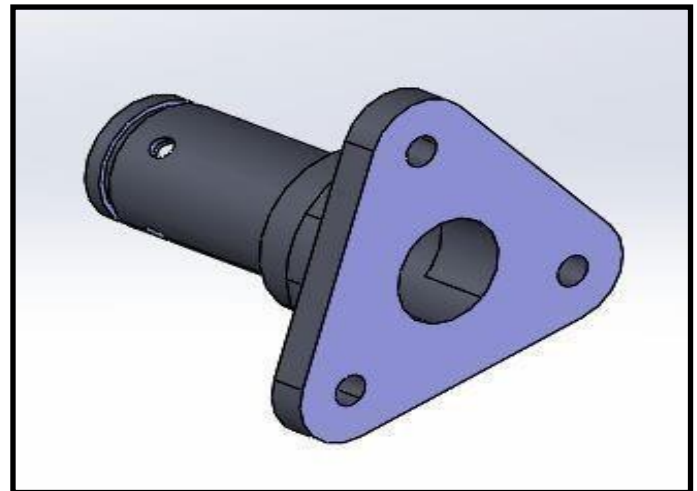

Chart-6: Quick Release Hub

4. STEERING WHEEL

Its purpose is to transfer forces from the driver to the entire system. It is used to steer the car and control it. A 3D printed wheel covered in two layers of carbon fibre. Self-designed and built near oval with outside parameter profile having some straight section.

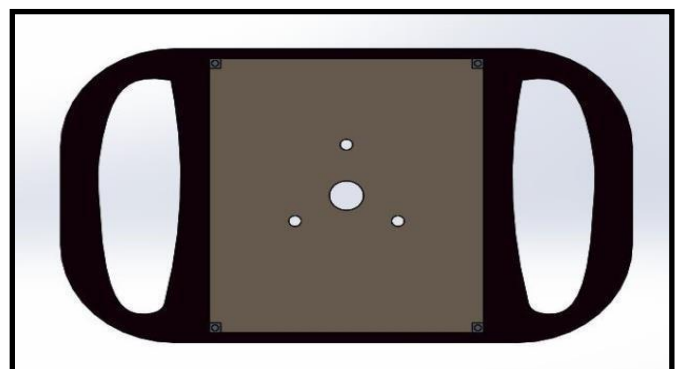

Chart-7: Steering wheel

Now, we'll look at the design of the WAD and drive trains' key components.

3. GEARBOX

The Gearbox is designed to amplify the initial motor torque (i.e. 65Nm) with a reduction ratio of 2.29; in order to meet our requirements, we had to employ. A gearbox is made up of several primary components, including: casing (head and base), driving gear, driven gear, and bearings. The design and selection of Spur gear and gear-shaft has a significant impact on the gearbox's reliability. Spur gears are chosen for their great load carrying ability, smooth operation, and simple construction. To make the assembly more compact and

reliable, the gear and shaft were built as single components; machinability is another significant factor.

The material utilised was EN36, and the production processes included milling, gear shaping, and hobbing.

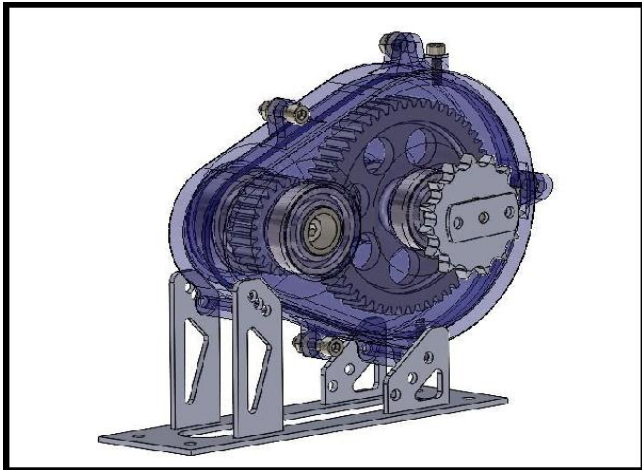

Chart-8:Gearbox

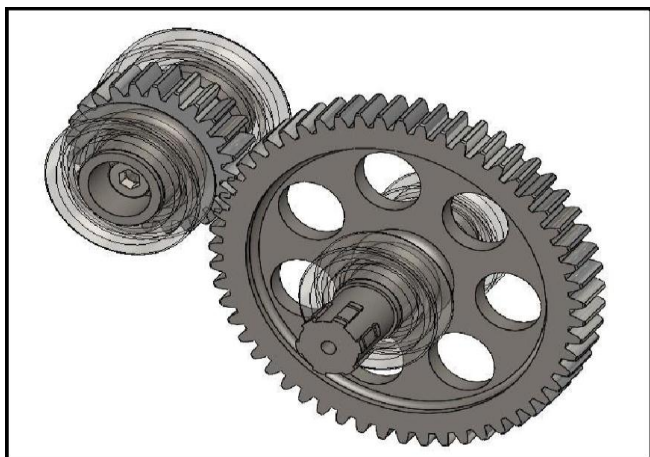

Chart-9:Gear Meshing

5.CHAIN AND SPROCKET

See the following features and why we chose chain drive for our transmission. For our transmission, we chose the 428X chain drive.

Why the 428 x chain...?

Because of the following reasons, the 428X chain was chosen over the 480 O Chain:

Simple upkeep The X ring chain is twice as durable as the O ring chain. As it resists being squished, the X ring twists rather than deforms.

Sprocket life is extended since it does not become stiff.

When we compared all types of drives, we compared

Chain Name	428x
no. of links	66
pitch	12.7mm
roller diameter	7.77mm
roller width	5.207mm
plate thickness	1.47mm
pin diameter	3.96mm
plate height	11.60mm

6.SPOOL DIFFERENTIAL

Our Department's main goal in selecting the differential was to find a reliable, light-weight differential with great performance characteristics. By using the Spool differential, which is dependable, compact, and lightweight, with a straightforward design. Because the motor torque is lower this year, the spool differential meets the torque requirement by transferring 100% of torque to both wheels.

We were previously using Quaife ATB gear type LSD, which transfers 50% of torque to each wheel in normal conditions and improves vehicle performance in all conditions. The weight of LSD is greater than that of spool.

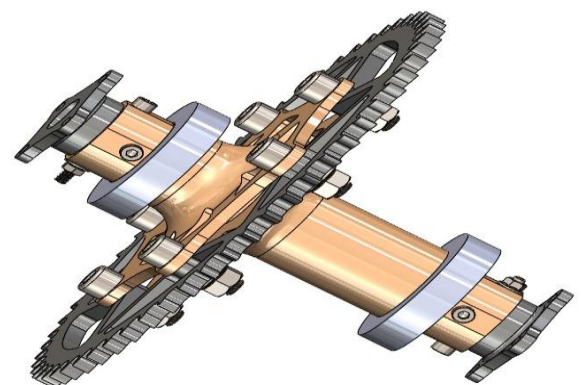

Chart-10:Spool Differential

7.TRIPOD JOINT

To transfer torque from the differential assembly to the shafts, a constant velocity joint that allows for certain angular articulation as well as plunging motion for stability was chosen. Constant-velocity joints were chosen because they allow the drive shaft to transmit power through a

variable angle at a constant rotational speed while minimising friction and play.

After researching and comparing various CV Joints such as the R-Zeppa joint, Tracta joint, Ball type joints, Inboard and Outboard joints, the Tripod CV Joint was chosen because it allowed for required angular articulation and sufficient plunging while maintaining constant rotational speed.

Spider Bearing assembly enables plunging in tripod type CV joint. It is made up of a central drive component known as the Spider. The Spider has been installed on the shaft. Each spider leg is equipped with three Al 7075 Tripod bearings.

Tripod Joint Advantages: Tripods can plunge in and out with a greater distance than suspension moves. A typical tripod joint has a plunge travel of up to 50 mm.

It has a maximum angular articulation of nearly 23 degrees, allowing for transmission at various angles. It is less expensive and much more efficient. The CV cup material is changed from stainless steel to Aluminium 7075 T-6, which can withstand all forces acting on it. A single Cv Cup has been reduced in weight from 960gms to 500gms.

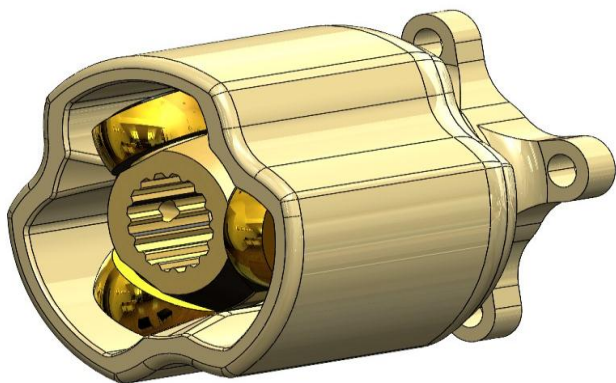

Chart-11:Tripod joint.

8.UPRIGHT

been The primary goal of our upright design was to create an optimised structure that could house the location of ball joints, brake calliper, steering point, and toe point.

2.The upright should connect the upper and lower ball joints. It must connect the components, such as the control arms, steering arms, springs, brake, and the axle at the rear. Because it is a critical component, it must withstand all forces encountered by the suspension.

3.The upright must be strong enough to withstand those forces, which may occur concurrently, such as when braking into a corner. The goal of the design is to create a light, yet

sufficiently strong upright that can withstand the forces that the new fs car will face.



Chart-12:Front upright



Chart-13:Rear upright.

Material selection is a critical design parameter when creating a part for FS competition.

The upright should be strong enough to withstand dynamic forces.

Cost, strength, and weight are important considerations for our design.

It is intended to use aluminium 7075 for the uprights to reduce unsprung mass as much as possible because its strength is comparable to steel and it is easily machined. As a result of having less weight, the vehicle's dynamic performance improves.

For the material selection of the upright, parameters are taken. Cost, Ductility, and Strength.

9.HUB

The hub should allow rotary motion to the wheel and should support the mounting of the following components.

Brake disc, Upright, the Castle Nut, Bobbins. The wheel hub must be able to withstand the forces acting on it. During a race, four major forces act on the wheel hub:

Acceleration or deceleration force, Turning a corner, Wheel movement or bump, Brake torque versus axle torque.

The main goal is to reduce the weight of the hub by changing materials such as Al Alloys grades and steel, while also increasing the load carrying capacity and strength of the hub.

Hubs made of Al7075 are preferred.

It has good fatigue strength, average machinability, and less corrosion resistance than many other Al alloys. However, its relatively high cost limits its use to applications where cheaper alloys are ineffective.

When compared to other Al alloys such as Al-6061 and Al-7075, Al6061 does not have a high strength. The 7075 aluminium alloy, on the other hand, is commonly used due to its high strength.

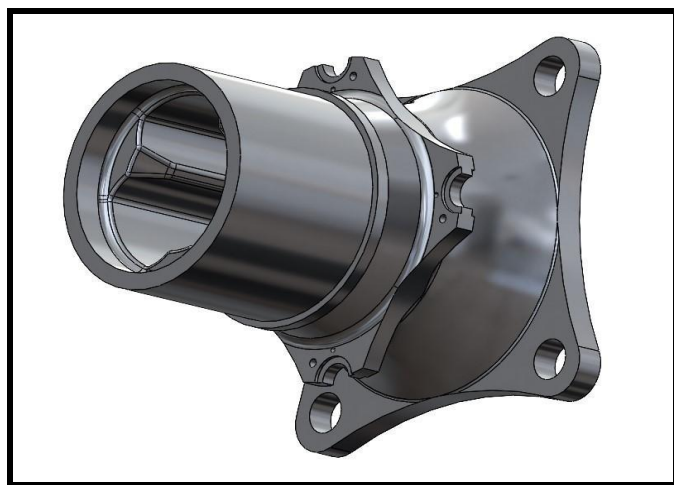

Chart-14:Rear hub

10.SIMULATIONS

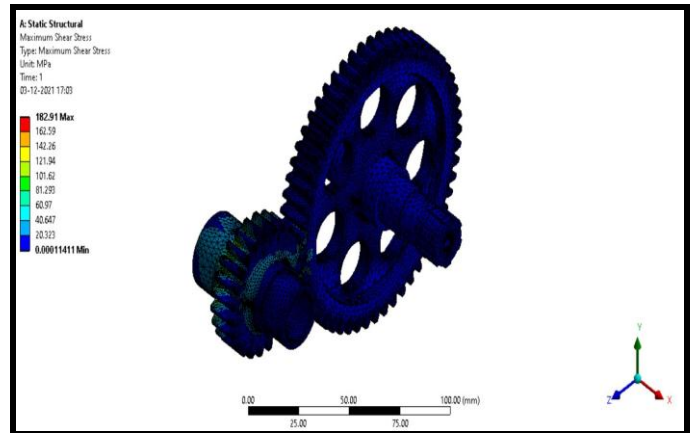

Chart-15:Shear stress of gear

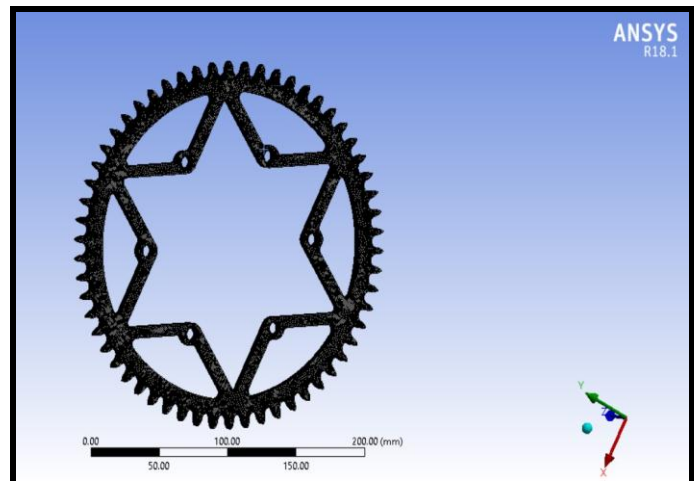

Chart-16:Meshing of Driven Sprocket

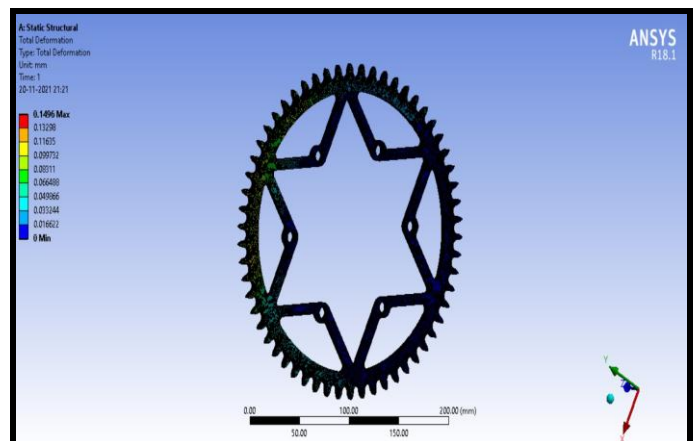

Chart-17: Total Deformation of Driven Sprocket

6.CONCLUSIONS

One of the most crucial systems is steering. Because we utilise it to steer the wheels, it is critical that the car makes an effective turn. Our main goal for this season was to lower the weight of the steering system and create a better design, which we successfully accomplished. In addition, we calculated the ideal values to facilitate pure cornering. Changing settings also resulted in less steering effort.

As seen in this report, component research, calculations, design, and analysis have been completed, and each component is the same to assemble on the drivetrain and wheel assembly.

By calculating the required torque, we design the gearbox and chain sprocket, which are used to magnify the torque. By changing the material and designing optimizations, we reduce the weight of wheel assembly components to reduce the unsprung mass. As a result o, we are able to run our vehicle with good torque and good dynamics performance.

7.REFERENCES

- [1] "International Journal of Science and Research (IJSR)." <https://www.ijsr.net/?msclkid=be983237101d1b12175b53bc64efa183> (accessed Nov. 10, 2021).
- [2] "Selection, Design & Analysis of Transmission Drives of Formula Student Vehicle Transmission System," vol. 08, no. 08, p. 5, 2021.
- [3] "IRJET-V8I7604.pdf." Accessed: Dec. 22, 2021. [Online]. Available: <https://www.irjet.net/archives/V8/i7/IRJET-V8I7604.pdf>
- [4] Claude Rouille, "Differential behavior", Optimum G lecture notes.
- [5] Milliken, William F., Milliken, Douglas L, "Race Car Vehicle Dynamics," 1985.
- [6] Carroll Smith," Tune to win," 1989.
- [7] Kloppenburg," Design of a race car differential", Thesis, University of Toronto, (2008).
- [8] "Gears- Gear Efficiency - Roy Mech." https://roymech.org/Useful_Tables/Drive/Gear_Efficiency.html (accessed Aug. 12, 2021).

BIOGRAPHIES



Pranav Khaladkar
B.E Mechanical



Sayee Deshpande
B.E Mechanical