

# HEAT TRANSFER ANALYSIS OF EFFECTS OF LONGITUDINAL FINS ON HEAT TRANSFER IN DOUBLE PIPE HEAT EXCHANGER

Abhinab Nath<sup>1</sup>, Rangina Brahma<sup>2</sup>

<sup>1</sup> UG Student, Department of Mechanical Engineering, SRM College of Science and Technology, Tamil Nadu, India

<sup>2</sup> Ph.D. Scholar, Department of Food Engineering & Technology, Central Institute of Technology Kokrajhar, Kokrajhar, BTAD, Assam:783370, India

\*\*\*

**Abstract** - Heat transfer enhancement, also known as heat transfer augmentation, refers to a variety of methods for improving heat transfer's overall effectiveness. Heat exchangers equipped with heat transfer enhancement methods are referred to as "Augmented Heat Exchangers." The primary objective is to reduce the maximum number of factors as possible be it Maintenance Cost, Power Cost, Capital Cost, Space and Weight, Consistent with increased safety and reliability. Heat transfer augmentation techniques are commonly used for cooling and heating in condensers, evaporators, thermal power plant, air-conditioning equipment, space vehicle, automobile etc. In the current paper, which deals with heat transfer analysis of double-pipe heat exchangers using longitudinal fins, the key industrial approaches are covered. Heat transfer is analyzed and its performance is found comparatively best with plain double pipe heat exchanger of same equivalent diameter pipe of internal and external. The results showed that using a longitudinal fin arrangement is beneficial for improving the LMTD's overall heat transfer and efficacy, which are shown to have increased by 28.42 watts, 12.5 watts, and 0.0322 watts correspondingly.

**Key Words:** Double Pipe Heat Exchanger, Heat Transfer analysis, Longitudinal Fins, LMTD, Heat Transfer Augmentation, Heat Transfer, Heat Exchanger

## 1. INTRODUCTION

The science of system heating and cooling is one of mechanical engineering's most essential subfields. Every time steam is needed or when hot or cold fluids are required, a heat exchanger is installed. They are installed in order to heat and cool residences, workplaces, marketplaces, retail centres, automobiles, trucks, trailers, aeroplanes, and other forms of transportation. They are employed in numerous industrial processes including in the processing of food, paper, and petroleum. They can be found in advanced computer systems, fusion power laboratories, spacecraft, and superconductors. Both in low-tech and high-tech industries, the possibilities are nearly limitless. Since the functioning of the heat exchangers has a significant impact on the process' economy and efficiency, heat exchangers have been employed in industrial processes. Therefore, high

performance heat exchangers are often desired. The size of the heat exchanger could be reduced as a result of improved performance. As an alternative, a high efficiency heat exchanger of a specific set size can enhance the heat transfer rate and/or reduce the temperature difference between the fluids, allowing for the effective utilization of thermodynamic availability. Research and development to improve heat transfer equipment design has seen tremendous growth as a result of the current imperative to preserve energy and materials.

## 2. LITERATURE REVIEW

Thomachan et al., (2016) found out that as pitch length of the fins increases with constant depth effectiveness of the heat exchanger also increases. According to the simulation of a finned double pipe heat exchanger and the findings, finned configurations exhibit generally better thermal properties than configurations without fins (Shiva Kumar et al., 2015). The annular approach achieved higher heat transfer than other ways, according to the experimental and analytical findings about the heat transfer loss and gain by hot and cold fluid (Kannan et al., 2012). Patel et al., (2013) concluded that the heat transfer rises linearly with the increase in mass flow rate for heat exchangers with and without fins. Jalay R Soni et al., (2015) concluded that the dimpled inner tubes transmit heat more quickly than the normal tubes. Monica et al., (2015) revealed that the thermal properties of rectangular finned designs are generally improved. Sreenivasalu et al., (2017) describes that at various intake temperatures and mass flow rates, the annulus side of a concentric pipe heat exchanger's characteristics of heat transfer are shown, and it is noted that the heat transfer rate and the coefficient of heat transfer, directly depend on the mass flow rates of the hot and cold fluid. Kailash et al., (2015) states that the overall coefficient of heat transfer utilising semi-circular fins reduces by more than 300% for  $Re=17161.05$ , indicating significant increases in the total heat transfer area.

### 3. SPECIFICATION

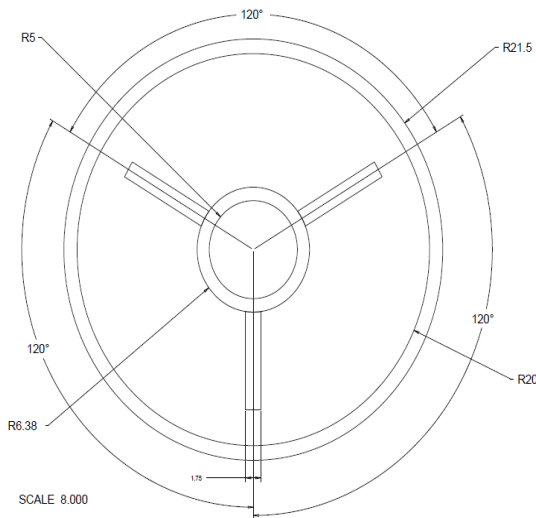

Fig 1: Cross sectional view of pipe



Fig 2: Orthographic Representation of pipe

#### The Internal Copper Pipe:

External Diameter( $d_i$ )= $\phi$ 12.7 mm

Internal Diameter( $d_o$ )=  $\phi$ 10 mm

#### The External GI pipe:

Internal Diameter( $D_i$ ) = 40 mm

diameter ( $D_o$ ) = 43mm

Outer

The length of heat exchanger =1000mm

#### Fins Specification:

Material: Copper

Number of Fins (n): 3

Length of the Fins (L):1000 mm

Height of fin (h):10mm

Thickness of fin (t):1.75mm

Angular Position Fin: 120°

#### Experimental flow drawings:

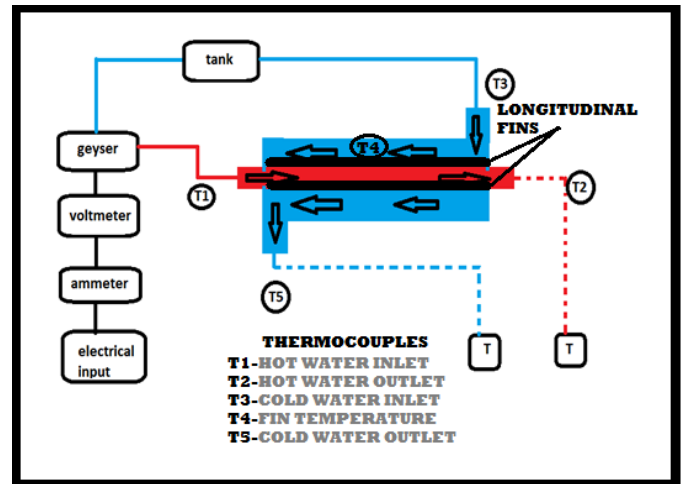

Fig 3: Experimental flow diagram

#### Thermocouple used:

Type: J

Application: It's cost-effective, precise, reliable, and has a broad temperature range.

Temperature Range: -210°C to 760°C

#### 4. EXPERIMENTAL SETUP:



Fig 4: Pictorial representation of the experimental setup

### 5. CONSTRUCTION

Through hoses and pipes, cold water is drawn from the tank. Two lines are drawn from the tank: one for the geyser input and the other for the heat exchanger's cold water inlet (T1). As a result, the heat exchanger receives cold water from the pipe above and hot water from the geyser's output. The hot water is pumped to the inlet pipe from the geyser exit (T1). The two cold water exits are linked together by a pipe. The hot water output is attached to one pipe line, much like above. A shut-off valve connects to the hot water line's input. As a result, there is a control over the water supply to the twin pipe heat exchanger. A shut-off valve connects to the cold water line's input. Therefore, set up of a parallel flow or counter flow configuration to supply cold water was made. The cold water line's intake and outflow both have thermocouples installed between them. Consequently, evaluation of the area's temperature was done. All 7 thermocouples are connected to the electric power supply and to the temperature indicator, and the geyser was connected to the electric main supply via a voltmeter and an ammeter.

### 6. OBSERVATION & FORMULA

a) Heat lost by the hot water(qh):

$$qh = mh \cdot C_{ph} \cdot (T_{hi} - T_{ho})$$

$$mh = \rho \cdot Q_h$$

$$Q_h = 1 / (1000 \times t_h)$$

b) Properties of water should be taken from bulk mean temperature (Th):

$$T_h = (T_{hi} + T_{ho}) / 2$$

c) Average heat transfer through the wall (q):

$$q = q_{conv} + q_{cond} / 2$$

d) Logarithmic mean temperature difference(LMTD):

$$LMTD = \frac{d_{Ti} - d_{Tc}}{\ln \left[ \frac{d_{Ti} - d_{To}}{d_{Ti} - d_{Tc}} \right]}$$

$$d_{Ti} = d_{Ti} - d_{Tc}$$

$$d_{To} = T_{ho} - T_{co}$$

e) Area of the heat Exchanger (Ai):  $\pi \cdot d_i \cdot p$

f) Overall heat transfer co-efficient(U):

$$U = q / (A_i \times LMTD)$$

g) Efficiency of heat exchanger(ε):

$$\epsilon = \frac{q}{C_{min}} \cdot \ln \left[ \frac{T_{hi} - T_{ci}}{T_{ho} - T_{co}} \right]$$

$$C_{min} = mh \cdot C_{ph}$$

$$C_{min} = mc \cdot C_{pc}$$

### 7. RESULT & DISCUSSION

The readings were obtained after various experimental trials and were plotted in charts. The charts are demonstrated in Fig 5 & Fig 6.

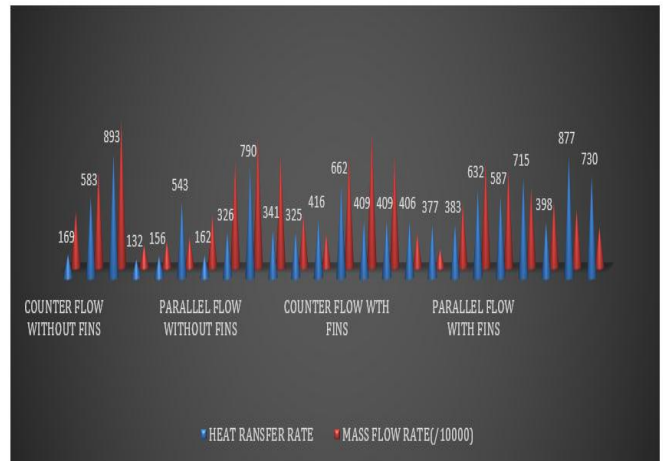

Fig 5: The rate of Heat transfer and Mass flow rate of various configurations

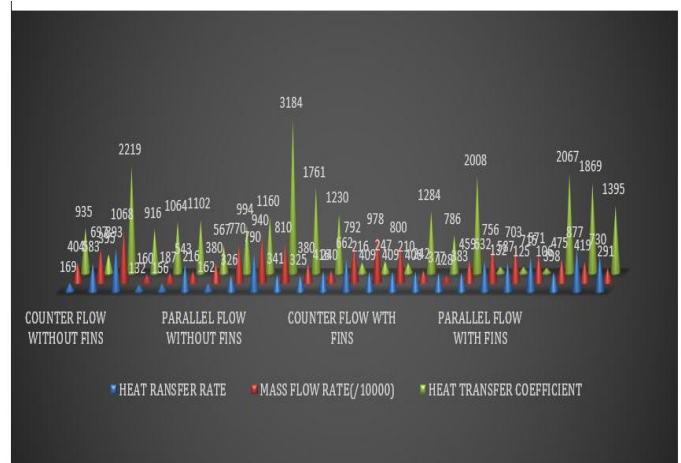

Fig 6: The Heat transfer rate, rate of mass flow and coefficient of heat transfer of various configurations

Table 1: Values of various parameters of heat exchanger with fins and without fins

S.NO.	DESCRIPTION	WITHOUT FIN	WITH FINS
1	Heat transfer rate(Q)	412.33 watts.	440.75 watts
2	LMTD	5.48°C	17.98°C
3	Cmin	66.14 W/K	191 W/K
4	Effectiveness	0.3211	0.3533

Both the parallel flow and counter flow, utilised the same fabricated double pipe heat exchanger. When compared to parallel flow heat exchangers, counter flow has an increased rate of heat transfer in both cases. It was discovered that the temperature rises at the outlet as opposed to the intake. Hence, heat is acquired from hot water. Additionally, compared to the inlet, the Reynolds and Nusselt numbers are higher near the outflow. Maximum heat transmission is achieved when Prandtl number and dynamic viscosity decrease at outflow compared to inlet. The effectiveness in parallel flow and counter flow are 0.149 and 0.320, respectively, when we use a double pipe in pipe heat exchanger. The final heat transfer coefficient (U) in parallel flow is 78.76 W/m<sup>2</sup>.K and counter flow is 176.59 W/m<sup>2</sup>.K.

## 8. CONCLUSION

This work describes the improvement of heat transmission in a twin pipe heat exchanger built of longitudinal fins in threes. The primary goal of the research was to understand how an inner tube's double pipe heat exchanger was arranged with fins fitted in a longitudinal manner. The study's findings were presented in terms of LMTD, or the rate of heat transmission. overall efficiency and effectiveness of heat transfer. Findings showed that using a longitudinal fin arrangement to improve the LMTD heat exchanger's performance is beneficial; overall heat transfer and efficacy rose by 28.42 watts, 12.5 watts, and 0.0322 watts, respectively.

## 9. FUTURE SCOPE

- a) By using the same double pipe in pipe, heat transfer augmentation for various fluids can be studied.
- b) A variety of depth to width ratio combinations can be used to study how different cross sections operate.
- c) By varying the number of fins on the inner tube, it is possible to examine how the fins' thermal augmentation works.
- d) These variant fins can be utilized for experiments on enhancing heat transfer in refrigeration systems.

## ACKNOWLEDGEMENT

The authors would like to express their thanks to the Department of Mechanical Engineering, SRM College of Science and Technology for the permission to conduct the experiments at the Department Laboratory.

## 10. REFERENCES

[1] Harshit, P., & Reena, N. (2013). Performance evaluation and CFD analysis of industrial double pipe heat exchanger. *International Journal of Emerging Trends in Engineering and Development*, 4(3).

[2] Indhe, M. J., & Bhatkar, V. W. (2015). Optimization of longitudinal fin profile for double pipe heat exchanger. *International Research Journal of Engineering and Technology*, 2(4), 517-529.

[3] Karanth, V. K., & Murthy, K. (2015). Numerical study of heat transfer in a finned double pipe heat exchanger. *World Journal of Modelling and Simulation*, 11(1), 43-54.

[4] M.Kannan, S.Ramu, S.Santhanakrishnan, G.Arunkumar, Vivek.M, Experimental And Analytical Comparison Of Heat Transfer In Double Pipe Heat Exchanger, 2012 *International Journal of Mechanical Engineering applications Research – IJMEAR*, ISSN: 2249- 6564, Vol 03, Issue 03; July.

[5] Nice Thomachan, Anoop.K.S , Deepak.C.S , Eldhose.P.Kuriakose, Habeeb Rahman.K.K, Karthik.K.V, CFD analysis of tube in tube heat exchanger with fins, *International Research Journal Of Engineering And Technology (IRJET)* E-ISSN: 2395 -0056, Volume: 03 Issue: 04 | Apr-2016 www.irjet.net P-ISSN: 2395-0072.

[6] Ojha Pramod Kailash, Choudhary Bishwajeet NK, Gajera Umang B, Prajapat Sumit B, Karangiya Gopal A, (2015). Design and experimental analysis of pipe in pipe heat exchanger, *International Journal of Modern Engineering Research (IJMER)*, ISSN: 2249-6645 Volume 5, Issue: 3, pp. 42-48.

[7] Reddy, N. S., Rajagopal, K., & Veena, P. H. (2017). Experimental investigation of heat transfer enhancement of a double pipe heat exchanger with helical fins in the annulus side. *International Journal of Dynamics of Fluids*, 13(2), 285-293.

[8] Soni, J. R., & Khunt, J. B. (2015). CFD analysis and performance evaluation of Concentric Tube in Tube Heat Exchanger. *International Journal, for Innovative Research*, 2(1), 18-21.