

GREENHOUSE MONITORING AND AUTOMATION SYSTEM

Monisha S R¹, Varadraj D Yalamalli², Syed Numan U S³, Harshith Gowda K R⁴, Rakesh M D⁵

^{1,2,3,4}Students, Department of Electronics and Communication Engineering, JSS Science and Technology University, Mysuru, India

⁵Assistant Professor, Department of Electronics and Communication Engineering, JSS Science and Technology University, Mysuru, India

Abstract - Agriculture in India is still carried out in conventional ways and lags behind in integrating modern technologies. Around 55 percent of the Indian population has been engaged in agriculture and allied activities which constitute only 15 percent of GDP so it becomes much important for the stakeholders involved to come out of the conventional agricultural practices and modernize the agriculture using technology. This project is primarily about the improvement of current agricultural practices by using modern technologies for better yield. This work provides a model of a smart greenhouse using IOT, which uses Node MCU for communication and the Blynk as the server. The android application developed shows the values of various parameters like temperature, soil moisture and also can control the automation system with the help of user-friendly UI. It can not only control one greenhouse but can also control a number of greenhouses using a single app. This project helps the farmers to carry out the work in a farm automatically without the use of much manual inspection.

Key Words: Smart greenhouse, IOT, Node MCU, Blynk, android application

1. INTRODUCTION

Agriculture is an important part of India's economy and at present it is among the top two farm producers in the world i.e., India ranks second worldwide in farm outputs. This sector provides approximately 52% of the total number of jobs available in India. Agriculture is the only means of living for almost two-thirds of the employed class in India. The agriculture sector of India has occupied almost 43% of India's geographical area. Indian agriculture has registered impressive growth over last few decades.

In modern society, the consumption of fruits and vegetables has become the norm. A variety of fresh fruits and vegetables should be accessible at all times. However, the northern climate prevents the growth of certain fruits and vegetables, especially during winter. This results in import from southern countries, which in turn has some drawbacks. Not only does the shipping of imported goods affect the environment negatively but imported food or vegetables are also less flavourful and sold at a higher price. The crops must be harvested prematurely when importing food. This is to delay the ripening process so that it is possible for the

fruits or vegetables to reach their destination before they are considered inedible.

The ripening process is later resumed by spraying the food with ethylene gas, a gas that is deemed to promote ripening in certain fruits and vegetables. However, this post harvest ripening can lead to poor taste. In the past couple of years, an increased interest in organic and locally produced food has become a growing trend. Locally grown foods are picked at their peak of ripeness and are therefore full of flavour. Furthermore, growing food at home assures truly organic food. On the other hand, it takes a lot of time and effort, and time is something that most people lack today.

The purpose of a greenhouse is to control the growing environment. Plants require a limited range of temperature, soil moisture, light, humidity, air (Oxygen, Carbon Dioxide and Nitrogen), and nutrients to grow. Plants also require some type of physical support for roots and shoots. Plants also depend upon symbiotic relationships with fungi and insects to grow and reproduce. The greenhouse covering helps to control many of these factors to help increase plant growth and reproduction.

1.1 MOTIVATION

Monitoring the climatic parameters like humidity, soil moisture, illumination, soil pH, temperature etc. directly or indirectly govern the plant growth. There are some places which receive ample amounts of water through river and canal irrigation systems, face problems of soil salinity due to excess irrigation. Similarly, few other places face the problem of acute water shortage for agriculture. Different plants require different amounts of moisture, humidity, temperature etc. and lack of awareness of this information or negligence of a person cultivating land can cause plants to die before maturing. Thus, an automated system is necessary for the monitoring of plants.

1.2 PROBLEM STATEMENT

Cultivating various crops in environmental conditions which do not support their growth is a challenging task today. One must keep keen vigilance on the growth and development at regular intervals. If there are any sudden climatic changes, then the crops get adversely affected. The required amount of temperature, soil moisture, light, humidity, air (Oxygen,

Carbon Dioxide and Nitrogen), and nutrients to be provided for the plants is to be monitored properly for better yield. Thus, in order to grow plants properly and provide necessary environmental conditions, greenhouse monitoring and automation system is needed.

1.4. OBJECTIVES

1. The main objective of this greenhouse automation system is to increase the yield with the help of automation.
2. To benefit farmers by automating the growth of plants and reducing their direct supervision.
3. To develop a system that can monitor various plants in multiple greenhouses remotely.
4. To develop user interface where user can choose particular crop, set values for different parameters or load data

2. LITERATURE SURVEY

Recent developments in this sector have seen the rise and rapid growth of revolutionary and disruptive technologies. Here are a few research papers and works which deal with the greenhouse monitoring project. In the paper [1], the greenhouse monitoring system was designed to satisfy the need for remote monitoring and control of the greenhouse. This system is made up of front-end data acquisition, data processing, data transmission and data reception. It is an IOT system based on B/S structure which uses CC2530 as the core processing chip. ZigBee technology is adopted in wireless communication.

In the paper [2], the proposed IOT architecture does not only enable the autonomous control of the greenhouse operational conditions but also allows the owner to remotely control the greenhouse through the Internet. The owner can also monitor and keep record of the progress throughout the plantation period of the crops inside the greenhouse with the help of switched Ethernet and WiFi.s.

The paper [3] proposes an embedded system which comprises sensors, ADC, PIC 16f877a microcontroller and actuators. When any of the climatic parameters cross a safety threshold, the sensors sense the change and the microcontroller reads this from the data at its input ports and displays on LCD.

The paper [4] is proposed for long-term space missions to grow vegetables and fruits inside the spacecraft or in specific living modules. The WSN in this project is composed of autonomous flexible and polymeric nodes equipped with humidity, temperature, illuminance sensors together with nano structured flexible devices devoted to the detection of gasses such as CO₂, NO_x, etc.

In the paper [5] the greenhouse controls different parameters, such as humidity, water nutrients solution level, pH and electrical conductivity value, temperature, UV light intensity, CO₂ level, mist, and amount of insecticides or pesticides, are monitored through various sensors so that significant knowledge would be captured and early fault detection and diagnosis can be done. A decision support system (DSS) acts as the central operating system that governs and coordinates all the activities.

The paper [6] is about greenhouses which are climate-controlled structures with walls and roof specially designed for offseason growing of plants. The sensors used here are YL69 moisture sensor and DHT11. From the data received, Raspberry PI3 automatically controls various parameters efficiently by actuating respective actuators. The recorded values are stored in a cloud database and the results are displayed in a webpage.

The paper [7] is proposed to implement a smart farm system using low power Bluetooth and Low Power Wide Area Networks (LPWAN) communication modules including the wired communication network used in the existing farm. The system also implements the monitoring and control functions using the MQ Telemetry Transport (MQTT) communication method, thereby enhancing the possibility of development of agricultural IoT.

In the paper [8], the author made reference to the concept of architecture of Internet of Things (IoT) to design a complete remote monitoring system on the basis of Agricultural IoT and to improve energy efficiency, reliability, safety and customer experience. Low-cost single chip machine series STM32F103 will be adopted for network transmission layer to form complete gateway equipment.

The paper [9] designs a greenhouse monitoring system based on ZigBee and GPRS. The system is integrated with wireless sensor network technology and GPRS technology for data collection, wireless transmission, remote communication and monitoring. The system uses GPRS technology to send data to the Internet, and using Visual Studio software realize human-computer interaction interface with ASPNET,

In paper [10], a WSN was implemented by deployed wireless sensor nodes in a greenhouse with sensors. The proposed system has a sensor node to read the different parameters and control a device with respective sensors. Wi-Fi and GSM technology is used for communication between the sensor node and the gateway based on distance. A GUI panel is designed using LabView to monitor and control the sensor node components and devices

3. PROPOSED SYSTEM

3.1. Block Diagram

The proposed greenhouse monitoring and automation system can be modeled as shown in the fig 1. It shows how various components of the system are connected with one another.

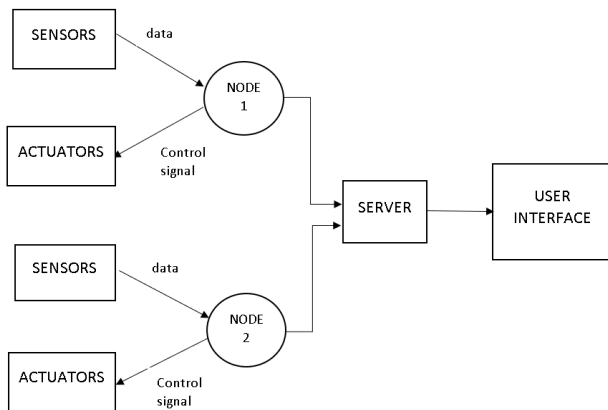

Fig-1: Block diagram

The data from the sensor is retrieved and is then sent to the server where the data is filtered and converted to user readable form and then sent to the android application (UI) and can also report the user if it is unable to maintain conditions and to check for errors. According to the crop selected, the data which needs to be maintained is checked after certain intervals of time. The automation system has various sensors for monitoring temperature, humidity and soil moisture. The sensors continuously collect the data from the greenhouse and transmit it to the control unit. The control unit checks for the data received, and if the data is greater / lesser than the threshold value set based on the requirement, it sends signals to actuators to perform specific tasks. The actuating part includes turning on the cooling fan, motor etc. The proposed system not only controls one greenhouse but can control a number of greenhouses with the help of the server. Different greenhouses can be set to different crops for their growth. A user interface will be provided where one can set values of different parameters for different crops, change the crop and can also perform various manual operations.

3.2. Hardware Requirements

1. Node MCU - ESP8266:

It is a self-contained SOC with integrated TCP/IP protocol stack that can give any microcontroller access to the WiFi network. In this project, ESP8266 is used to collect information from the sensors and send it to the server.

2. Soil moisture sensor:

Soil Moisture Sensor is used for measuring the moisture in soil. It has two large exposed pads which function as probes for the sensor, together acting as a variable resistor.

3. DHT22 sensor:

It is the temperature and humidity sensor. This helps the farmer to know about the temperature and humidity in the atmosphere and plan the watering of plants accordingly.

4. PIR sensor:

The PIR Motion sensor measures the distance based on the heat radiations (passive IR radiations). It helps to detect intruders in the greenhouse zone.

5. Relay:

A relay is an electrically operated switch. Here, the SPDT relay is used to on/off the pump

3.3. Software requirements

1. Blynk:

Blynk is an open-source platform to develop easy the mobile phone application. This can connect electronic devices to the Internet and remotely monitor and control these devices.

2. Arduino IDE:

The Arduino IDE is a cross platform Java application that serves as a code editor and compiler and is also capable of transferring firmware serially to the board.

4. IMPLEMENTATION

4.1. Hardware Implementation

The green house is built using gate sheet which absorbs the input solar radiations and does not let it escape the house which provides good warmth inside the greenhouse. The various sensors and the respective actuators are placed inside the greenhouse. The flow of working is shown in figure 2.

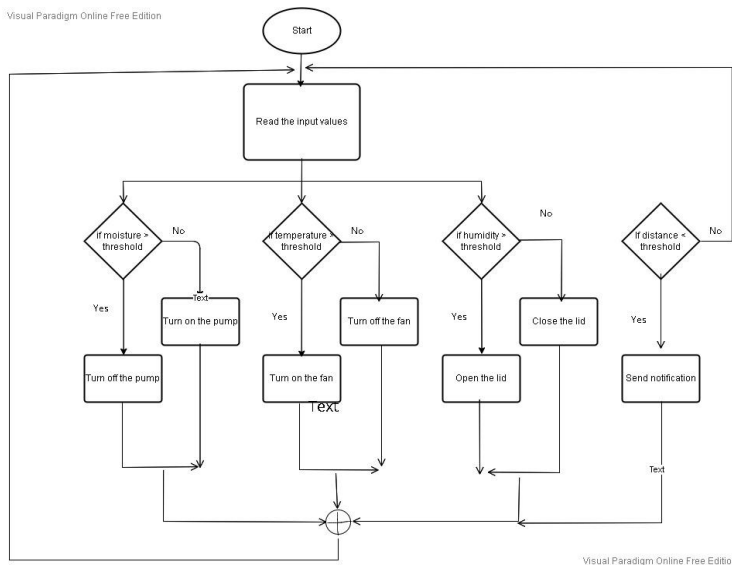

Fig-2: Flow chart

The temperature and humidity sensor is placed in the green house to measure the temperature. The cooling fan is associated with this i.e., the sensor reads the input and compares the value with the threshold value of the temperature. If it is greater than the threshold, then it sends the signal through relay module to turn the cooling fan on. The temperature and humidity sensor sensor is placed in the green house to measure the humidity. The servo motor is associated with it to simulate the opening and closing of the window i.e., the sensor reads the input and compares the value with the threshold value of the humidity. If it is greater than the threshold, then it sends the signal through relay module to turn the servo motor on. The Soil Moisture sensor is placed in the soil to measure the moisture level of the soil. The servo motor is associated with it to simulate the opening and closing of the window i.e., the sensor reads the input and compares the value with the threshold value of the humidity. If it is greater than the threshold, then it sends the signal through relay module to turn the servo motor on. The PIR sensor senses the heat radiations the as animals and human beings emit more heat when compared to plants so it is used for intruder detection and notifies the end user. The sensor reads the input and compares the value with the threshold value of the radiations. If it is greater than the threshold, then it sends the signal through the server and server sends the notification to the user.

4.2. Hardware Communicating with Server

The diagram shown in fig 3 shows the communication of hardware with the server. It overlooks the applications running on hardware device and explains the way in which

the application communicates with or access the resources (database) contained in blynk cloud server and also how the server interfaces with applications being executed on hardware device. The diagram shown in figure 3.10 gives a rough idea about the structure of Hardware application and the way in which it communicates with applications running on server interface (that is read and write the database).

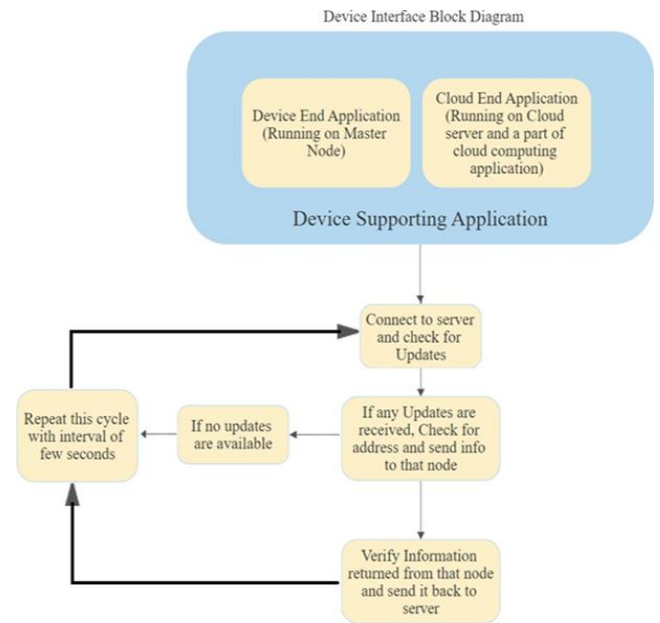

Fig-3: Hardware communicating with server

The diagram demonstrates how the hardware applications require to use or access the database. It will request the server to verify input data from the device by comparing it with pre-loaded data in the user database or to send back the device gpio status in that particular database, but still access it will be granted by the main application. Only if access is granted by the main application to the sub application, that particular application can read or write to database. This has to be designed this way so as to avoid overwriting of databases by different files and also to avoid write rejection by database because that can be in an un-closed state if opened by any other application at the same time.

4.3. Software Implementation

The diagram below is to explain the structure of the code, though the below representation is not the algorithm or the flow chart of the code running on ESP-2866 but it will definitely help understand the logic of our code. The structure of the code is shown in figure 3.

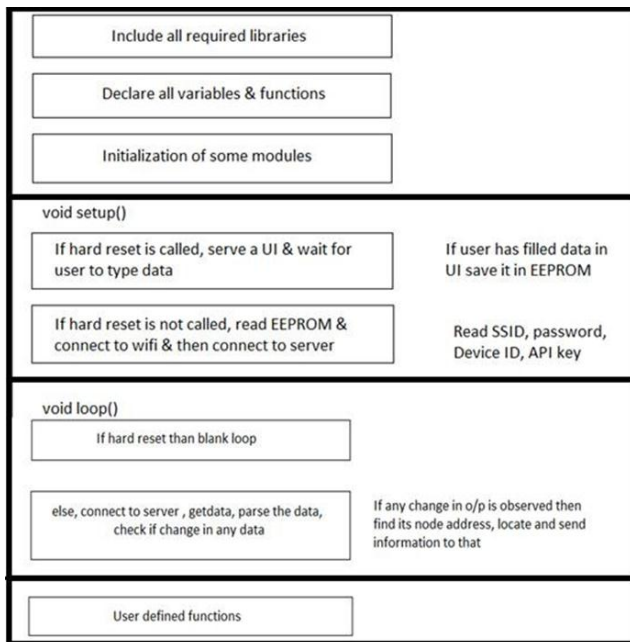

Fig-3: Structure of the code

The Library files such as servo.h, ESP8266WiFi.h, BlynkSimpleEsp8266.h, DHT.h the mentioned library files are servo.h is used to control a great number of servos. It makes careful use of timers: the library can control 12 servos using only 1 timer. ESP8266WiFi.h is used to connect your new ESP8266 module to a Wi-Fi network to start sending and receiving data. BlynkSimpleEsp8266.h is used to configure out node mcu with the Blynk platform. In the setup part, we give the ssid and the password to connect with the wifi as the ESP2866 has in built http module which has GET and POST. Here, GET is used to request data from the specified resource and POST is used to send data to a server to create/update a resource. The authentication key and password are then initialized to access the server to send/receive data across the server. Also during the setup part the pins are defined for input and output and named accordingly. In the loop part of the code if the connection is alive then the functions are carried out to read the sensor The input data is simultaneously sent to the server through Blynk the input is then compared the with the threshold values and the values to the actuators is written accordingly else the node MCU tries to reconnect to server and check for the data changes and perform specific actions

4. RESULTS

The greenhouses were built and the seeds were sown in the greenhouse. Tomato plant was selected for the demonstration. The figures 4 and 5 shows the growth stages of tomato plant.

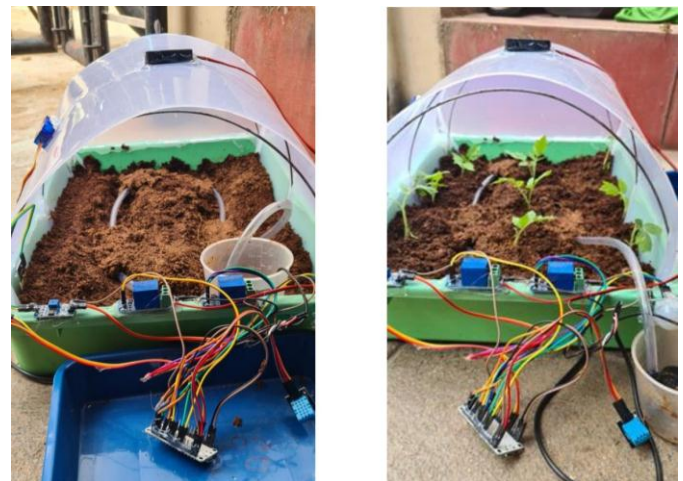

Fig-4: Day 1 and day 15 of tomato plant



Fig-5: Day 30 of tomato plant

The tomato plant requires the specific conditions for its growth which is shown in table 1.

Table-1: Specifications required for tomato plant

Temperature	19 to 29.5 degree celcius
Humidity	70 %
Soil Moisture	70 - 80% - max (307.2) 40% - min (614.4)

The table 2 shows the recordings taken upto 30 days of tomato plant with different parameters. The readings were taken from the day the seeds were sown.

Tabel-2: Recordings of various parameters of tomato plant

Date	Temperature	Humidity	Soil Moisture
2022/05/20	30	79	464
2022/05/21	28	80	439
2022/05/22	25	76	581
2022/05/23	25	77	435
2022/05/24	27	76	454
2022/05/25	25	79	569
2022/05/26	28	76	613
2022/05/27	25	78	510
2022/05/28	30	76	481
2022/05/29	30	78	530
2022/05/30	27	79	586
2022/05/31	29	80	583
2022/06/01	27	80	546
2022/06/02	30	76	592
2022/06/03	28	75	444
2022/06/04	29	78	498
2022/06/05	27	79	490
2022/06/06	30	77	526
2022/06/07	30	80	568
2022/06/08	29	79	568
2022/06/09	27	77	435
2022/06/10	26	75	590
2022/06/11	28	77	556
2022/06/12	27	79	423
2022/06/13	29	79	537
2022/06/14	29	78	464
2022/06/15	29	75	423
2022/06/16	27	77	547
2022/06/17	25	76	500
2022/06/18	27	77	507

The android application was developed for the greenhouse monitoring and automation which is shown in the figure 6. It shows the humidity, temperature, soil moisture and the intruder alert. It also allows the user to set the values of the threshold variables for different crops manually.

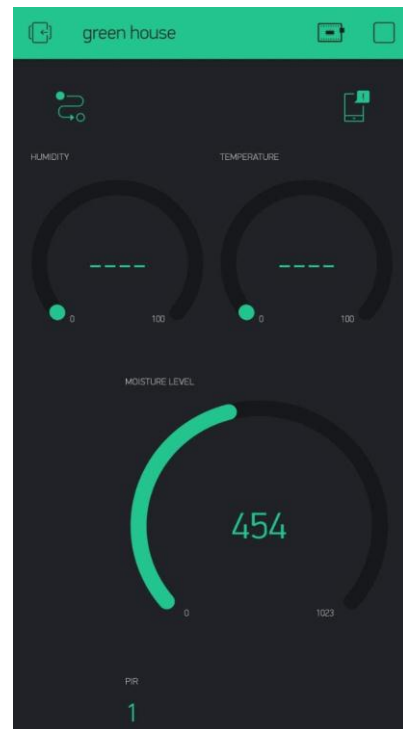

Fig-6: The UI of the app

5. CONCLUSION

Agriculture is seeing an increased need for application of automation, computers and controls. There is also a real need for engineering students to understand, specify and design computer-controlled equipment. The system may be programmed remotely over the internet and immediate results of program / parameter changes may be seen almost instantaneously. A control system was designed and programmed to control and acquire data. The prototype of the system worked according to the specifications and quite satisfactorily.

The developed system is suitable for both large scale agribusiness as well as small agriculture farm. The system helps to eliminate the stress of manual labour. It eliminates risk of human errors to maintain a greenhouse at a specific environmental condition.

REFERENCES

[1] L. Dan, C. Xin, H. Chongwei, and J. Liangliang, "Intelligent agriculture greenhouse environment monitoring system based on IOT technology," in 2015 International Conference on Intelligent Transportation, Big Data and Smart City, 2015, pp. 487-490.

[2] H. Ibrahim et al., "A layered IoT architecture for greenhouse monitoring and remote control," SN Appl. Sci., vol. 1, no. 3, 2019.

- [3] Sivagami, A., Hareeshvare, U., Maheshwar, S., Venkatachalapathy, V. S. K. (2018). Automated irrigation system for greenhouse monitoring. *Journal of The Institution of Engineers (India) Series A*, 99(2), 183–191.
- [4] D. Polese, L. Maiolo, L. Pazzini, G. Fortunato, A. Mattocchia, and P. G. Medaglia, “Wireless sensor networks and flexible electronics as innovative solution for smart greenhouse monitoring in long-term space missions,” in 2019 IEEE 5th International.
- [5] Workshop on Metrology for AeroSpace (MetroAeroSpace), 2019, pp. 223–227.
- [6] P. K. Tripathy, A. K. Tripathy, A. Agarwal, and S. P. Mohanty, “MyGreen: An IoT-enabled smart greenhouse for sustainable agriculture,” *IEEE consum. electron. mag.*, vol. 10, no. 4, pp. 57–62, 2021.
- [7] M. Danita, B. Mathew, N. Shereen, N. Sharon, and J. J. Paul, “IoT based automated greenhouse monitoring system,” in 2018 Second International Conference on Intelligent Computing and Control Systems (ICICCS), 2018, pp. 1933–1937.
- [8] C. Yoon, M. Huh, S.-G. Kang, J. Park, and C. Lee, “Implement smart farm with IoT technology,” in 2018 20th International Conference on Advanced Communication Technology (ICACT), 2018, pp. 1–2.
- [9] C. Changqing, L. Hui, and H. Wenjun, “Internet of agriculture-based low-cost smart greenhouse remote monitor system,” in 2018 Chinese Automation Congress (CAC), 2018, pp. 3940–3945.
- [10] L. Liu and W. Jiang, “Design of vegetable greenhouse monitoring system based on ZigBee and GPRS,” in 2018 4th International Conference on Control, Automation and Robotics (ICCAR), 2018, pp. 336–339.