

IOT BASED ELECTRICAL MOTOR CONTROL AND MONITORING

T B DAYANANDA¹, MANJUNATH N², THARUN M T³, VEERABHADRASWAMY R⁴, YASHWANTH KUMAR V M⁵.

¹Associate professor, Department of EEE, Dr. AIT, Bengaluru Karnataka-560056,India

^{2,3,4,5} Students, Department of EEE, Dr. AIT, Bengaluru Karnataka-560056,India

ABSTRACT: At present, industries are rapidly shifting towards automation. Today's industrial automations mostly based on programmable controllers and robots. In order to do the tedious work and to serve the mankind, automation is developed in industries. DC motor plays an important role in various industries hence we selected it. This project present a system to provide protection, control and monitoring the condition of DC motor. Here Arduino Uno and various sensors like current, voltage, speed and temperature sensors are used. Real time values of various parameters like current, voltage, temperature and speed can be monitored in ThingSpeak mobile app. By continuous monitoring, the motor can be protected against fault like short circuits, overloading, overheating etc. hence machine performance is improved.

Keywords: IoT, Arduino Uno, Node MCU, DC motor, LCD, Fault, etc.

1. INTRODUCTION

Nowadays there is advancement in technologies, in order to reduce the man power in industries, the industries are shifted towards automation. DC motors are used in various industries because of their small size and high energy output. The manual control of motor in different areas of an industry for the switch ON or OFF is time consuming and inconvenient here an effort is made to control automatically. Protection or maintenance is also very important aspect for the smooth operation of motor in an industry. The monitoring of several Parameters of motor like voltage, current, temperature and speed etc. by human is very time consuming process. These problems are studied and developed a remote project as solution called IOT BASED ELECTRICAL MOTOR CONTROL AND MONITORING. In this paper, a cost effective protection and control system has been developed for DC motors which can be used in practice.

1.1 Motor Protection Scheme

In the motor protection scheme, the respective sensors provide accurate and precision intimation So as to protect the motor under abnormal condition like protection against overheating, over current and voltage fluctuations.

1.2 Motor Monitoring Scheme

Real time values of several parameters like voltage, current, temperature and speed are sensed by sensors and uploaded to the ThingSpeak application using Node MCU which gives us feature of real time monitoring of motor from mobile device. The values are compared with default values to determine the condition of the motor.

2. METHODOLOGY

In this project, we have interfaced various sensors with the Arduino Uno, Node MCU and the motor to collect data of the various parameters like voltage, current, temperature and speed to know the condition of the motor and also give protection against over voltage, under voltage, over load and thermal overloading by providing program for that, so if the motor crosses the predefined value of current, voltage and temperature by some fault it will get automatically turn off and the alarm gives signal on the application. Also we can turn on/ off motor by button placed in the application. Block diagram, and results are discussed below.

2.1 Block Diagram

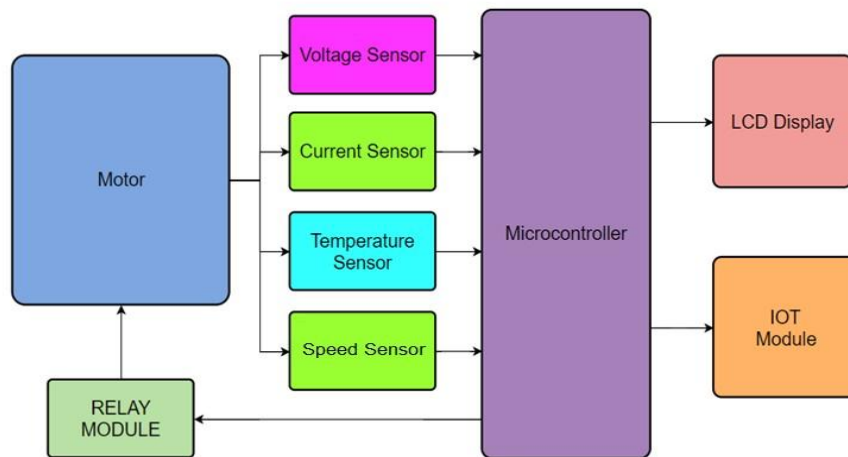

Fig 1: Block diagram

In this project work, the voltage sensor is used to read the voltage value. The current sensor is used to read the current value, temperature sensor is used to measure the temperature of the DC motor. The speed sensor is used to monitor the speed of the motor. The signal from the above mentioned sensors is processed by the Arduino uno with the predefined values. The Node MCU is used to transmit the real time data to an application for remote monitoring. If the values of any parameters of the DC motor is not within the predefined value then specific abnormality will be triggered and the motor will shut down automatically. LCD display is used to display the parameters of the motor on the spot and using Node MCU the abnormality condition is notified to the linked mobile devices.

2.2 Remote Monitoring

Remote monitoring is done using Node MCU which has inbuilt Wi-Fi. Which is interfaced with Arduino Uno for sensor data which can be used to link to ThingsSpeak mobile application. By this way real time monitoring can be achieved.

3. HARDWARE MODEL

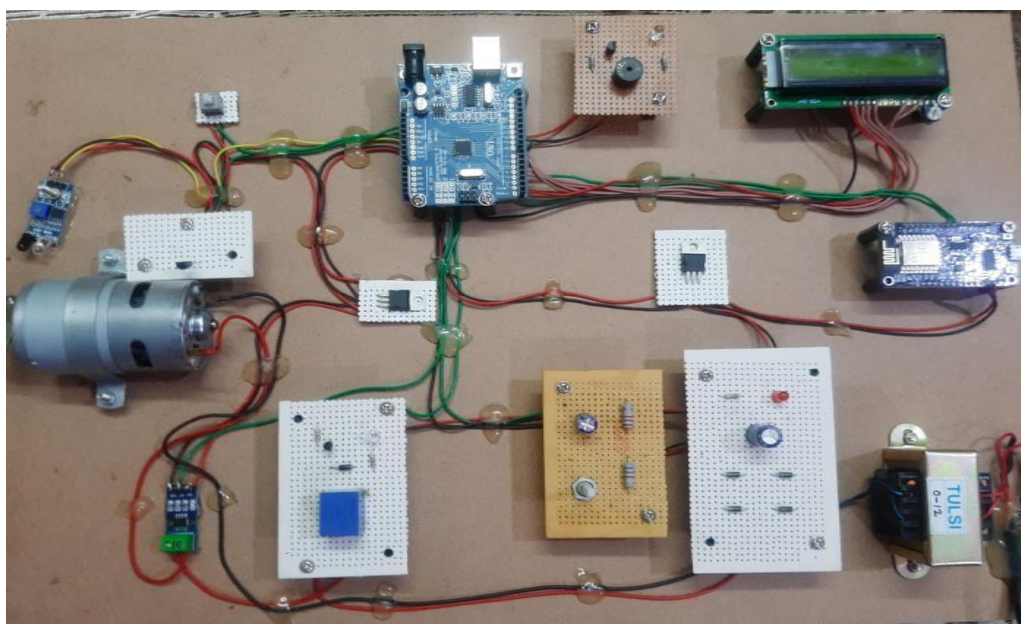

Fig 2: Hardware Model

4. RESULTS

In this project the predefined values of various parameters were, if current exceeds 1900mA then over load condition is triggered, if voltage exceeds 14V then over voltage condition is triggered, if voltage goes below 11V then under voltage condition is triggered, if temperature exceeds 35°C then thermal overload condition is triggered. Speed sensor is used to monitor the speed of the motor. In all these cases the alarm is triggered the condition of motor is displayed using LCD display. And the parameters of the motor are also monitored using mobile application.

5. SIMULATION

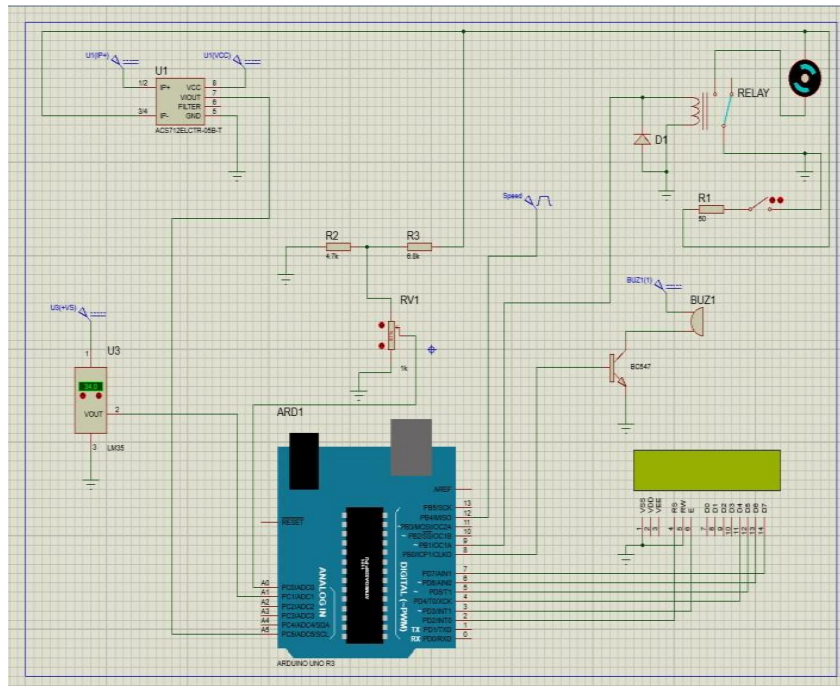

Fig 3: Simulation Setup in Proteus

This is the simulation setup we have done in the Proteus software. And we have set the predefined values to

- 1 Above 35 C thermal overload fault.
- 2 Above 12V overvoltage fault.
- 3 Below 9V under voltage fault.
- 4 Above 400mA overload fault

6. SIMULATION RESULTS

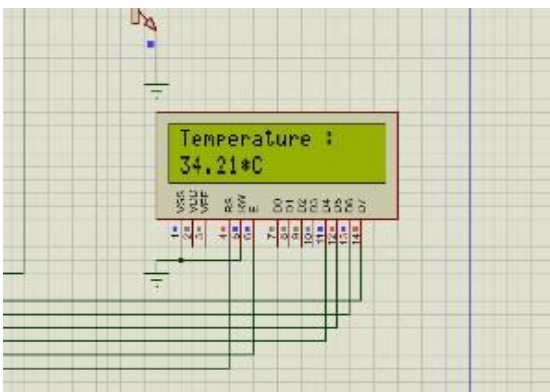

Fig 4: Temperature reading is displayed

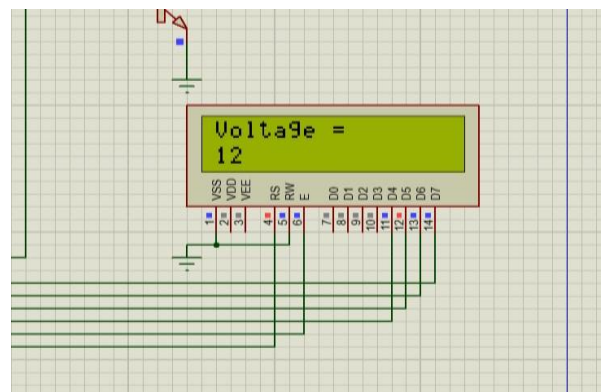

Fig 5: Voltage reading is displayed

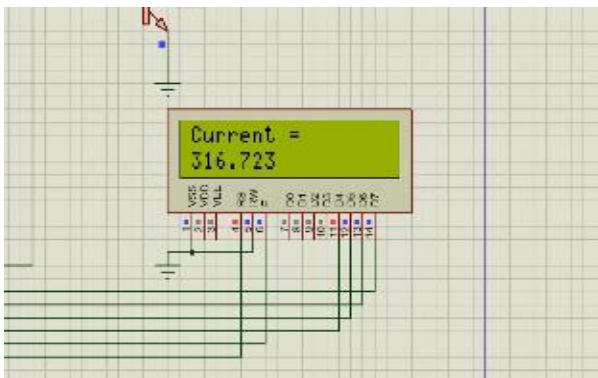

Fig 6: Current reading is displayed

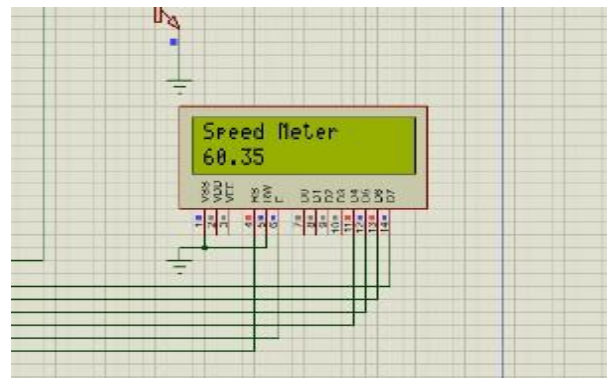

Fig 7: Speed (RPM) reading is displayed

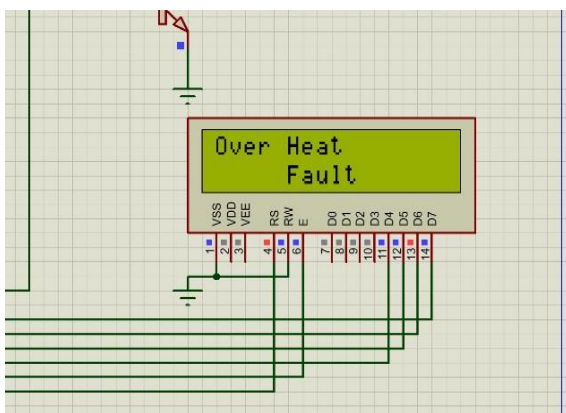

Fig 8: Over heat fault is displayed

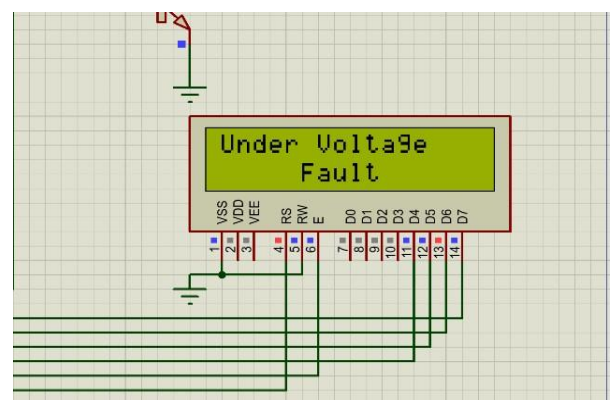

Fig 9: Under voltage fault is displayed

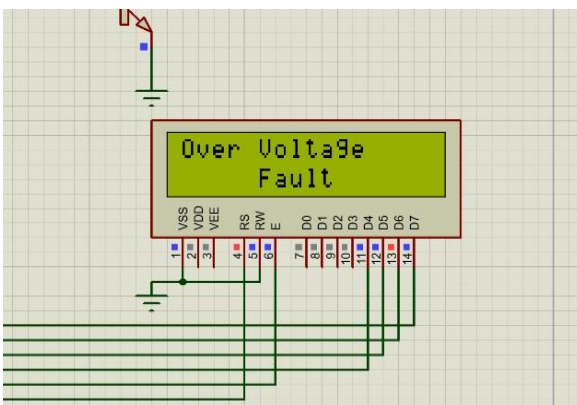

Fig 10: Over voltage fault is displayed

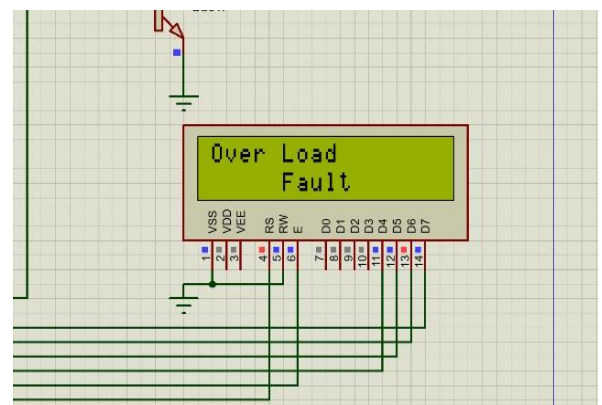

Fig 11: Over load fault is displayed

7. IOT NOTIFICATION TO SMARTPHONE

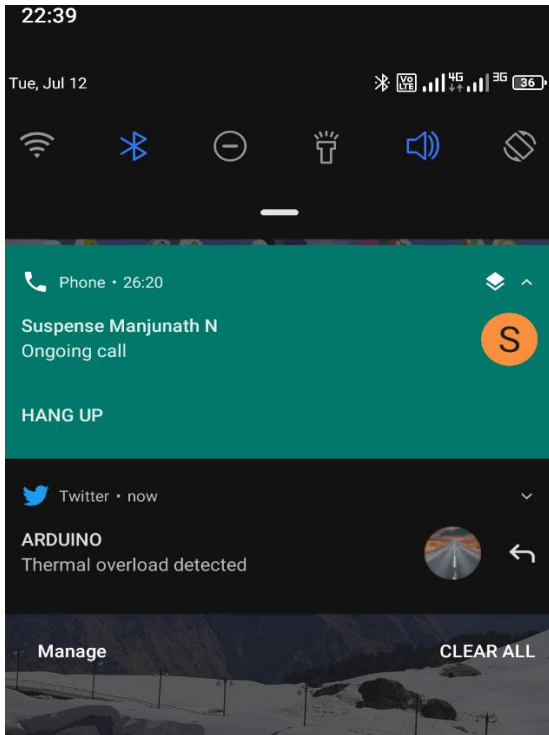

Fig 12: Over heat fault is notified

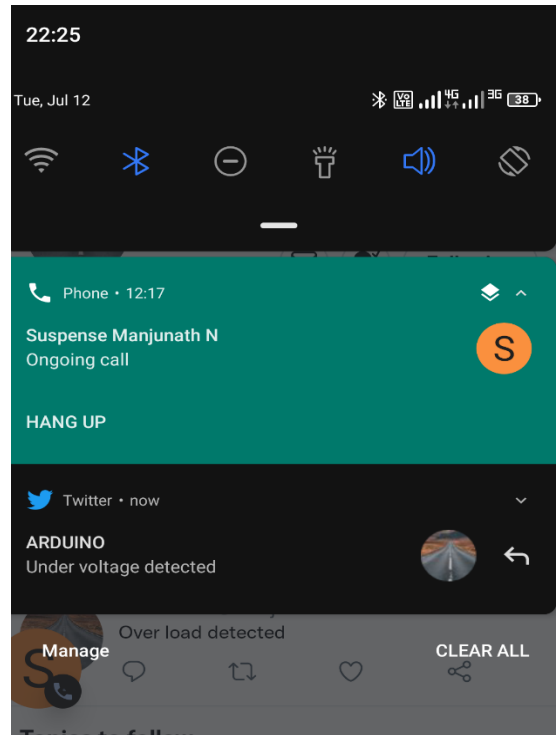

Fig 13: Under voltage fault is notified

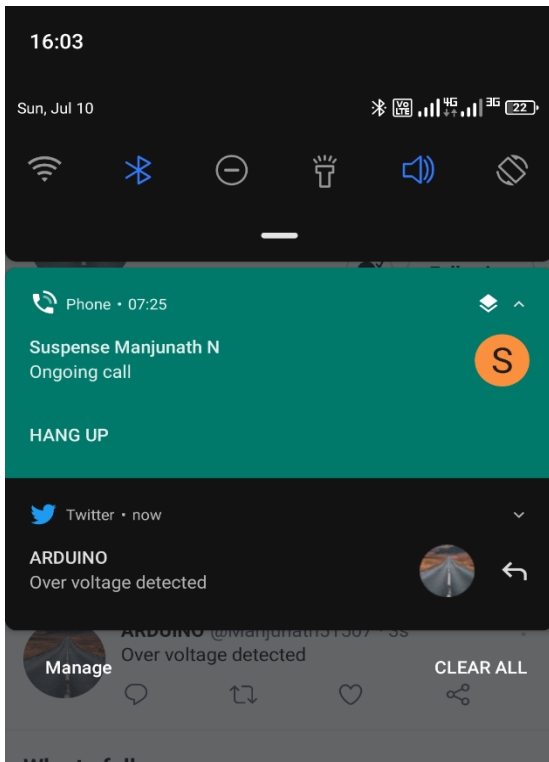

Fig 14: Over voltage fault is notified

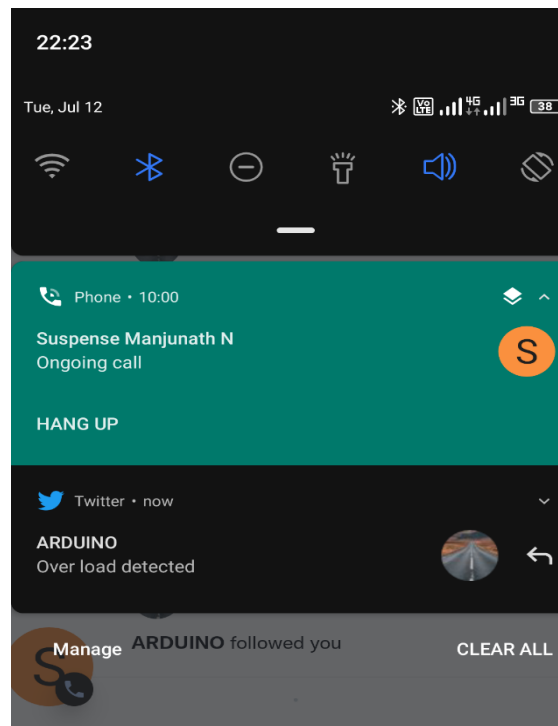

Fig 15: Over load fault is notified

8. CONCLUSION

In this project, a system introduced that can protect, control and monitor a DC motor through mobile application using Arduino Uno and Node MCU. Various parameters like current, voltage temperature and speed and their real-time values can observed on the screen. Protection against the overload, overvoltage, under voltage and overheating is achieved. Also we have successfully completed simulation part of this project.

9. REFERENCES

[1] S.U.PRABHA, S.PAVITHRA, International Research Journal of Engineering and Technology (IRJET) e-ISSN: 2395- 0056 Volume: 07 Issue: 03, April-2020.

[2] JYOTHI B GADADE, BE. Student Dept. of Electrical Eng., S. B Patil college of engineering, Maharashtra, India, (IRJET-V5I5666) eISSN:2395-0056, May-2018.

[3] PREETHI. R, DHIVYA. N, Knowledge institute of technology, Kakapalayam, Salem, (IRJET- V2I6189) e-ISSN:2395-0056, September-2015.