

1MWH SOLAR PLANT CONNECTED TO MICROGRID WITH BESS CONTROLLER

Akansha Bhargava¹, Prof. Ashish Duvey²

¹ Research Scholar, Dept of Digital Communication Shri Ram College of Management and Technology Digital communication

² Assistant professor, Dept of Digital Communication Shri Ram College of Management and Technology Digital communication

Abstract - Despite the rapid growth of the photovoltaic (PV) industry, most of the energy demand in the India is supplied by fossil fuel power plants. One of the main reasons for this is that PV is non-dispatchable, meaning it is limited to times when the sun is shining. Because of this, utilities must maintain reliable grid infrastructure for times when PV is not available but there is still demand, such as in the evening when the sun has gone down but the electricity demand is greatest. This leads to electricity infrastructure going unutilized much of the time, wasting valuable resources while fossil fuel power plants are still harming the environment. The non-dispatchable nature of PV limits the amount of PV that can be connected to the grid. One remedy for this limit is to add energy storage to PV systems, or to shift deferrable loads from times of peak electricity demand to times when the sun is shining. With storage, batteries can be charged when the sun is shining, and discharged when the electricity demand is highest. Energy storage and load shifting allow more loads to be met locally rather than importing energy from the grid, or exporting excess PV production to the grid. This process is known as self-consumption. This study compares the levels of self-consumption in a PV self-consumption system with and without the use of battery-based energy storage. It also compares four different load shifting load profiles against a baseline load profile without load shifting.

Key Words: Solar, Pv, Grid, Autoselection.

1. INTRODUCTION

As energy generation and distribution companies compete in the market place, we have seen an increasing interest in renewable and alternative energy sources. In addition to this competition, companies are seeking demands from customers for higher quality and cleaner electricity. Also, considering the world's coal stocks are reducing and the creation of legislation which is pushing for greener energy solutions, we are led to seek new energy generation methods. One solution which is currently attracting attention is Micro-Grid systems [1]-[2]. A Micro-Grid is a low voltage or medium voltage distribution network which consists of a cluster of micro sources/distributed

generators, energy storage systems and loads, operating as a single controllable system. In a MG, the distributed generators should have sufficient capacity to carry all, or most, of the load connected to the MG. Distributed generators are located at strategic points, normally at the distribution level, near load centres, and used for capacity support, voltage support and regulation, and line loss reduction [2]. The micro-sources or distributed generators are usually made of many new technologies, e.g. fuel cell, photo-voltaic system and several kinds of wind turbines. These units having small capacities are interfaced with power electronics and are placed at the consumer sites. Power electronics provides the control and flexibility required by the micro grid system. The inclusion of energy storage systems (batteries/flywheels/super capacitors) in a Micro grid system allows the excess power produced, to be stored or alternatively the excess power could be put into the main grid [3]-[4]. Micro-grid is inevitable in future due to its obvious advantages in reduced central generation capacity, increased utilization of transmission & distribution capacity, enhanced system security and reduced CO₂ emission. However, micro-grid adds a number of complexities in control and protection aspects in a traditional distribution system.

Fig. 1.1 shows that the global Solar-PV installation capacity has been exponentially increasing over the past two decades, recording 237.3 GW in 2015. This represents more than tripling of its global capacity in 2011[2]. Utilization of Solar-PV systems has gained global acceptance for several reasons, i.e., availability of solar irradiance in many regions, absence of moving parts in the generation system, decline of PV panel's cost, and low operation and maintenance costs. However, Solar-PV units are intermittent source of power due to the unexpected solar irradiance change and temperature. Strategically, Battery Energy Storage System (BESS) can play a salient role in a microgrid by addressing any mismatch between the intermittent Solar-PV generation and power demand. BESS also can provide ancillary services such as voltage and frequency regulation, reactive power support, load leveling, peak shaving, and power quality improvement [3].

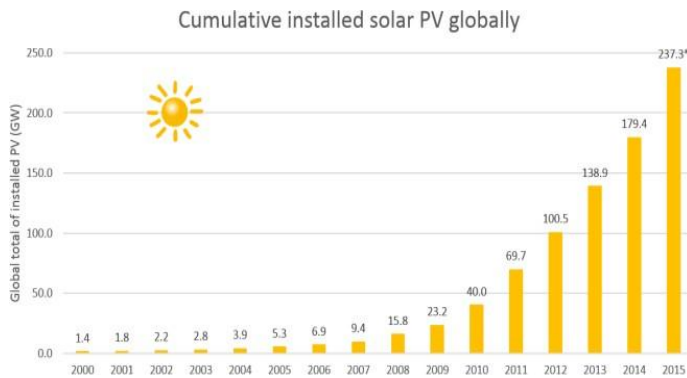

Figure 1. 1: Total installed Solar-PV around the world for the past 15 years [2].

2. LITERATURE REVIEW

G. Suresh (2018) proposed on this paper, a manage method for energy glide management of a lattice related go breed PV battery-primarily based gadget with a productive multi-enter transformer coupled bidirectional dc-dc converter is brought. The proposed gadget expects to fulfil the heap request, address the strength glide from numerous resources, infuse surplus strength into the lattice and rate the battery from matrix as and while required.

Ramendra Kumar et al. (2018) proposed hybrid electricity system may be utilised to decrease energy storage wishes. There's increasing hobby for using exchange or belongings strength resources to perform accurate and ease strength for Residential Application the PV hybrid device restores the most decreased value esteems to stay up an equal degree of DPSP once contrasted with independent sun and structures. For all heap requests the leveled strength taken a toll for PV hybrid gadget is reliably beneath that of independent sun PV or gadget.

J. Mano Priya and T. Narasimha Prasad (2018) proposed a grid-related hybrid system inclusive of photovoltaic (PV) array, turbine, and battery storage are considered and a control strategy for power glide management of the considered hybrid machine with an efficient transformer-coupled bidirectional dc-dc converter is presented. This transformer is used to interface the non-traditional electricity assets to the main dc bus of the device.

Rohan R. Pote and Dipti D. Patil (2017) proposed the traditional method for the mixing of more than one renewable resources and power input converters for every source and calls for a greater range of converter stages main to sizeable reduction in reliability and performance of the gadget. In order to deal with this problem, a energy flow management battery-primarily based grid connected unmarried section electricity generating dc converter is proposed.

M. Bijomerlin et al. (2017) presented efficient use of hybrid strength for three phase domestic packages is presented on this paper. The proposed hybrid machine manages the energy waft from sun -battery resources and the battery is charged when required from the grid. The proposed converter includes a half bridge converter to harness the power from sun and battery thru bidirectional greenback-improve converter and energy from thru the diode rectifier.

Amit Kumar Gupta et al. [54], cautioned a simple SVPWM set of rules for a multilevel inverter for operation within the over modulation variety. The proposed scheme easily determines the vicinity of the reference vector and calculates on-instances.

3. PROPOSED METHODOLOGY:

3.1 Grid-Connected Mode Control Strategy:

In the grid-connected mode of operation, the microgrid's voltage and frequency are determined by the utility grid. The grid supplies any power deficit and absorbs any surplus power of the microgrid system. The proposed control strategy regulates the solar-PV units to exchange real and reactive power with the microgrid through the current controller of their VSC systems while tracking their MPPs. The control strategy also controls the BESS to satisfy its SOC constraints while regulating the active and reactive power through the current controller of its VSC system. The control strategy in the grid-connected mode has two main functions. i) extracting the maximum output power from the three Solar-PV units based on their MPPT controls. ii) controlling the battery SOC at a certain level which can support the microgrid voltage and frequency in the islanded mode. The proposed control strategy attempts to keep the BESS in the grid-connected mode in an idle state, i.e., neither charging nor discharging, which reduces the number of charging/discharging cycles and extends battery life [33].

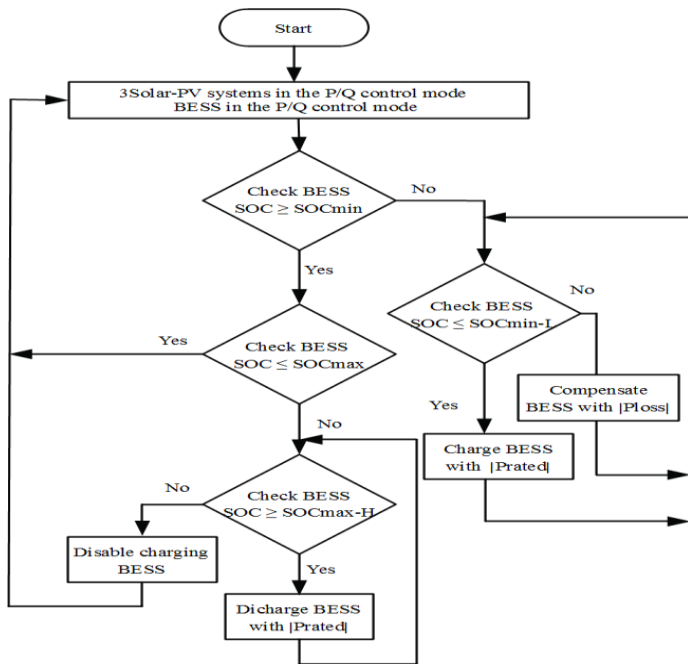

Figure 2: The proposed control strategy for the microgrid system in the grid-connected mode.

3.2 Solar-PV Unit Control

Figure 3 shows the LC of each Solar-PV unit which includes a Maximum Power Point Tracking (MPPT) control, a DC Voltage controller and the VSC system control. The MPPT provides the reference DC voltage to the DC voltage controller. The DC voltage controller generates the reference real power (P_{s_ref}) for the VSC system control. The current controller of the VSC system controls the VSC output power to track the AC power reference generated from the DC voltage controller by providing the modulation indexes for the SPWM scheme of the VSC. In this thesis, it is assumed that there is no reactive power support provided by the Solar-PV units, i.e., the SC sets the reference reactive power (Q_{s_ref}) of the Solar-PV units to be zero.

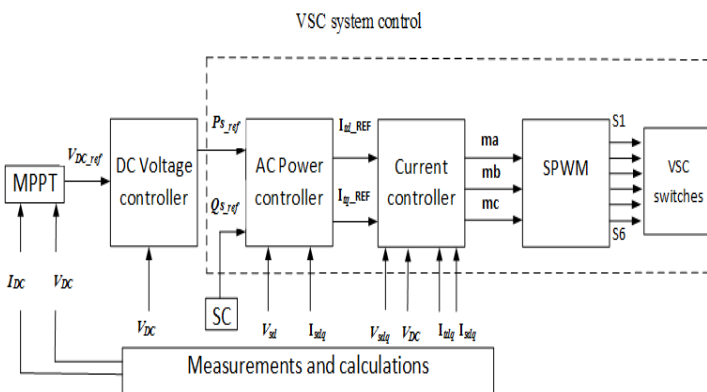

Figure 3: Schematic diagram of the control system of each Solar-PV unit.

3.3 BESS Control

Figure 4 depicts the control structure of the BESS. The LC comprises a SOC constraints logic and the VSC system control. The SOC constraints logic provides the reference real power while the SC provides the reference reactive power to the VSC system. In this thesis, it is assumed that there is no reactive power support provided by the BESS in the grid connected mode, therefore, the SC sets the reference reactive power (Q_{s_ref}) of the BESS to zero.

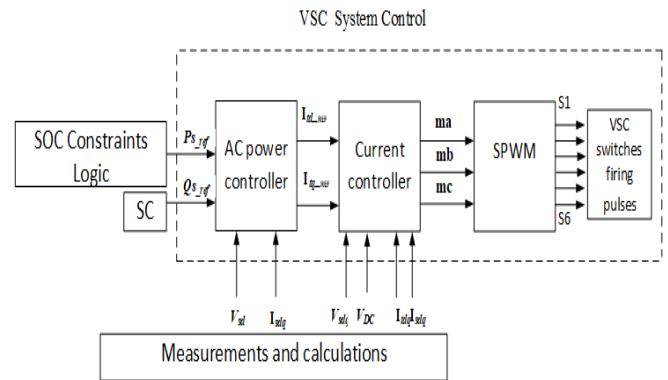

Figure 4: Schematic diagram of the control system of the BESS.

3.4 Variable Solar Irradiance

Figure 5 (a) shows real power exchange of the three Solar-PV units and the BESS with the utility grid. The three Solar-PV units operate under similar conditions and thus, their output power curves are overlapped. The simulation starts, when each Solar-PV unit supplies 0.4 pu to the microgrid, the utility grid supplies 0.51 pu to the microgrid and the battery initial SOC is 0.73, which is within the pre-specified range (70% - 75%). Thus, the BESS output power is zero during this case and the SOC remains constant as shown in Fig. 5 (b).

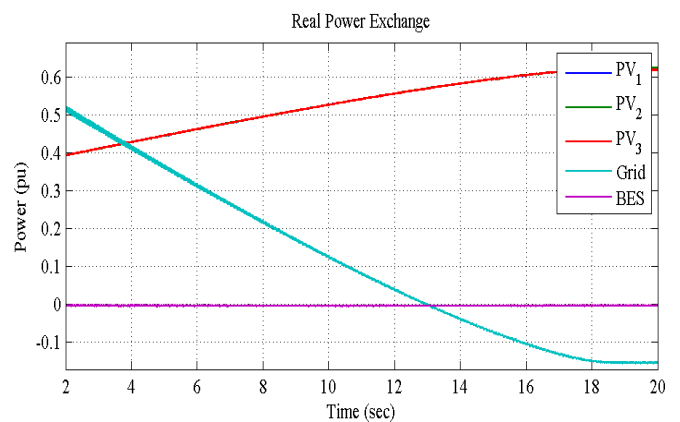

Figure 5 (a) Real power exchange between the three Solar-PV systems, the utility grid, and the BESS when the battery is idle (pu)

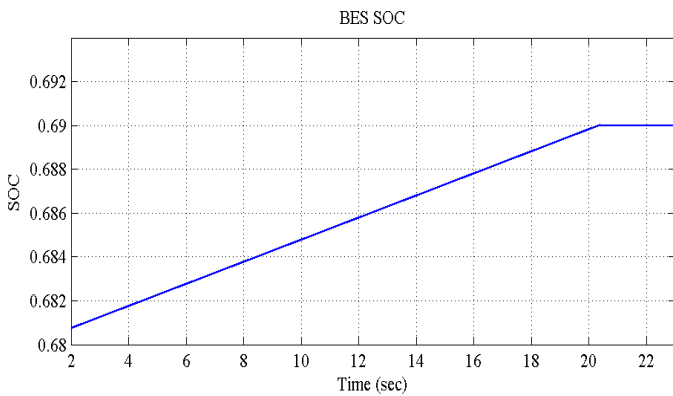

Figure 5 (b) Battery SOC is within the pre-specified range (0.73)

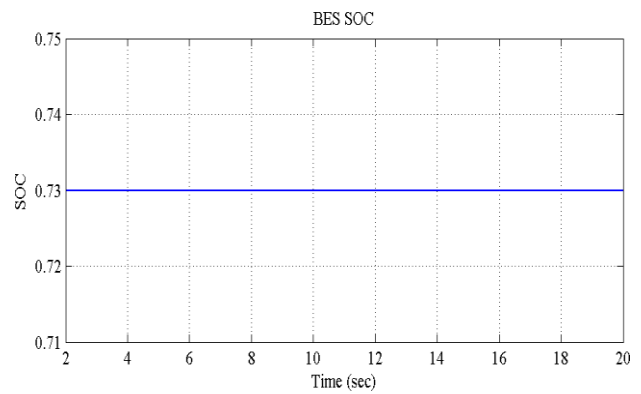

Figure 6 (b) Battery is charging under the SOC control scheme till it reaches the pre-specified range,

3.5 BESS Charging Mode

Figure 6 (a) shows the active power exchange of the three Solar-PV units and the BESS with the utility grid. In this case, the simulation starts when each Solar-PV unit supplies 0.4 pu to the microgrid system, the grid supplies 1.35 pu, and the BESS initial SOC is 0.6817 which is lower than the specified SOC_{min-L}(0.69). Consequently, the battery starts charging at the rated power as shown in Fig. 4.12 (a) until SOC meets the lower limit at $t = 20.4$ sec and becomes constant again as shown in Figure 6 (b)

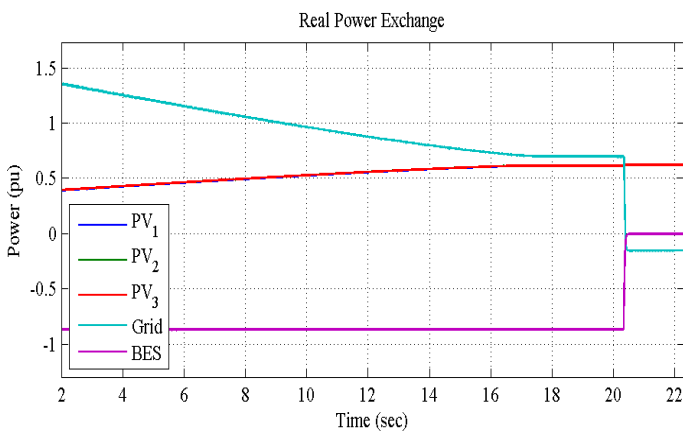

Figure 6 (a) Real power of the three Solar-PV systems, the utility grid, and the BESS when the battery is under the charging mode (pu)

4. RESULT

Figure 7 Show the microgrid model of the system with 1mw solar plant , BESS controller and power grid. All the output can be seen in Scope of the system.

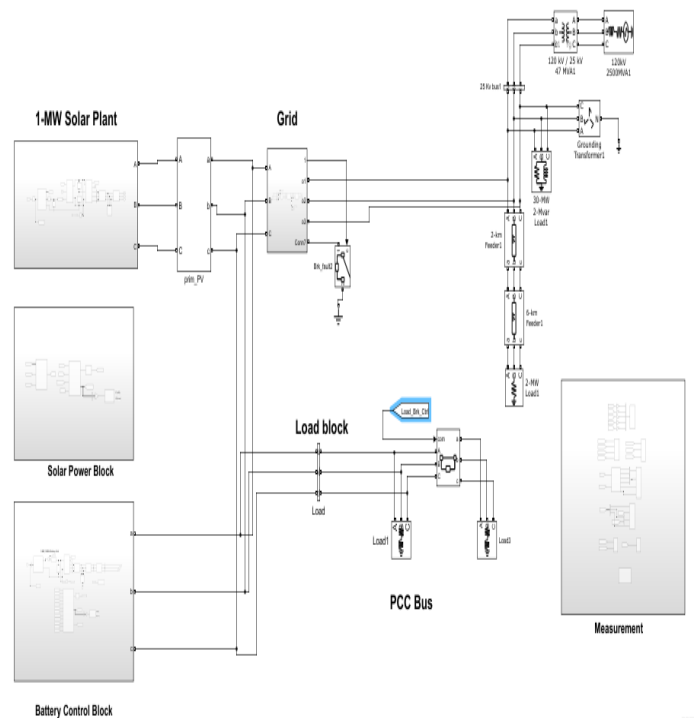

Figure 7: Simulink model of microgrid

Only the voltage between the terminals of the battery is selected due to it has been modelled as a controllable voltage source. Hence the value is set up to $EDC_B = 800$ V, that is according to the power range that the converter is operating on. For the VSC converter of the battery system the values for the inductance equivalent resistances are also $r_l = 0,5 \Omega$ and the inductances values are $l_l = 5,4$ mH. The active power reference values will depend on the

function of the battery and will be described for each simulation.

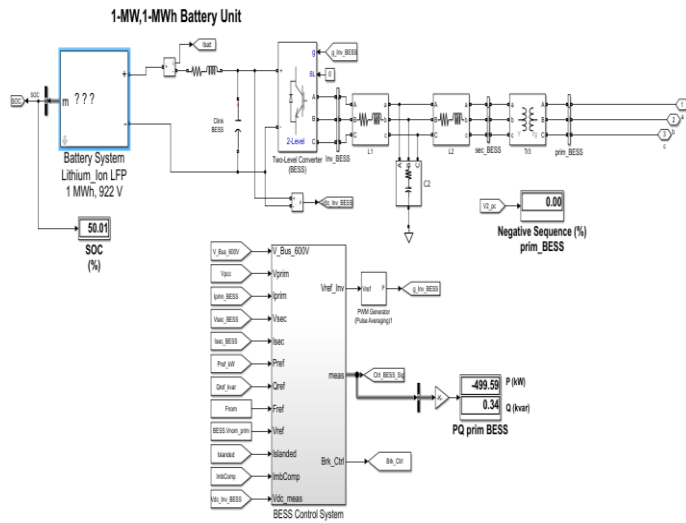

Figure 8 Battery back Unit

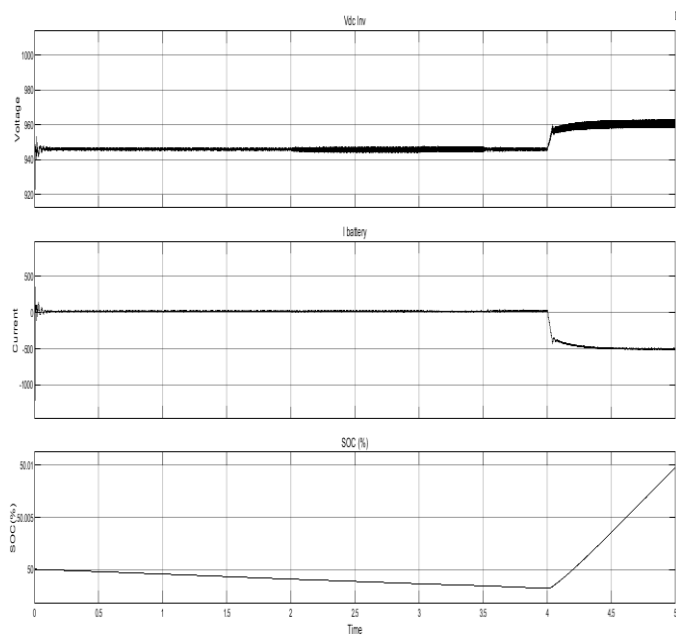

Figure 9 Voltage, current and SOC of the battery.

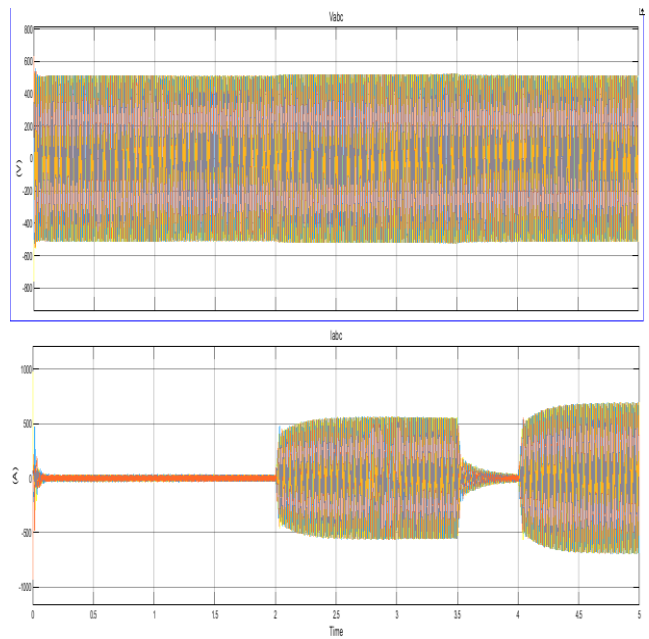

Figure 10 Voltage, current Of BESS inverter Output

Figure 11 Shows over all working of the system along with load Current remain constant . to maintain this system, compensate the error by taking current in account using from available source of the system.

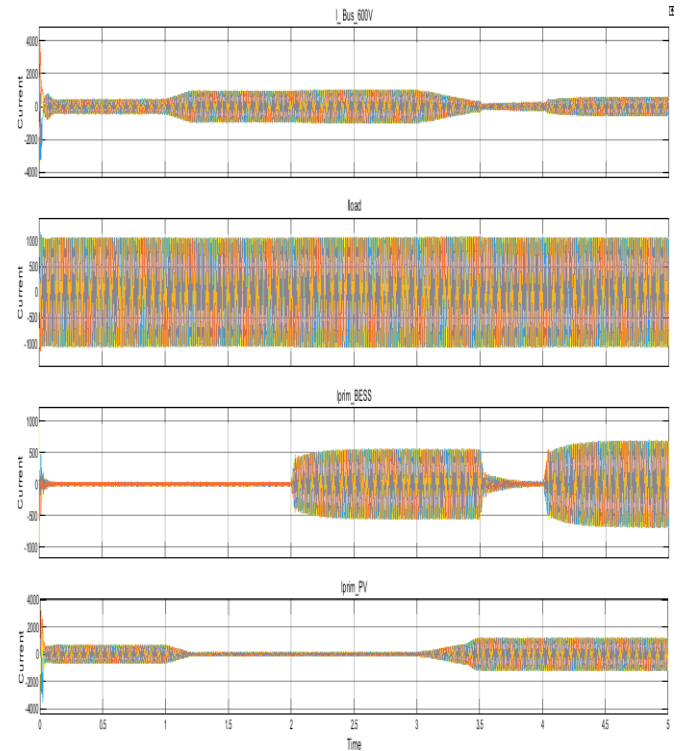

Figure 11 Current Variation of system Solar, grid, BESS to maintain load current.

5. Conclusion

This Paper proposes a control strategy for a microgrid system integrated with multiple Solar-PV units and BESS when it is disconnected from the utility grid. The control strategy enables the transfer from the grid-connected mode to the islanded mode, assigns the BESS to maintain the voltage and frequency of the islanded microgrid and reconnects to the utility grid.

REFERENCES

- [1] N. Hatziargyriou, H. Asano, R. Iravani and C. Marnay, "Microgrids," in *IEEE Power and Energy Magazine*, vol. 5, no. 4, pp. 78-94, July-Aug. 2007.
- [2] Global Market Outlook for Photovoltaics 2014-2018 (EPIA, 2014)& Global Market Outlook for Solar Power 2015-2019 (SSE, 2014).
- [3] David Wenzhong Gao, "Energy Storage for Sustainable Microgrid," Chapter 2, *Elsevier Ltd*, 2015.
- [4] N. D. Hatziargyriou and A. P. Sakis Meliopoulos, "Distributed energy sources: technical challenges," 2002 IEEE Power Engineering Society Winter Meeting. Conference Proceedings (Cat. No.02CH37309), 2002, pp. 1017-1022 vol.2.
- [5] D. Olivares, A. Mehrizi-Sani, A. Etemadi, C. Canizares, R. Iravani, M. Kazerani, A. Hajimiragha, O. Gomis-Bellmunt, M. Saeedifard, R. Palma-Behnke, G. Jimenez-Estevez, and N. Hatziargyriou, "Trends in Microgrid control," *IEEE Trans. Smart Grid*, vol. 5, no. 4, pp. 1905- 1919, Jul. 2014.
- [6] F. Katiraei and J. R. Aguero, "Solar PV Integration Challenges," in *IEEE Power and Energy Magazine*, vol. 9, no. 3, pp. 62-71, May-June 2011.
- [7] J. A. P. Lopes, C. L. Moreira and A. G. Madureira, "Defining control strategies for Microgrids islanded operation," in *IEEE Transactions on Power Systems*, vol. 21, no. 2, pp. 916-924, May 2006.
- [8] X. Chen, Y. Hou, S. C. Tan, C. K. Lee and S. Y. R. Hui, "Mitigating Voltage and Frequency Fluctuation in Microgrids Using Electric Springs," in *IEEE Transactions on Smart Grid*, vol. 6, no. 2, pp. 508-515, March 2015.
- [9] L. Xu, Z. Miao and L. Fan, "Control of a Battery system to improve operation of a microgrid," *2012 IEEE Power and Energy Society General Meeting*, San Diego, CA, 2012, pp. 1-8.
- [10] I. Serban and C. Marinescu, "Control Strategy of Three-Phase Battery Energy Storage Systems for Frequency Support in Microgrids and with Uninterrupted Supply of Local Loads," in *IEEE Transactions on Power Electronics*, vol. 29, no. 9, pp. 5010-5020, Sept. 2014.
- [11] Marc Beaudin, Hamidreza Zareipour, Anthony Schellenberglabe, William Rosehart, "Energy storage for mitigating the variability of renewable electricity sources: An updated review", *Energy for Sustainable Development*, Volume 14, Issue 4, December 2010.
- [12] S. Teleke, M. E. Baran, S. Bhattacharya and A. Q. Huang, "Rule-Based Control of Battery Energy Storage for Dispatching Intermittent Renewable Sources," in *IEEE Transactions on Sustainable Energy*, vol. 1, no. 3, pp. 117-124, Oct. 2010.
- [13] Z. Miao, L. Xu, V. R. Disfani and L. Fan, "An SOC-Based Battery Management System for Microgrids," in *IEEE Transactions on Smart Grid*, vol. 5, no. 2, pp. 966-973, March 2014. doi: 10.1109/TSG.2013.2279638.
- [14] Abigail Susan Hayhoe, "Impact of Irradiance Change on MPPT and Flicker Phenomenon of Solar-PV Systems," *Master's thesis, University of Toronto*, 2016.
- [15] Frank Hohlbaum, Markus Braendle, and Fernando Alvarez, "Cyber Security Practical considerations for implementing IEC 62351," ABB Switzerland, frank.hohlbaum@ch.abb.com
- [16] IEEE Guide for Planning DC Links Terminating at AC Locations Having Low Short-Circuit Capacities, IEEE Std 1204-1997.
- [17] R. A. Kordkheili, B. Bak-Jensen, J. R-Pillai and P. Mahat, "Determining maximum photovoltaic penetration in a distribution grid considering grid operation limits," 2014 IEEE PES General Meeting| Conference & Exposition, National Harbor, MD, 2014, pp. 1-5.
- [18] IEC 60904-3:2016 RLV Redline Version Photovoltaic devices - Part 3: Measurement principles for terrestrial photovoltaic (PV) solar devices with reference spectral irradiance data
- [19] https://hvdc.ca/uploads/ck/files/reference_material/PSCAD_User_Guide_v4_3_1.pdf.

[20] A. Yazdani et al., "Modeling Guidelines and a Benchmark for Power System Simulation Studies of Three-Phase Single-Stage Photovoltaic Systems," in IEEE Transactions on Power Delivery, vol. 26, no. 2, pp. 1247-1264, April 2011.

[21] Digambar M. Tagare, "Photovoltaic Energy Solar Cells and Solar Power Systems," in Electricity Power Generation: The Changing Dimensions ,1, Wiley-IEEE Press, 2011, pp.195-216 doi: 10.1002/9780470872659.ch10

[22] M. G. Villalva, J. R. Gazoli, and E. R. Filho, "Comprehensive Approach to Modeling and Simulation of Photovoltaic Arrays," in IEEE Transactions on Power Electronics, vol. 24, no. 5, pp. 1198-1208, May 2009.

[23] E. Muljadi, M. Singh, and V. Gevorgian, "PSCAD Modules Representing PV Generator," *National Renewable Energy Laboratory*, Technical Report August 2013.

[24] Ned Mohan, Tore M. Undeland, and William P. Robbins, " Power Electronics Converters, Applications, and Design," Wiley, 2003.