

# Design and Development of Foot Step Power Generator as an Alternative Source of Energy

Atharva Y. Pol<sup>1</sup>, Dhiraj P. Patil<sup>2</sup>, Harshal J. Patil<sup>3</sup>, Pravin B. Moholkar<sup>4</sup>  
Prof. Kunal S. Marathe<sup>5</sup>

<sup>1, 2, 3, 4</sup> Dr. D. Y. Patil School of Engineering, Lohegaon, Pune

<sup>5</sup> Professor, Department of Mechanical Engineering Dr. D. Y. Patil School of Engineering, Lohegaon, Pune, Maharashtra, India

\*\*\*

**ABSTRACT** : Energy is defined as the capacity of a system to perform and give the work output. Energy exists around us in many forms. These forms of energy can be harvested in many states as the law of conservation of energy states – Energy can neither be created, nor be destroyed, but can be transformed from one form to another. In short, the energy gets converted into the other form with the help of a stimulus, whether internal or external. This stimulus can be in the form of heat, sound, waves, flow and many varied forms and states. Effective harvesting of energy is what is necessary for today's world. Conclusively, we have worked upon a similar exemplar project of effective energy tapping from the people who walk. Considering our height constraint, we have developed a foot step power generator using rack and pinion arrangement, which is derivative, but effective way for the energy generation and providing mechanical stability to the overall system. Additionally, we have used helical springs, bearings, and shaft as the basic mechanical components in the project.

**Key Words** – Effective Harvesting, Rack and Pinion, Helical Springs, Gears, Shaft.

## 1. INTRODUCTION :

Now a days, energy and power are the primitive needs in the modern world. Taking into consideration the demand for increase in energy consumption, there is a need for sustainable energy conversion and renewing energy resources. On the contrary, some energy is wasted or is not effectively converted into the other reusable form. Energy is the most vital part of any system which exists in this universe. In today's world, there are almost various kinds of power generating sources available which contribute to the total power generation across the world which result in the useful energy which is utilized by the various factors in the world such as large projects, aerospace applications, daily purposes, machining requirements, nuclear purposes and many more such big applications. The main reason these systems are intact and working efficiently is because of

the energy which is supplied to them in many forms. Generation of energy or power to run these systems require ample of raw elements which get processed in order to generate power. Conventionally, coal was used as a major source of energy, but due to its adverse effects on the environment, it is now used in much less quantity comparing the use of coals in the past years. Similarly many ways are being planned, discovered in order to harvest clean and green energy which can promote the same requirement but without any adverse effects on the environment. Hence for the proper utilization of energy, the energy given out by the foot of a human being while walking, can be utilized effectively in public places like railway stations, bus stations. Also it is an advantage for densely populated country like India to implement this project in many areas. Also taking into consideration the diminishing coal supply throughout the powerplants, this energy conversion can be a boon to the future energy requirements. In reference to this, we are going to implement this type of project in our college campus, where there will be an alternate source of energy, which will help in reduced use of conventional energy. This will be implemented in the college campus, near the entrance, where people can opt for the eco-friendly charging facility which will be powered by this setup. Also in the future, there will be much more additions to this idea.

## 2. METHODOLOGY :

The main mechanism to be used is the rack and pinion mechanism. The rack and pinion mechanism can also be substituted by the chain and sprocket mechanism. The base frame will include the mechanism and a surface plate attached with the bracket support. In order to ensure the stability of the system, the surface plate is to be kept inclined by certain degrees in order to avoid the discomfort when someone steps on the assembly. The surface plate is also supported by the springs to ensure smooth sliding between the rack and the pinion and also helps in enhancing the stability. The rack and pinion assembly is to be connected to a dynamo, wherein the

generation of electricity will take place. This generated electricity will be stored in a battery, which will effectively serve to the outlets. To increase efficiency of the power generation, piezoelectric material can be attached to the base of the springs where load concentration takes place at certain value. The piezoelectric material will be layered on the upper plate and also on the springs in order to achieve more charge, resulting in increasing the efficiency of the overall generator. The expected output for this arrangement is about 3 to 4 V considering the two dynamo motors. In case of the real model, the output voltage can be increased by attaching multiple sets of rack and pinion and dynamo motors. Also one method to enhance the efficiency is increasing the number of teeth on the spur gear set which will ultimately cater to the increase in number of rotations per stroke and which will ultimately generate more output voltage.

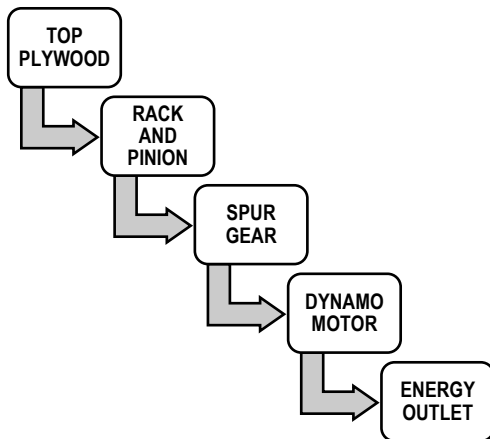

Figure 1 – Methodology

### 3. ANALYTICAL WORK

Analytical work includes finding the force on the upper plate, the theoretical output generated by the dynamo. For this, we will have to consider the average weight of Indian man as the force on the top plate, inclusive of the acceleration due to gravity. Due to the applied force, there will be a displacement of some units, resulting into the compression of the spring attached to the top plate, supporting the main frame.

Consider the average weight of the person standing or walking through the top plate is 70 kg. Considering 120 persons walking on the footstep power generator per hour. To determine the output power it is necessary to calculate the applied force. Let 'F' be the Force applied on the top plate. But the force applied is equivalent to the weight of the person walking on the top plate.

$$F = W$$

$$\therefore F = m \times g$$

$$\therefore F = 70 \times 9.81$$

$$\therefore F = 686.7 \text{ N}$$

Now, we have to calculate the Work done 'W', considering the above obtained force. Work done is applied force multiplied by the displacement occurred with the spring. Considering the Displacement 's', being 0.05 m, we have the following calculations.

$$W = F \times s$$

$$\therefore W = 686.7 \times 0.05$$

$$\therefore W = 34.335 \text{ J}$$

Now, we have to calculate the power output 'P' with respect to time 't'. Considering Time 't' as one minute, hence taking  $t = 60 \text{ s}$ , we have the following calculations.

$$P = \frac{W}{T}$$

$$\therefore P = \frac{34.335}{60}$$

$$\therefore P = 0.57225 \text{ watts}$$

### 4. DESIGN AND DEVELOPMENT

1) **Gears** – The design of gears has been done on the basis if the load which is going to act upon the top plywood which ultimately will be transmitted through the rack into the meshed spur gears. But in our case, the scope for the total revolution of the driven gear is not satisfied due to the height constraints of the base frame which has been taken according to the height of the actual constructed step. Hence, our primary motive is that the driven gear should at least complete 2/4<sup>th</sup> or 3/4<sup>th</sup> of rotation when the rack slides over the driver gear. The arrangement of gears is in series – the rack, the pinion having 36 teeth and a spur gear which is to be attached on the dynamo motor which has 12 teeth. The gear ratio occurring with the two circular spur gears is 1:3, indicating that the one rotation of the pinion attached with the rack will correspond to 3 rotations of the spur gear attached to the dynamo.

2) **Shaft** – Shaft is the rotating element. In our case, the shaft will home two spur gears which will be

rotating with the help of rack and pinion system. The gear which are mounted on the shafts have 36 teeth, and the rack length is 145 mm and has 22 teeth. Generally, shafts are designed on the basis of Torsion and Bending. In our case, the shaft is being designed on the basis of Bending because the number of rotations of the shaft are less. Considering the length of the shaft as 1300 mm.

- 3) **Bearings** – For the shaft to rotate when the force is applied, there are two bearings attached at either side of the base frame. The shaft is supported by the two bearings. Considering the applied radial force to be 2060 N, and number of rotations as 10, we obtain the value of dynamic load as 5400 N and therefore, for the above value of dynamic load, according to the table of Dimensions and Static Dynamic Load Capacities of Ball Bearings, we have six different types of bearings – 61805, 16005, 6005, 6205, 6305 and 6405. So, according to the obtained value, we have chosen the 16005 Designation Bearing for our application.
- 4) **Helical Springs** – Helical springs will be supporting the top plywood from the inclined side. Springs are utilized for the rack movement in the vertical direction. As someone steps on the platform, the springs activate and compress due to the weight of the person standing and also retract when the applied load is removed. Considering the weight of the person standing is 70 kg. By calculations with the standard design procedure, the wire diameter obtained is 5 mm and coil diameter obtained is 50 mm.
- 5) **Base Frame** – Base frame measures 1300 mm × 600 mm × 185 mm. The base frame is made up of square tube of mild steel which has a cross sectional area of 30 mm × 30 mm.
- 6) **Top Plywood** – A top hard wood plywood will serve as a flat terrain for people to walk on. It is a 1300 mm × 600 mm rectangular ply with thickness 20 mm. The plywood will be furnished with waterproof paint in order to prevent the wearing of wood due to dampness.
- 7) **Battery** – The specification of the battery is chosen with respect to the minimum rotation given by the rack and pinion. The capacity of battery is 6 V. This battery can be externally charged too. The working time of the battery under fully charged condition is 2 hours. Also

this battery takes 20 minutes for a full capacity charge.

- 8) **Piezoelectric Transducers** – The working of piezoelectric material is that when force is applied on the surface area of the material, it generates electric charge which can be used. The piezoelectric sensor we have chosen has a circular surface area and will be attached onto the surface of the top plate and below the springs. Their connection will be sent to the dynamo motor. The specifications of the crystal are – Resonance Frequency = 4.6 KHz ± 0.5 KHz; Resonance Impedance = 200 Ω; Capacitance = 20 mF ± 30% at 1 KHz, and the dimensions are 2.7 × 2.7 × 0.1 cm. The reference image of the piezoelectric sensor is as follows. These piezoelectric transducers have been arranged in a series circuit array, which is to be placed on the top of the plywood.

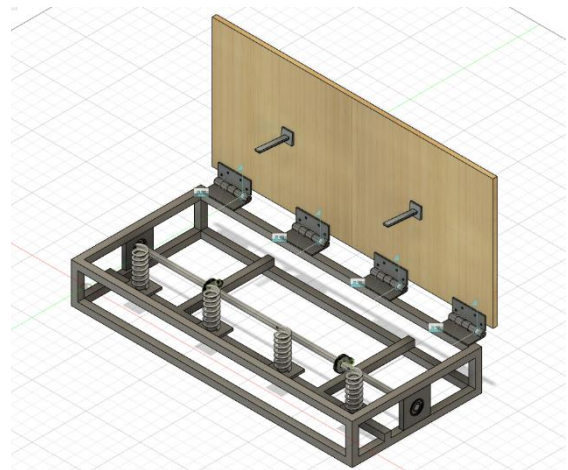

Figure 2 – Assembly of the Model

## 5. EXPERIMENTATION AND RESULTS

During the trials on the two dynamo motors (DC generators) we have acquired the following values through the digital multi meter which are tabulated as follows.

Table 1 – Load and Output

Sr. No.	Weight (kg)	Dynamo 1 (V)	Dynamo 2 (V)	Total (V)
1	50	0.24	0.22	0.46
2	55	0.52	0.54	1.06
3	60	0.75	0.72	1.47
4	65	1.04	1.06	2.1
5	70	1.24	1.22	2.46

Considering the obtained voltage output, it is clear that more the weight factor increases, more the voltage generation takes place. Considering the length of the platform, it is a case that more than one person can alight on the platform which can effectively increase the obtained output.

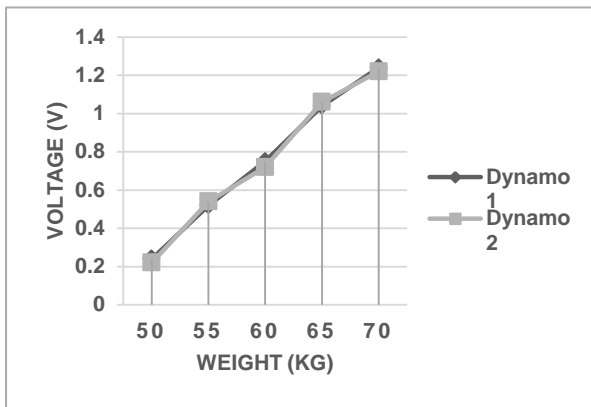

Chart 1 – Load and Output Analysis

## 6. CONCLUSION AND FUTURE SCOPE

The conversion of kinetic energy from human footsteps into the electricity energy is considered as one of the renewable energy techniques. This research had demonstrated the feasibility of generating electricity with simple mechanism of rack and pinion. Furthermore, this research proposed to place the mechanical footstep power generator at hind foot region in order to generate higher output power with better efficiency. During the first stage of the project, we have calculated the theoretical power output, which is to be compared with the actual acquired output we are going to get after the assembly procedure. For the conclusion, according to our given constraints of height, the prototype which we have designed would be producing power of about 4 to 5 volts per hour. The merging of the mechanical and electrical power producing sources have sufficiently enhanced the outlook of the prototype.

## ACKNOWLEDGEMENT

We are thankful to Prof. Kunal Marathe our Project Guide for encouraging and guiding us through this process of Project. The valuable guidance and constant positive attitude towards each and every student, including us has proved helpful during completion of this Project Report. We also whole heartedly thank our HOD Sir, Prof. Rohit Garad for making our base strong in the core subjects, which ultimately has created an ease while dealing with the subjects and theories apart from the regular curriculum. We would also like to thank each and

every teacher from the Mechanical Department for imparting knowledge in every possible way! We all are truly grateful to our Principal Sir, Dr. F. B. Sayyad for guiding us as well.

## REFERENCES

- 1) Mechanical Footstep Power Generation : *B.Munaswamy* <sup>[1]</sup>, *Ch.Prudhvi* <sup>[2]</sup>, *V.Srikanth* <sup>[3]</sup>, *B.Kirankumar* <sup>[4]</sup>, *E.Pradeep Kumar* <sup>[5]</sup> (International Journal of Engineering Trends and Applications (IJETA) Volume 5 Issue 2, Mar-Apr 2018)
- 2) Foot Step Power Generation : *Ajinkya V. Gothane* <sup>[1]</sup>, *Akshay R. Gosavi* <sup>[2]</sup>, *Prof. P. V. Raut* <sup>[3]</sup> (International Research Journal of Engineering and Technology (IRJET) Volume 05 Issue: 12 Dec 2018)
- 3) Design of Footstep Power Generation System using Rack and Pinion gears mechanism : *Muhammad Asad Saeed* <sup>[1]</sup>, *Muhammad Hamza Tahir* <sup>[2]</sup>, *Nouman Zaffar* <sup>[3]</sup>, *Arslan Malik* <sup>[4]</sup> (Published Online June 2019 in IJEAST)
- 4) Development of a footstep power generator in converting kinetic energy to Electricity : *Chun Kit Ang*, *Ammar A. Al-Talib*<sup>[1]</sup>, *Sook Meng Tai*<sup>[2]</sup>, and *Wei Hong Lim*<sup>[3]</sup> (E3S Web of Conferences)
- 5) Mechanical Footstep Power Generator : *Mohammed Saleh Aljohani* <sup>[1]</sup>, *Faisal Alonazi* <sup>[2]</sup> (Central Washington University)
- 6) Government of India - Ministry of Power (<https://powermin.gov.in>)
- 7) Relationship between electricity consumption, trade openness and economic growth in India : *Ramphul Ohlan*, Institute of Management Studies and Research, Maharshi Dayanand University, Rohtak, Haryana, India.
- 8) A Novel Method for Electricity Generation from Footsteps Using Piezoelectric Transducers : *D Sathish* <sup>[1]</sup>, *C. Srisailam* <sup>[2]</sup>, *D. Harsha* <sup>[3]</sup>, *K. Murlidhar Goud* <sup>[4]</sup> (Turkish Journal of Computer and Mathematics Education)
- 9) Nanomotion - A Johnson Electric Company (<https://www.nanomotion.com>)
- 10) ELPROCUS (<https://www.elprocus.com>)
- 11) Optimal Beam (<https://optimalbeam.com>)
- 12) V. B. Bhandari - Design of Machine Elements (McGraw Hill Publications)