

## Sand Filling Pneumatic Machine

**Sarvesh Malakollikar<sup>1</sup>, Rishikesh Mishra<sup>1</sup>, Prf Unmesh Chavan<sup>2</sup>, Er Moolchand Nahariya<sup>3</sup>, Er Venu Gopal Rao<sup>3</sup>**

<sup>1</sup>*B.Tech. Student, Department of Mechanical Engineering, Vishwakarma Institute of Technology (VIT), Pune, Maharashtra, India*

<sup>2</sup>*Assistant Professor, Department of Mechanical Engineering, Vishwakarma Institute of Technology (VIT), Pune, Maharashtra, India*

<sup>3</sup>*Chief Instructor, Diesel Training Centre, Diesel Loco Shed (IR), Pune, Maharashtra, India*

\*\*\*

**Abstract** - Indian Railways is the state-owned railway company of India having more than 64000 Kilometres of track and 6909 stations. It has the world's 4th largest railway network after that of United States, Russia, and China. It carries over 20 million passengers and 2 million tons of freight daily. It is one of the world's largest commercial employers with more than 1.6 million employees. It owns over 200000 freight wagons, 50000 coaches and 10000+ locomotives.

**Key Words:** soft robots, pneumatically, finger, prosthetics

### 1. INTRODUCTION

Indian Railways owns over 250000+ locomotives running all over India. When we were doing internship at Diesel loco Shed Pune, we came across one problem that was FILLING OF SAND IN LOCO. One Loco consist of 8 Sand box with each sand box weighing 50 kgs resulting in total weight of 400 kgs. So, while filling the sand box there was human labour involved which resulted in loss of sand while filling the boxes. On an average for filling one sand box resulted in loss of approximately 10 kgs of sand. Mathematically if we calculate there is more than loss of 2500+ tons of sand resulting of Rs 3750000 as of 250000 engines. Daily more than 2 lacks locos are to be filled those results in loss of crores to Indian Railways.

### 2. LITERATURE REVIEW

So, studying the scenario we have designed a machine on pneumatic mechanism capable of filling the Loco of 400 kgs that requires unskilled labour, minimum maintenance, zero cost of operation. The machine is easy to manufacture and cost of manufacturing is quiet low. The main advantage of machine is that it has tank as a storage for compressed air as well input from loco can also be given which makes it a mobile machine fit for use. Hence this machine can be effectively implemented in Loco sheds which will increase the efficiency as well as reduce the wastage.

### A. SILICA SAND PROPERTIES:

Silica or silicon dioxide (SiO<sub>2</sub>) is a chemical compound consisting of one silicon and two oxygen atoms. Quartz is a common mineral with the same chemical composition, but quartz and silica are not synonyms. Specific minerals always have a definite crystal structure while chemical compounds have no such restriction — just like every piece of carbon is not a diamond. Quartz is made of silica but so are also cristobalite, tridymite and few other minerals (polymorphs of silica). They are collectively referred to as silica minerals. Quartz is the most common sand-forming mineral. However, it is not the most common mineral in the crust. That honour goes to feldspars. If the sand deposit contains almost nothing but quartz, we often call it a silica sand. Such sand deposits are said to be mature because other rock-forming minerals are already broken down by the weathering process leaving only the super-resistant quartz as a residue. Silica sand is a mineral resource. It is mined mostly for glassmaking. Another major use of sand is a concrete production but that does not need sand to be as pure.



**Fig - 1:** Silica Sand Image

Some beautiful beaches are made of silica sand. Beach of Siesta Key in Florida is especially famous for its white sand. Not all white sands are made of silica, though. White Sands National Monument in New Mexico is a dune field which is composed of sand made of gypsum. There are lots

of light-coloured beach sands around the world but many of them (especially in low latitudes) are made of small pieces of corals and other sea creatures. This sand is calcareous (composed of calcium carbonate) but some biogenic grains are siliceous as well. For example, radiolarians (amoeboid protozoa) and diatoms (algae) have siliceous shells.

**B. STRUCTURE OF SILICA SAND-**

In most silicates, the silicon atom shows tetrahedral coordination, with four oxygen atoms surrounding a central Si atom (see 3-D Unit Cell). Thus, SiO<sub>2</sub> forms 3-dimensional network solids in which each silicon atom is covalently bonded in a tetrahedral manner to 4 oxygen atoms. In contrast, CO<sub>2</sub> is a linear molecule. The starkly different structures of the dioxides of carbon and silicon are a manifestation of the Double bond rule.

SiO<sub>2</sub> has several distinct crystalline forms, but they almost always have the same local structure around Si and O. In α-quartz the Si-O bond length is 161 pm, whereas in α-tridymite it is in the range 154–171 pm. The Si-O-Si angle also varies between a low value of 140° in α-tridymite, up to 180° in β-tridymite. In α-quartz, the Si-O-Si angle is 144°

Properties	
Chemical formula	SiO <sub>2</sub>
Molar mass	60.08 g/mol
Appearance	Transparent solid (Amorphous) White/Whitish Yellow (Powder/Sand)
Density	2.648 (α-quartz), 2.196 (amorphous) g·cm <sup>-3</sup> [1]
Melting point	1,713 °C (3,115 °F; 1,986 K) (amorphous)[1]: 4.88 to
Boiling point	2,950 °C (5,340 °F; 3,220 K)[1]
Magnetic susceptibility (χ)	-29.6·10 <sup>-6</sup> cm <sup>3</sup> /mol
Thermal conductivity	12 (   c-axis), 6.8 (⊥ c-axis), 1.4 (am.) W/(m·K)[1]: 12.213
Refractive index (n <sub>D</sub> )	1.544 (o), 1.553 (e)[1]: 4.143

Fig - 3: Silica Sand Property Table

**C. AVAILIBILITY OF SILICA SAND IN INDIA:**

According to Indian Minerals Yearbook, the production of silica sand in 2021 is estimated to around 8621.6 thousand metric ton. India’s silica sand market is expected

to increase at a healthy growth rate because of the growing construction and foundry industry. The silica sand market is partially consolidated. Silica Sand is geologically available in particularly excellent quality in Andhra Pradesh, India. Our company is considered the most pioneer in Silica sand mining industry. Silica Sand is consumed in substantial number of industries in different forms.



Fig - 4: Silica Sand Refinery Plant

**D. Use of Silica Sand in Loco:**

As locomotives run on a railway track, there is always friction which makes possible the movement of locomotives but there are few cases where there is loss of friction and therefore to maintain friction and swift movement of locomotives, the silica sand is used.

Conditions that cause loss of Friction

- 1) Heavy Loadings
- 2) Uneven landforms due to geo-graphical locations
- 3) Low weight of Electric Locos, resulting in low tractive efforts
- 4) Demanding Breaking Conditions
- 5) Humid & Rainy conditions.

The above-mentioned conditions cause loss of friction and to counter such challenges Silica sand is used and the advantage of using this lack of wear and tear of wheels.

**3. WORKING PRINCIPLE**

Sand Filling Pneumatic Machine works on the principle of the Venturi Pump, Principle behind the operation of the Venturi flowmeter is the **Bernoulli effect**. The Venturi measures a fluid’s flowrate by reducing the cross-sectional flow area in the flow path and generating a pressure difference.

Bernoulli’s principle states that an increase in the speed of a fluid occurs simultaneously with a decrease in static pressure or a decrease in the fluid’s potential energy A Venturi pump uses the kinetic energy in a fast-moving fluid to move another liquid or semi-liquid substance. The standard Venturi pumps are part of a



**Fig - 6:** CAD Design (Fusion 360 )

liquid system with atmospheric pressure. A modified version called the Venturi vacuum pump uses the same principles in vacuum pressure conditions. These pumps require a compressed air source, but no electricity. Venturi vacuum pumps make a lot of noise. People working near Venturi vacuum pumps need ear protection. These pumps are often installed at a distance to reduce noise pollution and to reduce additional power among workers in the area. Most Venturi vacuum pumps are small, and some are portable. These long-lasting pumps are

#### 4. DESIGN :

In the design of this system, we tried to make it convenient to move it around and take it to blazes at feeling and can't be brought back to shade to be refilled. The complete system is fixed up on a trolley which can be toured behind another vehicle. the trolley has 4 free spinning wheels which make it easy to handle.

The hopper is attached on the trolley with venturi pump at its base hopper has 2 sections one is the primary hopper second is the secondary hopper. The primary hopper work as the storage for sand and the secondary hopper work as delivery mechanism for venturi pump. The the venturi pump is fixed at the bottom of the upper to the secondary hopper and attached with 2 pipes first is the intake pipe which comes from the pneumatic storage tank the second is the outlet pipe which goes through the feeling nozzle for sand. The intake pipe is connected to the storage tank or compressor which will ideally provide a pressure of 15 to 20 PSI . The pressure can be generated

by compressor fixed on the trolley or can be taken from the pneumatic pipeline in the plant to fill the tank to decide pressure. The connecting pipe delivers the pressure from tank to venturi pump. The sand is slowly discharge from the secondary hopper into the top section of venturi pump where in the chamber did it get mixed with pneumatic pressure and is pushed forward by the phenomena called pneumatic conveying or venturi conveying. The mixture of sand and air can we send up to 10 meters in a pipeline diameter 10 centimetre. The pipe used for outlet must be a flexible pipe .

#### 6. COMPONENT

##### A. Hopper

A hopper is a pyramidal or cone-shaped vessel used in industrial processes to hold particle or flowable material of any kind (such as dust, rocks, nuts or seeds) and extract this from the ground where necessary. In some special applications even small parts of metal or plastic can be loaded and unloaded by small hopper systems. In the case of dust collectors hoppers dust can be collected in blown air. Dust collectors are usually grouped to allow for a larger collection. Hoppers are used in many industries to hold goods until they are needed, such as flour, sugar or nuts for food, animal feed pellets, milled ore for refining, etc. Dust hoppers are used in industries that use air pollution control equipment. such as dust collectors, electrostatic precipitators, and baghouse / cloth filters. Most hoppers are made of steel.



Fig - 6: CAD Design (Fusion 360 )

**B. Compressor:**

A pressure vessel is a container designed to hold gases or liquids at a pressure substantially different from the ambient pressure. Construction methods and materials may be chosen to suit the pressure application, and will depend on the size of the vessel, the contents, working pressure, mass constraints, and the number of items required. Pressure vessels can be dangerous, and fatal accidents have occurred in the history of their development and operation. Consequently, pressure vessel design, manufacture, and operation are regulated by engineering authorities backed by legislation. For these reasons, the definition of a pressure vessel varies from country to country. Design involves parameters such as maximum safe operating pressure and temperature, safety factor, corrosion allowance and minimum design temperature (for brittle fracture). Construction is tested using non-destructive testing, such as ultrasonic testing, radiography, and pressure tests. Hydrostatic pressure tests usually use water, but pneumatic tests use air or another gas. Hydrostatic testing is preferred, because it is a safer method, as much less energy is released if a fracture occurs during the test (water does not greatly increase its volume when rapid depressurization occurs, unlike gases, which expand explosively). Mass or batch production products will often have a representative sample tested to destruction in controlled conditions for quality assurance. Pressure relief devices may be fitted if the overall safety of the system is sufficiently enhanced.



Fig - 6: COMPRESSOR CAD DESIGN

**C. Venturi Pump**

A vacuum ejector, or simply ejector is a type of vacuum pump, which produces vacuum by means of the Venturi effect. Here sand from Hopper is redirected to Venturi pump and the air pressure from the tank acts as push which generates Venturi effect and the sand is pushed away

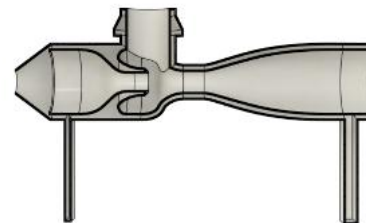

Fig - 6: Venturi pump Cross Section

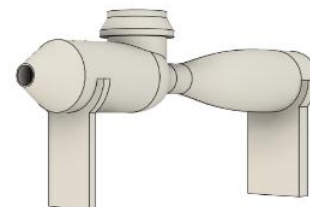

Fig - 6: Venturi pump

**D. Connecting pipe & Outlet Pipe**

Connecting pipes function as a linkage between compressor tank and Venturi pump which permits the flow of pneumatic pressure that initiates the sand flow

**Outlet Pipe**

It acts as a delivery pipe of the system work. The mixture of sand and air pressure paves its way through the pipe into the Sandbag

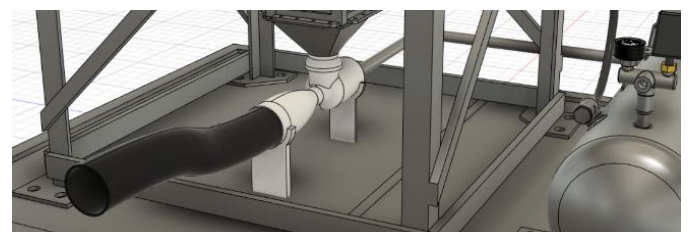

Fig - 6: Venturi pump

**7. CALCULATION**

Calculation of sand hopper and amount of sand required to fill sandbox of multiple engines in single

fill of hopper

Bulk density=  $1.22 \times 10^3 \text{ Kg/m}^3$

Density of silica sand =  $1538 \text{ kg/m}^3$

LOCO sand box capacity

1 sand box =  $14 \text{ ft}^3$

Total 8 sand box in one LOCO =  $112 \text{ ft}^3$

$112 \text{ ft}^3 = 3.17149 \text{ m}^3$

Volume of sand required =  $3.17149 \text{ m}^3$

Mass of sand required =  $3.17149 \times 1538$   
 $= 4877.75 \text{ Kg}$

Total sand required for Filling of all sandboxes of one LOCO is  $4877.75 \text{ kg}$

### 8. STRESS ANALYSIS OF HOPPER

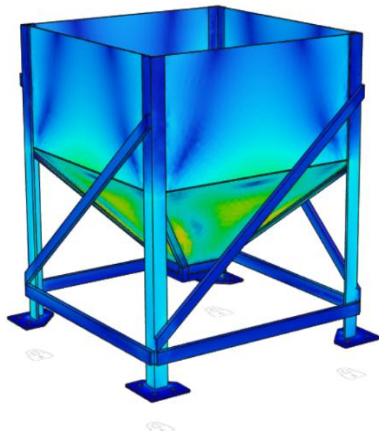

#### Mesh

Average Element Size (% of model size)	
Solids	10
Scale Mesh Size Per Part	No
Average Element Size (absolute value)	-
Element Order	Parabolic
Create Curved Mesh Elements	No
Max. Turn Angle on Curves (Deg.)	60
Max. Adjacent Mesh Size Ratio	1.5
Max. Aspect Ratio	10
Minimum Element Size (% of average size)	20

#### Adaptive Mesh Refinement

Number of Refinement Steps	0
Results Convergence Tolerance (%)	20
Portion of Elements to Refine (%)	10
Results for Baseline Accuracy	Von Mises Stress

#### Steel

Density	$7.85 \times 10^{-6} \text{ kg / mm}^3$
Young's Modulus	210000 MPa
Poisson's Ratio	0.3
Yield Strength	207 MPa
Ultimate Tensile Strength	345 MPa
Thermal Conductivity	$0.056 \text{ W / (mm C)}$
Thermal Expansion Coefficient	$1.2 \times 10^{-5} / \text{C}$
Specific Heat	$480 \text{ J / (kg C)}$

#### Force1

Type	Force
Magnitude	8000 N
X Value	0 N
Y Value	-7991 N
Z Value	-380.5 N
X Angle	0 deg
Y Angle	-45 deg
Z Angle	0 deg
Force Per Entity	No

#### Selected Entities

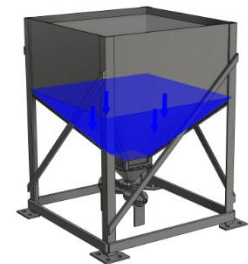

#### Displacement

##### Total

[mm] 0  0.2221

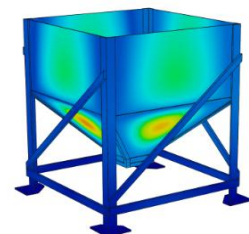

### 9. FUTURE SCOPE

- Heating of sand before discharge to remove moisture content from sand. Wet sand cannot be allowed in sand box as well as it will clog the system.

- Development of Quick release system for sand delivery pipe for easy access and system maintenance
- Venturi pump clog bypass and de clogging mechanism

## 10. CONCLUSIONS

Indian Railways is witnessing Progress every year and the phase has arrived where Indian Railways has taken initiative to electrify its Running Systems and will accomplish its goal by 2030. So we feel effective utilization of resources, reducing wastage of resources and money with proper utilization of manpower will give a boost a to progress. After studying the locomotives, we have come across a design of machine which is capable of meeting future needs machine i.e Sand filling Pneumatic Machine.

### Advantages

- Mobile Machine
- Saves Sand by effectively delivering it to sand box
- Has a Compressor and storage Tank
- Can have energy input (Air Pressure) from Loco & Workshop Pneumatic Pipes as well.
- Requires minimum Maintenance
- Demands no trained manpower

## 11. REFERENCES

- Bedfordshire Silica Sand Study, 2006/2007. Cuesta Consulting Limited.
- Silica Sand: Geology and mineral planning fact sheets for Scotland. BGS 2007 Proposed Extension to existing silica sand operations with progressive restoration, Massingham Quarry, North Lincolnshire. Planning Statements. Sibelco 2009.
- Extension to silica sand extraction operations with progressive restoration:  
  
WBB Minerals. Report by Director of planning and transportation. 5 May 2006.