

Numerical evaluation of diagrid system with other grid system using ANSYS software

Ancy Eldho¹, Anila C Shaju², Inus Paulose³

¹Mtech student, Structural and construction management, MGM CET, Pampakuda P.O, Muvattupuzha, Kerala, India

²Assistant professor, Civil Department, MGM CET, Pampakuda P.O, Muvattupuzha, Kerala, India

³Assistant professor, Civil Department, MGM CET, Pampakuda P.O, Muvattupuzha, Kerala, India

Abstract - Diagrid structures are designed with new geometric layouts. The flexibility and aesthetic appearance make it unique. In this paper comparing four grid systems such as O Grid, Elliptical grid, concentric grid and Forward grid with ANSYS workbench 2021 R2. Also the connection bracings are provided with three shapes such as H, I and C. Analysis with an outrigger with O Grid H, I, C shape is also performed. Analysis is mainly used to determine the seismic performance of models, energy absorption capacity and ductility of the models. After analysis the result obtained that, by comparing with other models O Grid models are between the forward and elliptical bracing systems, and have appropriate load bearing and can absorbed great energy with their axial and flexural behaviour. The utility performance of OG rid with C section shows better result.

modelling and analysis. The dimension of frame is 3000x3000mm. Utility performance of different O Grid outrigger with H, I, C sections is also performed. The dimensions and properties of all the beams and columns of all the specimens are same. The size of different section geometries are shown in Table 1. The different section property are selected from IBC code and the geometries are showed in Table 2.

Table -1: Different Brace Section Geometries.

NAME OF MODEL	COLUMN SECTION	BEAM SECTION	BRACE SECTION
O Grid	IPB 160	IPE180	IPE120
Elliptical grid	IPB 160	IPE180	IPE120
Angular grid	IPB 160	IPE180	IPE120
Forward grid	IPB 160	IPE180	IPE120

Key Words: Diagrid Grid, O Grid, Elliptical bracing system, Grid bracing system, forward bracing seismic response.

1. INTRODUCTION

1.1 General Background

Diagrid constructions have frames arranged in a triangular modular quadrilateral. These triangular members resist vertical and lateral loads. Because there are no elements or columns. A modular framework consists of larger interlocking steels. This system has or does not have vertical components, and since the primary load components are members, they also have lateral support. Ties are commonly used to stabilize a building structure against lateral loading. The main function of the struts is to stabilize the structure and prevent its collapse. Various fastening systems are currently in use. Depending on the shape, the braces are diagonal bracings, X-shaped, K-shaped-shaped, elliptical and O-shaped. In this paper different bracing systems are numerically analysed.

2. NUMERICAL INVESTIGATION USING ANSYS WORKBENCH 2021 R2

Numerical modelling of different grid systems like O Grid, Elliptical grid, concentric grid and Forward grid with different sectional geometries were done using ANSYS 2021 R2 WORKBENCH, a finite element software for mathematical

Table 3 shows the material property of different bracing system. Figure 1 shows a typical example of an O Grid with an I-section geometry, Figure 2 shows a typical example of an elliptical with a C-section geometry, Figure 3 shows a typical example of a concentric grid with H-section geometry and Figure 4 shows the typical example of forward I- section geometry.

Table -2: Section Property.

Section property	IPB 160	IPE180	IPE120
Depth	160	180	120
Width of flange	160mm	91mm	64mm
Thickness of flange	13mm	8mm	6.3mm
Thickness of web	8mm	5.3mm	4.4mm

Table -3: Material Property.

Young's modulus of Steel (GPa)	200
Poisson's ratio of Steel (ν)	0.3
Density of Steel, (kg/m^3)	7850
Yield Strength (MPa)	480

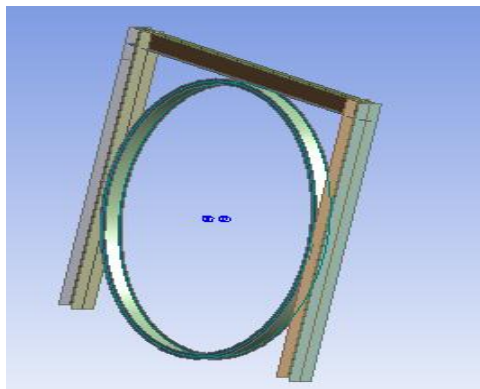

Fig -1: O grid with I-section

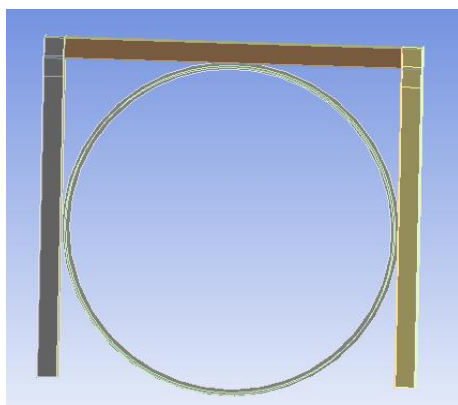

Fig -2: Elliptical grid with C-section

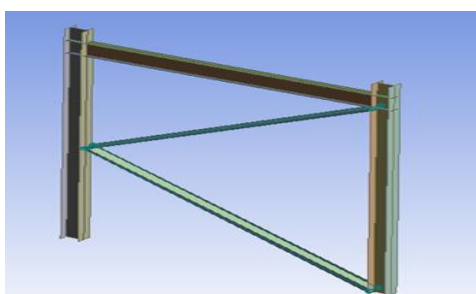

Fig -3: Angular grid with H-section

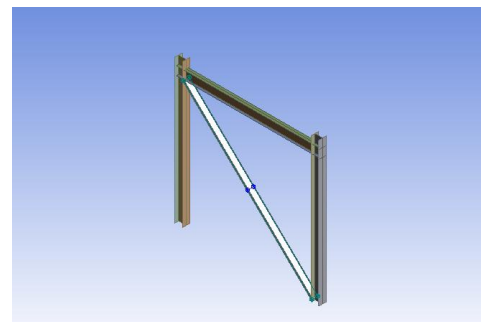

Fig -4: Forward grid with I-section

2.1 Utility performance of O Grid in an outrigger system

An outrigger is constructed with three storey with O Grid. Outrigger with H, I and C sections were modelled. The height of each layer is 3000mm and diameter of O Grid is 2616mm. The length of beam is 9000mm. for first storey there is three O Grids are provided. On the whole structure totally of 9 O Grids are there. Figure 5 shows the modelled view of outrigger with C section geometry.

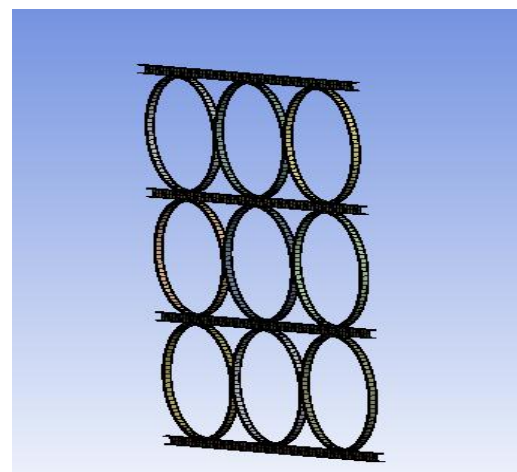

Fig -5: Modelled view of steel with outrigger with C-section

2.2 Loading and boundary conditions

Here a 100mm displacement is given in x-direction. Similar loading conditions is given to twelve models. Also the support condition is fixed. A remote-displacement is also provided. Figure 6 and 7 shows the loading pattern in Angular-I section and in an outrigger geometry.

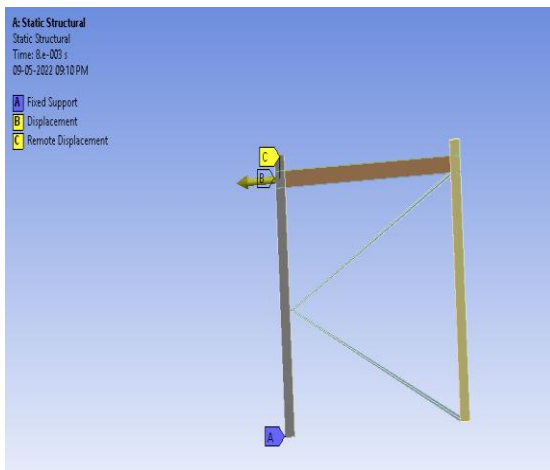

Fig -6 Loading and boundary condition of Angular grid

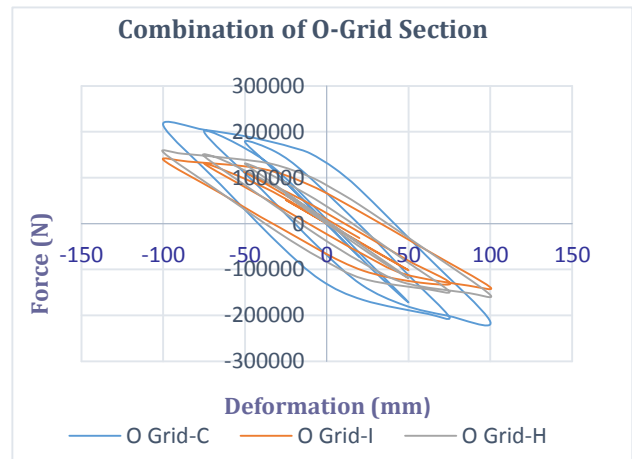

Chart -1: Load-displacement hysteresis curve of O Grid section

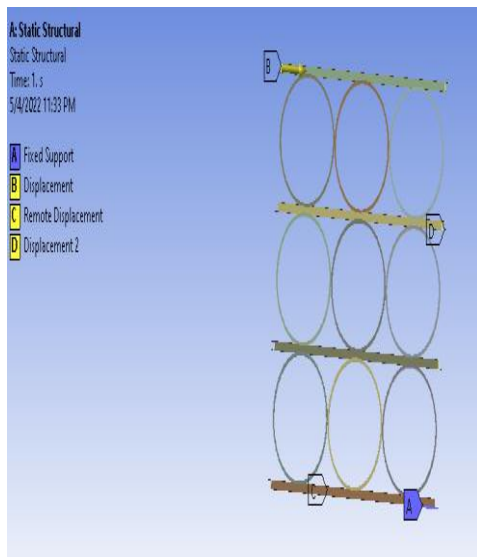

Fig -7 Loading and boundary condition of O Grid in outrigger system

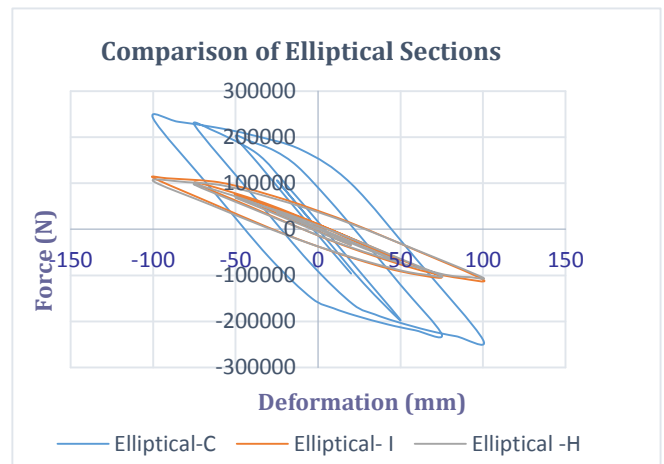

Chart -2: Load-displacement hysteresis curve of elliptical grid section

3. RESULTS AND DISCUSSIONS

The load -displacement hysteresis curves of each model are drawn by comparing the load- deformation values of each model. Chart 1 to chart 4 shows the obtained values.

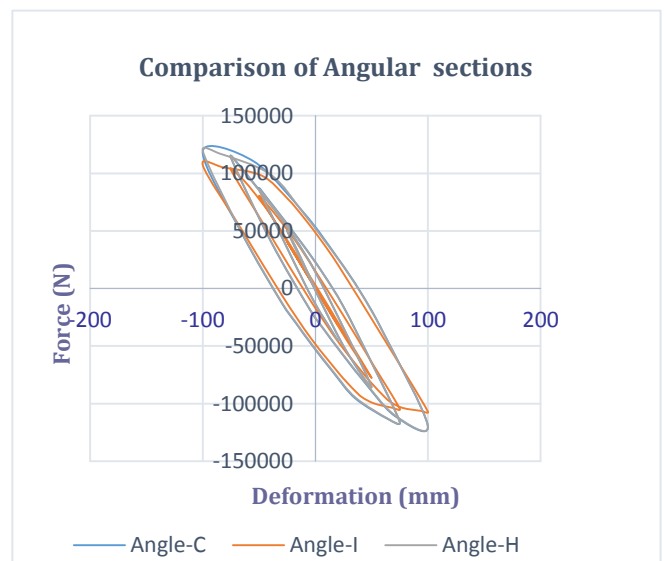

Chart -3: Load-displacement hysteresis curve of angular grid section

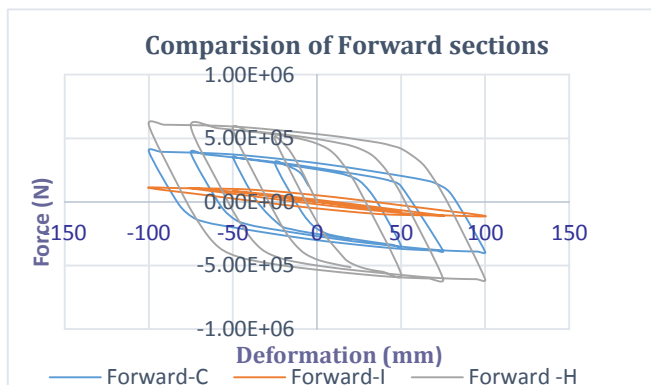

Chart -4: Load-displacement hysteresis curve of forward grid section

The acceptance of different geometries of outrigger will be analyzed using ANSYS software. Table 4 shows the results of an outrigger systems.

Table -4: Results of outrigger system

Name of model	Total deformation (mm)	Equivalent stress (MPa)
Outrigger-I	112.03	653.34
Outrigger-H	112.74	648.37
Outrigger-C	112.44	751.27

Chart 5 shows ductile characteristics of grid systems. From these maximum force value is obtained.

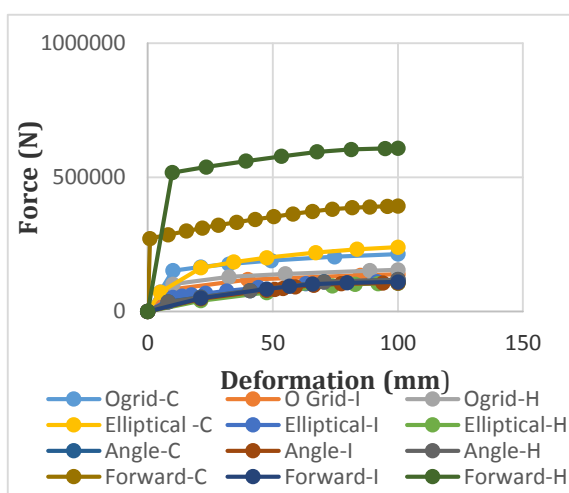

Chart -5: Ductile properties of grid sections

Chart-6 shows the energy absorption capacity of each model.

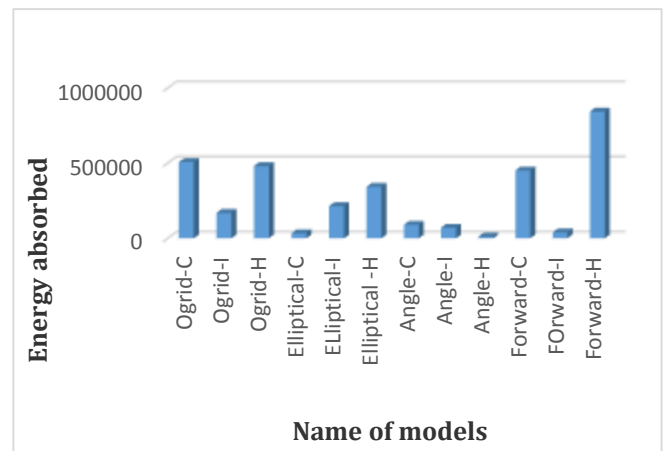

Chart -6: Energy absorption capacity of grid systems

This can be simplified by comparing the maximum force value of outrigger-H, outrigger-I, outrigger-C. Chart 7 shows the maximum force value of different geometries.

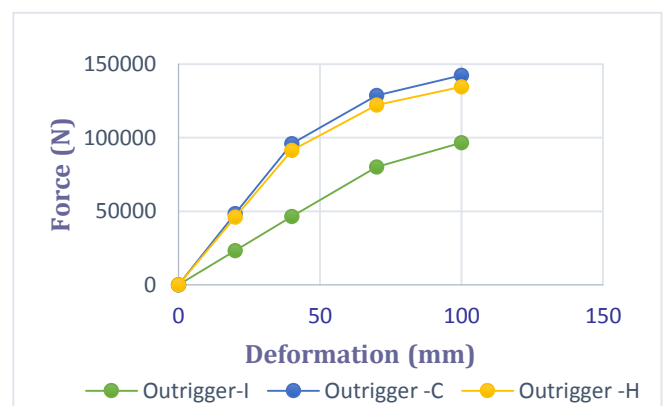

Chart -7: Comparison of outrigger with different geometries

4. CONCLUSIONS

This study was mainly used to compare different types of bracing with different cross section geometries. When analysing, Grid braces are between the forward and elliptical systems, and they have adequate load bearings and can absorb great energy with their axial and flexural behaviour. Unlike other braces, the structure and shape of O Grid braces, can be used in any part of the structure without removing architectural space and architectural form. O grid bracing system has good ductility and stiffness.

The result of analytical study with different bracing section geometry is shown in following conclusions:

- The load-deflection hysteresis curve of twelve models, O Grid with H,I,C-section bracing, elliptical grid with H,I,C-section bracing, angular bracing H,I,C and forward bracing with H,I,C-section .
- The result showed that forward –H section bracing has more ductility and energy absorption capacity, also the one with O Grid-C section bracing shows comparable result.
- The result obtained from the analysis of outrigger shows that Outrigger-C section shows the maximum force and equivalent stress.
- Thus this O Grid-C type of bracing can be effectively used in engineering structures in seismic prone areas which have the ability to withstand lateral loads.

ACKNOWLEDGEMENT

I wish to thank the Management, Principal and Head of Civil Engineering Department of MGM College of Engineering and Technology, affiliated by Kerala Technological University for their support. This paper is based on the work carried out by me (Ancy Eldho), as part of my PG course, under the guidance of Anila. C. Shaju and Inus Paulose (Assistant Professors, MGM College of Engineering and Technology, Muvattupuzha, Kerala). I express my gratitude towards them for valuable guidance.

REFERENCES

- [1] Arshia Keivan, Yunfeng Zhang, "Nonlinear seismic performance of Y-type self-centering steel eccentrically braced frame buildings", Department of Civil and Environmental Engineering, University of Maryland, College Park,USA,2018
- [2] F. Albouye, "Experimental Investigation of New Structural System "OGRID", Department of Civil Engineering, Semnan University, Iran, 2016
- [3] G. Lacidogna, D. Scaramozzino, A. Carpinteri, "Influence of the geometrical shape on the structural behaviour of diagrid tall building under lateral and torque actions", Department of structural Engineering, Corso Duca Degli Abruzzi 24, Torino,Italy,2020.
- [4] Jorge Ruiz-García, Edén Bojorquez, Edgar Coronab. "Seismic behaviour of steel eccentrically braced frames under soft-soil seismic sequences", Soil Dynamics and Earthquake Engineering 115 (2018)
- [5] Maryam Boostani, Omid Rezaifar, Majid Gholhaki, "Experimental investigation of a new lateral bracing system called O Grid under cyclic loading", Department of structural Engineering, Semnan University, Iran,2022.
- [6] Mahathi Heshmati, Alireza Khatami, Hamzeh Shakib, "Seismic performance assessment of tubular diagrid structures with varying angles in tall steel buildings", Department of civil and Environmental Engineering, Tarbiat Modares University, Iran,2020.
- [7] Qingxuan Shi, Yihui Ying, Bin Wang, "Experimental investigation on the seismic performance of concrete filled steel tubular joints in diagrid structures", College of civil engineering, Xi'an University of Architecture & technology, Xi'an 710055, China,2020.