

Solar based IOT controlled EV

Mr. Vinay Kumar .H, K Nagashree, L Neeraja, Goutam Patil, Shabbeer M

¹BE Assistant Professor, Dep. Of Electrical and electronics Engineering, RYM Engineering College, Ballari, Karnataka, India.

²³⁴⁵BE Student, Dep. of Electrical and electronics Engineering, RYM Engineering College, Ballari, Karnataka, India.

Abstract -The automotive industry has become one of the most important world-wide industries, not only at economic level, but also in terms of research and development. Increasingly, there are more technological elements that are being introduced on the vehicle towards the improvement of both passengers and pedestrians' safety. In addition, there is a greater number of vehicles on the roads, which allows for us to move quickly and comfortably. However, this has led to a dramatic increase in air pollution levels in urban environments (i.e., pollutants, such as PM, nitrogen oxides (NOX), CO, sulphur dioxide (SO₂), etc.). In addition, and according to a report by the transport sector is responsible for nearly 28% of the total carbon dioxide (CO₂) emissions, while the road transport is accountable for over 70% of the transport sector emission. Therefore, the authorities of most developed countries are encouraging the use of Electric vehicle (EVs) to avoid the concentration of air pollutants, CO₂, as well as other greenhouse gases. So electrical vehicle is best option over this all issues. But charging of electrical vehicle is again new task. We are implementing a self- charging system in this project for solve this charging issue

1. INTRODUCTION

The project is focused on the design of an electric driven vehicle that can regenerate power using solar energy technology. If this type of vehicle became a standard commercial vehicle, the demand for fuel would decrease substantially. Creation of feasible alternative energy vehicles will have a positive impact on the environment. Since combustion engines never achieve complete combustion, resulting extraneous gases add to the problem of global warming. Electric motors produce zero emissions; therefore, the application of urban electric driven vehicle will dramatically decrease the amount carbon dioxide (CO₂) contributing to global warming. One other environmental factor should be considered when weighing the switch from combustion engines to electric motors. We are implementing with all inbuilt electrical vehicle function like direction control, speed control and charging of electrical vehicle.

LITERATURE SURVEY

- ② Takadir S Pin jar, Assistant Professor, Department of Electrical Engineering, Trinity College of Engineering and Research,
- In this paper, the solar charging station that gives the electricity to charge the battery. The charging station has integrated battery storage that allows for off-grid operation. The DC charging uses the DC power from the photovoltaic panels directly for charging the vehicles battery without the utilization of an AC charging adapter. This paper presenting the solar charging station for sort of electric vehicles, which is generally used to avoid use of nonrenewable source of energy to charge for all intents and purposes electric vehicles, which is fairly significant. This study develops a model that really combines the solar power station and EVs to mostly reduce pollutants emission from the power generation and transportation sector in a suitable way.
- ② Chinmay A. Dandekar (Electrical Department, VIVA Institute of Technology, India) VIVA Institute of Technology 9th National Conference on Role of Engineers in Nation.
- This paper gives you a basic overview about designing and implementing the process of solar electric vehicle. A solar car does not use any combustion thus it is free from any cause for global warming. This paper proposes a method to design multi-seated solar car different from the one available in market, in a cheaper way. The most essential equipment for building a solar vehicle are the solar panels. The photovoltaic panels of 250 W are connected as a photovoltaic array to charge a lithium-ion battery bank of 48 V and 78 Ah during the day hours. With the help of this technology, we aim to make solar energy powered car in our project
- ② Tejas Sonawane, Sinhgad Academy of Engineering, Kondhwa, Pune, Maharashtra, Sonawane Tejas et al International Journal of Advance Research, Ideas and Innovations in Technology.

2 This project focuses on system electric vehicle charging station. We make use of solar power as it is totally green energy. Nowadays the petrol price has increased and fuels are costlier as they are high in demand, so it is good to go for solar power as green energy has no adverse effect on the environment. Electric energy can be created by solar energy or by using other options

2. METHODOLOG

... DC-DC Converter can be applied one of them on a power generation system with a source of solar panels. Some of the objectives of implementing DC-DC converter on solar panel electrical networks such as: optimizing the output of solar panel power, maintaining the output voltage of solar panels at a certain value range, or for other system applications [4,5]. Some examples of DC-DC Converter are Buck Converter, Boost Converter, Buck-Boost Converter, SEPIC Converter, CUK Converter, ZETA Converter, and other types of DC-DC Converter [6]. ...

... Single Ended Primary Inductance Converter (SEPIC) is a type of converter with almost the same capabilities as Buck- Boost Converter or CUK Converter. This type of converter is used to supply load modules, which tend to have a higher voltage rating [5]. Basically, the mathematical equation that applies to SEPIC Converter is also almost the same as the mathematical equation that applies to Buck-Boost Converter and CUK Converter. ...

4.1 Design Structure and Hardware Used

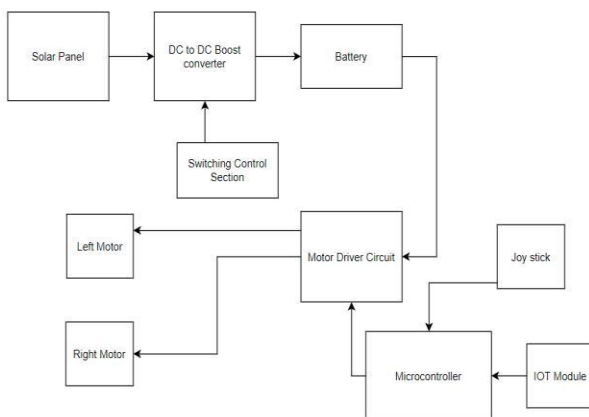

Figure.1 Block Diagram of solar based iot controlled EV

Explanation of Block Diagram

The project is focused on the design of an electric driven vehicle that can regenerate power using solar energy technology. If this type of vehicle became a standard commercial vehicle, the demand for fuel would decrease substantially. Creation of feasible alternative energy vehicles will have a positive impact on the environment.

Since combustion engines never achieve complete combustion, resulting extraneous gases add to the problem of global warming. Electric motors produce zero emissions; therefore, the application of urban electric driven vehicle will dramatically decrease the amount carbon dioxide (CO₂) contributing to global warming. One other environmental factor should be considered when weighing the switch from combustion engines to electric motors. We are implementing with all inbuilt electrical vehicle function like direction control, speed control and charging of electrical vehicle.

4.2 ATmega16 IC (Arduino UNO):



Fig-2: Arduino UNO

Fig 2. shows the Arduino UNO board. It is basically a micro-controller kit that is used to get data from peripheral devices (sensors, motors, etc.). The Arduino UNO Micro-controller board is based on the ATmega328P IC. The ATmega328P is good platform for robotics application which makes robot to extinguish fire in real time. Arduino UNO board consist the sets of digital and analog pins that may act as an interface to various expansion boards and other circuits. It contains everything needed to support the microcontroller.

4.3 Iot Node Mcu:



Fig-3: IOT Esp8266 Node MCU

Node MCU is an excellent hardware, which provides just enough versatility for us to do a majority of our developments. It is Arduino compatible, has a Wi-Fi on board and has enough kick to power our IOT devices. Whether connecting to gateway or connecting to our cloud solutions.

"Node MCU is an open source IOT platform. It includes firmware which runs on the ESP8266 Wi-Fi So C from Express if Systems, and hardware which is based on the

ESP-12 module. The term "Node MCU" by default refers to the firmware rather than the development kits. The firmware uses the Lau scripting language."

4.4 Joysticks:

The direction of the robot is controlled using joysticks. The terminals of joysticks is connected to ADC pins of micro controller. Joysticks are usually the potentiometer, the potential variations is given as an input to micro controller and robot is operated accordingly.



Fig-4: Joysticks

4.5 Motor Drivers:

5 Node MCU is an excellent hardware, which provides just enough versatility for us to do a majority of our developments. It is Arduino compatible, has a Wi-Fi on board and has enough kick to power our IOT devices. Whether connecting to gateway or connecting to our cloud solutions.

"Node MCU is an open source IOT platform. It includes firmware which runs on the ESP8266 Wi-Fi So C from Expressif Systems, and hardware which is based on the ESP-12 module. The term "Node MCU" by default refers to the firmware rather than the development kits. The firmware uses the Lau scripting language."

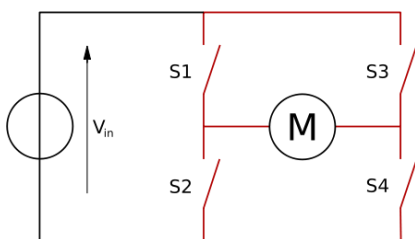

Fig-5: Basic diagram of H-bridge

In the given diagram, the arrow on the left points to the higher potential side of the input voltage of the circuit. Now if the switches S1 & S4 are kept in a closed position while the switches S2 & S3 are kept in an open position meaning that the circuit gets shorted across the switches S1 & S4. This creates a path for the current to flow, starting from the V input to switch S1 to the motor, then to switch

S4 and then the exiting from the circuit. This flow of the current would make the motor turn in one direction. The direction of motion of the motor can be clockwise or anti-clockwise; this is because the rotation of the motor depends upon the connection of the terminals of the motor with the switches.

For simplicity, let's assume that in this condition the motor rotates in a clockwise direction.

Now, when S3 and S2 are closed then and S1 and S4 are kept open then the current flows from the other direction and the motor will now definitely rotates in counter-clockwise direction

5. EXPECTED RESULT

- The solar will generate the energy from sun light
- Boost converter will boost up the solar generated energy.
- The energy will get store in Battery
- User will able to change vehicle speed
- User will able to change direction of vehicle
- We Can add multi source in future
- We can add one more battery backup in future
- We Can add alert option in future

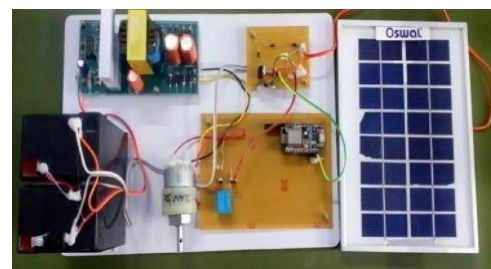

Figure: solar powered IOT control EV

Advantages:

1. Easy to use
2. Cost effective
3. Renewable energy based
4. Remote controlling

Applications:

1. Farming
2. Industry
3. Cart
4. Golf car
5. Dealivery cart
6. Shopping cart

- T.Balamurugan #1, Dr.S.Manoharan *2 # Research Scholar, Department of Electrical and Electronics Engineering, Karpagam University, Coimbatore.
- Gangesh Shukla 4B.Tech Student, Dept. of EE, Parul University, Vadodara, Gujarat, India International Research Journal of Engineering and Technology (IRJET).

6. Acknowledgement:

We as the authors would like to extend a special vote of thanks to our guide Prof. Vinay Kumar.H for their valuable guidance and suggestions to improve this paper without which it would have been a very difficult task..

7. CONCLUSION

When electrons flow through such a circuit, they generate electricity. Multiple cells make up a solar panel, and multiple panels (modules) can be wired together to form a solar array. The more panels you can deploy, the more energy you can expect to generate. This project, microcontroller-based energy flow control designed for effectively and efficiently use of energy source in a hybrid energy generation system. The main purpose of our project is to provide power supply to vehicle using solar panel. User will be able to drive the vehicle using smart phone IOT app and using Joy stick control.

8. REFERENCES

- Takadir S Pinjar, Assistant Professor, Department of Electrical Engineering, Trinity College of Engineering and Research,
- Chinmay A. Dandekar (Electrical Department, VIVA Institute of Technology, India) VIVA Institute of Technology 9th National Conference on Role of Engineers in Nation.
- Tejas Sonawane, Sinhgad Academy of Engineering, Kondhwa, Pune, Maharashtra, Sonawane Tejas et al International Journal of Advance Research, Ideas and Innovations in Technology.
- Yogesh Sunil Wamborikar, Abhay Sinha, Proceedings of the World Congress on Engineering and Computer Science.