

A Comparative Study between Different Types of Multilevel Inverter

Titas Bhaumik¹, Sumangal Bhaumik², Surajit Paul³, Snehashis Mitra⁴

¹ Assistant Professor, Dept. of EE, Abacus Institute of Engineering & Management, India

² Dept of Applied Physics, The University of Calcutta, India

³ B. Tech Student, Dept. of EE, Abacus Institute of Engineering & Management, India

⁴ B. Tech Student, Dept. of EE, MCKV Institute of Engineering, India

Abstract - This paper compares between four different topologies of cascaded H-bridge multilevel inverter. Inverter can be defined as a power electronic device which can convert dc to ac at specified output voltage and frequency. Multilevel inverters are the preferred choice of industry for application in high voltage and high power. The basic advantage of a multilevel inverter is that it can give high power at the output while working under medium voltage source. It does so with the help of multiple dc sources at the input. The main merits of the paper are Comparative Study of Different Types of Multilevel Inverter and also study on minimizing the total harmonic distortion which will help the designer to design an appropriate multilevel inverter.

Key Words: Multilevel, Inverter, Total Harmonic Distortion, IGBT, Bridge Connection

1. INTRODUCTION

An inverter is a power electronic device that converts DC power into AC power at desired output voltage and frequency [1]. Generally, the two-level inverter is the one that is used to convert dc into ac. Two-level inverter produces output voltage or current utilizing two different levels. For example, if V is given as an input then the inverter will provide $+V/2$ and $-V/2$ at the output. [1]

Now a day the concept of multilevel inverter is very popular and it can be termed as a modification of two-level inverter. In multilevel inverter we deal with more than two level voltages in order to create a smoother stepped output waveform. The output waveform obtained in this case has lower dv/dt and also lower harmonic distortions. Multilevel inverters generate a smooth sinusoidal waveform from several DC voltage levels at its input. The input side of a multilevel inverter have several DC sources, which can be obtained from batteries or a renewable energy source as well. It has a lot of application in wide industries. There are several topologies of multilevel inverters which are available, but the main difference is their mechanism of switching and the input source voltage. Three most commonly used multilevel inverter topologies are:

- Cascaded H-bridge multilevel inverter.
- Diode clamped multilevel inverter.

- Flying capacitor multilevel inverter.[1][2]

2. CONCEPT OF MULTILEVEL INVERTER

The origin of multilevel inverter idea is derived from the power semiconductors array design, which uses multiple input sources. In case of inverter, the sources are DC which produces AC output waveforms of multiple step voltage with variable amplitude, frequency and phase. The multilevel converters have a minimum of three voltage level to create smoother output waveform, lower dv/dt and lower harmonic distortions. The major difference between two level sources and multilevel is two levels can produce only two levels of voltage but multilevel could produce unlimited voltage levels, although multilevel inverter needs a complicated switching circuit rather than two level converters.[3]

The quality of power converters is judged by the quality of its V/I waveforms. The measurement of harmonic spectra can be expressed in terms of total harmonic distortion (THD). The lower the THD value, the better its power quality. There is a similarity between level three and level two inverters, but in three level inverters, clamping diodes are used in between the two valves and are connected to the neutral between two capacitors. Three level inverter each phase leg generates the three voltage levels $(+Vdc, 0, -Vdc)$. [4][5]

3. CASCADED H-BRIDGE MULTILEVEL INVERTER

The cascaded H-Bridge multilevel inverter is the most advanced and important method of power electronic converters that analyses output voltage with number of dc sources as inputs. As compared to neutral point clamped multilevel inverter and flying capacitor multilevel inverter, the cascaded H-Bridge multilevel inverters require less number of components. It also produces high quality output voltage which is closer to sine wave. To verify the operation and to check the harmonic of the cascaded H-bridge multilevel inverter using the Sinusoidal Pulse Width Modulation (SPWM) technique, MATLAB software is used for the simulation. By increasing the number of output levels the Total Harmonic Distortion (THD) in output voltage can be reduced. [4][6]

Four different cascaded H-bridge multilevel inverter are described below:

3.1 Single Phase 3rd Level Cascaded H-Bridge Multilevel Inverter

Fig. 1 shows Single phase Three level Cascaded H-Bridge inverter consisting of single isolated DC source ($V=100$) four IGBT switches & load ($R=10$). The result of output voltage waveform of three levels multilevel inverter is shown in fig. 2 consists of three levels $0, +V_{dc}, -V_{dc}$. [7]

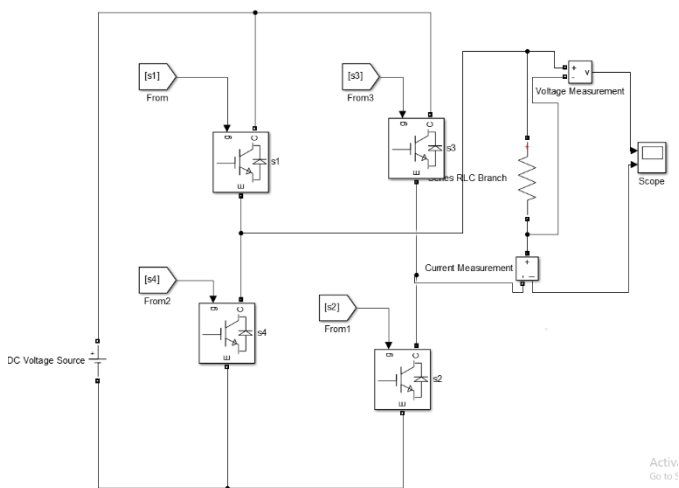

Fig. 1: Circuit Diagram of 3rd Level

Modes of Operation

Different modes of operation of three levels cascaded H-Bridge multilevel inverter are explained below:

Mode 1

In this mode of operation of three level cascaded H-Bridge inverter switches s_1 & s_3 are turned on & no source is connected to the load. Zero output voltage across the load is obtained.

Mode 2

In this mode of operation of three level cascaded H-Bridge inverter, switches s_1 & s_2 are turned on. Output voltage obtained across the load is $+V_{dc}$.

Mode 3

In this mode of operation of three level cascaded H-Bridge inverter switches s_3 & s_4 are turned on. Output voltage obtained across the load is $-V_{dc}$.

Table 1: Switching Operation of Single Phase Three Level Cascaded H- Bridge Inverter

Mode	Switch 1	Switch 2	Switch 3	Switch 4
1	1	0	1	0
2	1	1	0	0
3	0	0	1	1

Result

Fig. 2 presents the simulation results obtained for the defined output voltage waveform and Total Harmonic Distortion (THD).

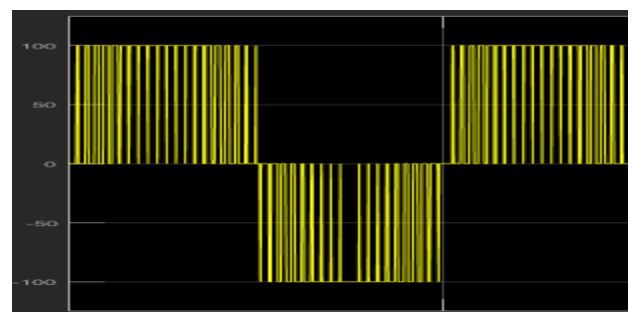

Fig. 2: Output Waveform of 3rd Level

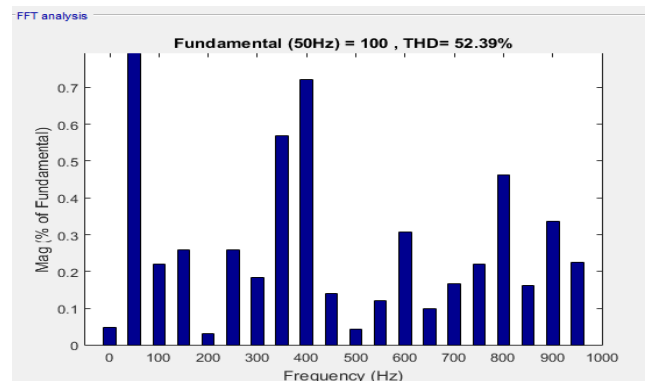

Fig. 3: THD of 3rd Level

3.2 Single Phase 5th Level Cascaded H-Bridge Multilevel Inverter

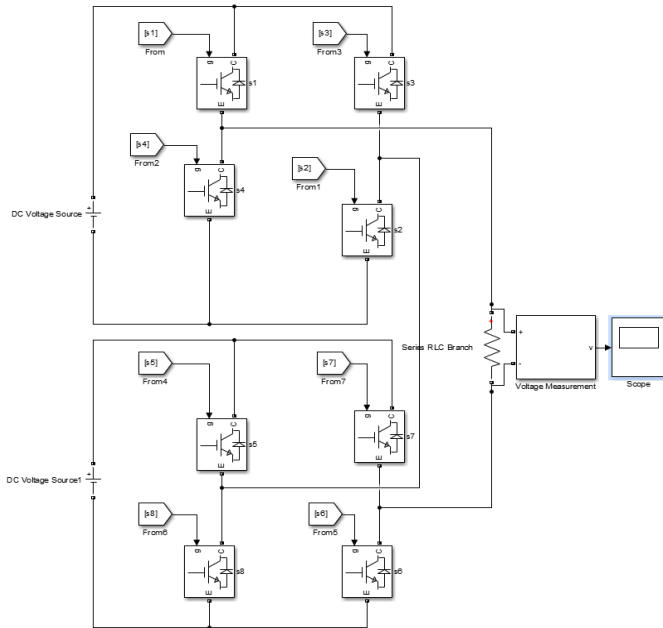

Fig. 4: Circuit Diagram of 5th Level

Modes of Operation

The operation of five levels of cascaded H bridge multilevel inverter is explained below:

Mode1

In this mode of operation of single phase five level cascaded H-Bridge multilevel inverter, S_1, S_3, S_5 and S_7 are turned on without connecting source to the load. The output voltage across the load obtained is zero.

Mode2

In this mode of operation of single phase five level cascaded H-Bridge multilevel inverter S_1, S_2, S_5 and S_7 are turned on. The output voltage across the load obtained is $+V_{dc}$.

Mode3

In this mode of operation single phase five level cascaded H-Bridge multilevel inverter S_1, S_2, S_5 and S_6 are turned on. The output voltage across the load obtained is $+2V_{dc}$.

Mode4

In this mode of operation single phase five levels H-Bridge cascaded multilevel inverter S_1, S_3, S_7 and S_8 are turned on. The output voltage across the load obtained is $-V_{dc}$.

Mode5

In this mode of operation single phase five levels H-Bridge cascaded multilevel inverter S_3, S_4, S_7 and S_8 are turned on. The output voltage across the load obtained is $-2V_{dc}$. [8]

Table 2. Switching Operation of Single Phase 5th Level Cascaded H- Bridge Inverter

Mode	S1	S2	S3	S4	S5	S6	S7	S8
1	1	0	1	0	1	0	1	0
2	1	1	0	0	1	0	1	0
3	1	1	0	0	1	1	0	0
4	1	0	1	0	0	0	1	1
5	0	0	1	1	0	0	1	1

Result

Fig. 4 present the simulation results obtain for the output voltage waveform and also Total Harmonic Distortion (THD).

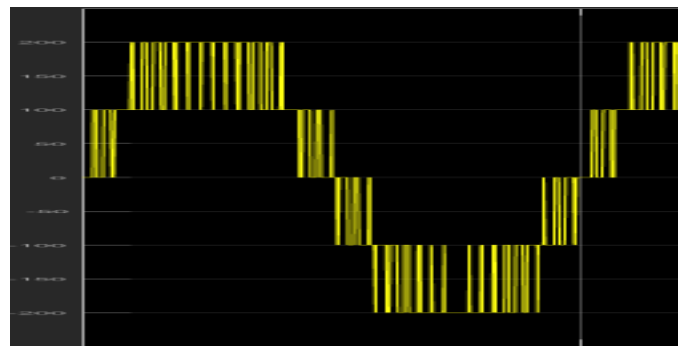

Fig. 5: Output waveform of 5th level

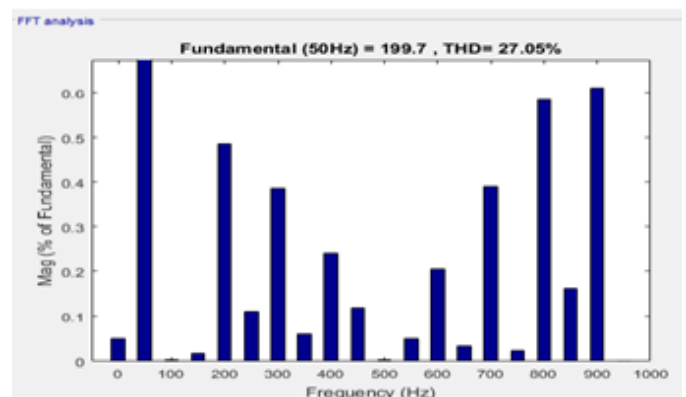

Fig. 6: THD 5th Level

3.3 Single Phase 7th Level Cascaded H-Bridge Multilevel Inverter

Fig. 5 shows single phase cascaded H- bridge multilevel inverter consisting of three H-bridges with 12 IGBT switches, three dc source ($V=100$) and R load ($R=10$). In this configuration twelve IGBT switches ($S_1, S_2, S_3, S_4, S_5, S_6, S_7, S_8, S_9, S_{10}, S_{11}, S_{12}$) are used. Three H-bridges are connected in series to generate seven level output voltage. The result of output voltage waveform of seven levels multilevel inverter is shown in Fig. 6 which consists of seven levels $0, +3V_{dc}, +2V_{dc}, +V_{dc}, -3V_{dc}, -2V_{dc}, -V_{dc}$. [9]

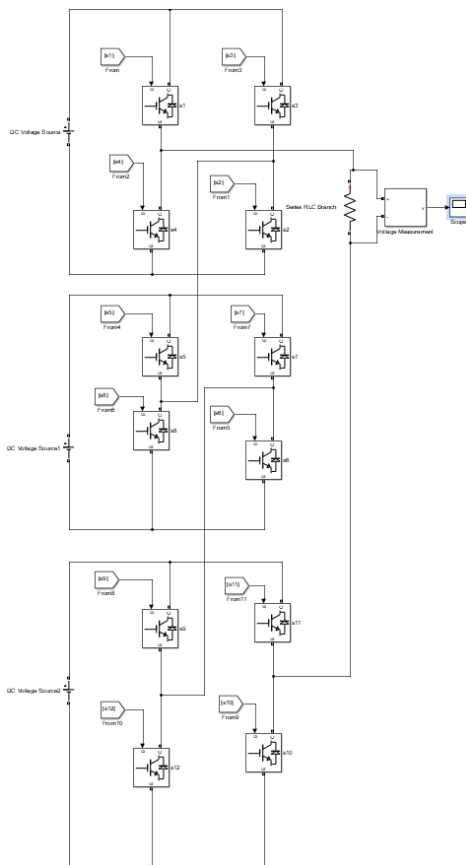

Fig. 7: Circuit diagram of 7th level

Modes of Operation

The working operation of cascaded H-bridge seven levels multilevel is explained below:

Mode1

In this mode of operation, single phase seven level cascaded H-Bridge multilevel inverter S_1, S_3, S_5, S_7, S_9 and S_{11} are turned on without connecting source to the load. The output voltage across the load obtained is zero.

Mode2

In this mode of operation single phase seven level cascaded H-Bridge multilevel inverter S_1, S_2, S_5, S_6, S_9 and S_{10} are turned on. The output voltage across the load obtained is $+3V_{dc}$.

Mode3

In this mode of operation single phase seven level cascaded H-Bridge multilevel inverter S_1, S_2, S_5, S_6, S_9 and S_{11} are turned on. The output voltage across the load obtained is $+2V_{dc}$.

Mode4

In this mode of operation single phase seven levels H-Bridge cascaded multilevel inverter S_1, S_2, S_5, S_7, S_9 and S_{11} are turned on. The output voltage across the load obtained is $2V_{dc}$.

Mode5

In this mode of operation single phase seven levels H-Bridge cascaded multilevel inverter $S_3, S_4, S_7, S_8, S_{11}$ and S_{12} are turned on. The output voltage across the load obtained is $-3V_{dc}$.

Mode6

In this mode of operation single phase seven levels H-Bridge cascaded multilevel inverter S_3, S_4, S_7, S_8, S_9 and S_{11} are turned on. The output voltage across the load obtained is $2V_{dc}$.

Mode7

In this mode of operation single phase seven levels H-Bridge cascaded multilevel inverter S_3, S_4, S_5, S_7, S_9 and S_{11} are turned on. The output voltage across the load obtained is $-V_{dc}$. [10][11]

Table 3. Switching Operation of Single Phase

Mo de	S 1	S 2	S 3	S 4	S 5	S 6	S 7	S 8	S 9	S1 0	S1 1	S1 2
1	1	0	1	0	1	0	1	0	1	0	1	0
2	1	1	0	0	1	1	0	0	1	0	1	0
3	1	1	0	0	1	1	0	0	1	0	1	0
4	1	1	0	0	1	0	1	0	1	0	1	0
5	0	0	1	1	0	0	1	1	0	0	1	1
6	0	0	1	1	0	0	1	1	1	0	1	0
7	0	0	1	1	1	0	1	0	1	0	1	0

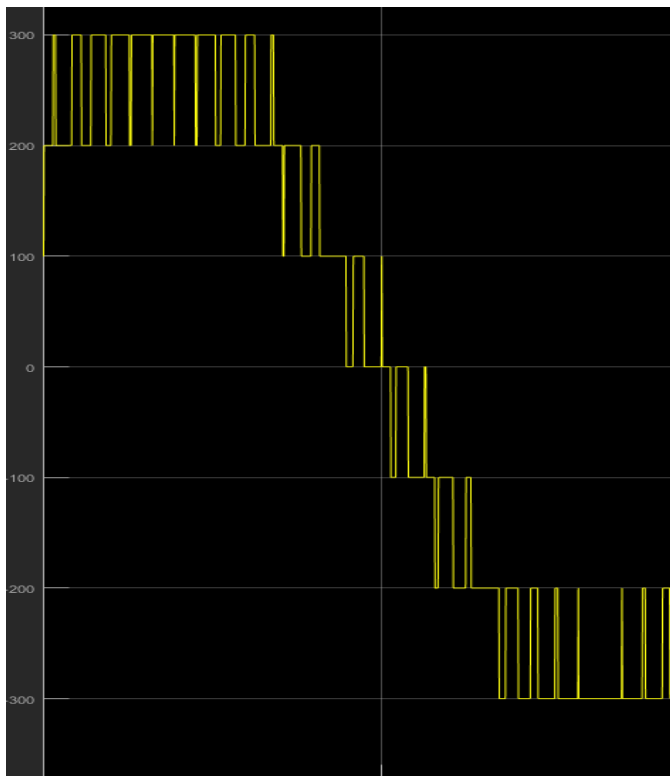

Fig. 8: Output waveform of 7th level

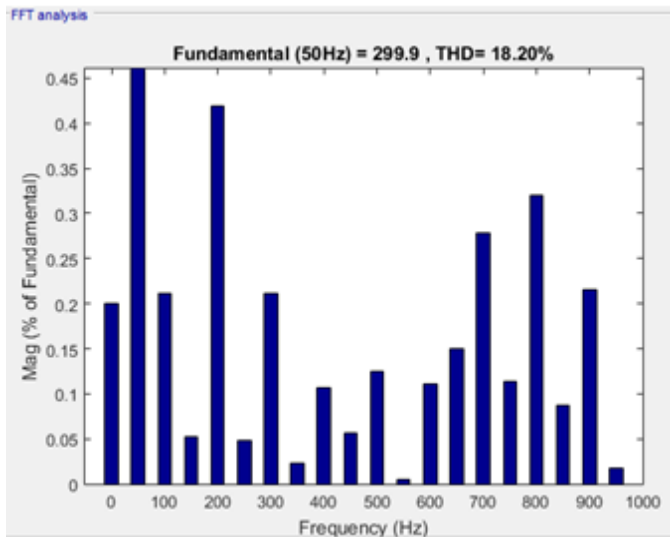

Fig. 9: THD of 7th level

3.4 Single Phase 9th Level Cascaded H-Bridge Multilevel Inverter

Fig. 7 shows single phase cascaded H- bridge multilevel inverter consisting of three H-bridges with 16 IGBT switches, three dc sources ($V=100$) and R load ($R=10$). In this configuration, sixteen IGBT switches are ($S_1, S_2, S_3, S_4, S_5, S_6, S_7, S_8, S_9, S_{10}, S_{11}, S_{12}, S_{13}, S_{14}, S_{15}, S_{16}$) used. Four H-bridges are connected in series to generate nine levels of output

voltage. The result of output voltage waveform of this kind of multilevel inverter is shown in Fig. 8 which consists of nine levels $0, +4V_{dc}, +3V_{dc}, +2V_{dc}, +V_{dc}, -4V_{dc}, -3V_{dc}, -2V_{dc}, -V_{dc}$ [12][13]

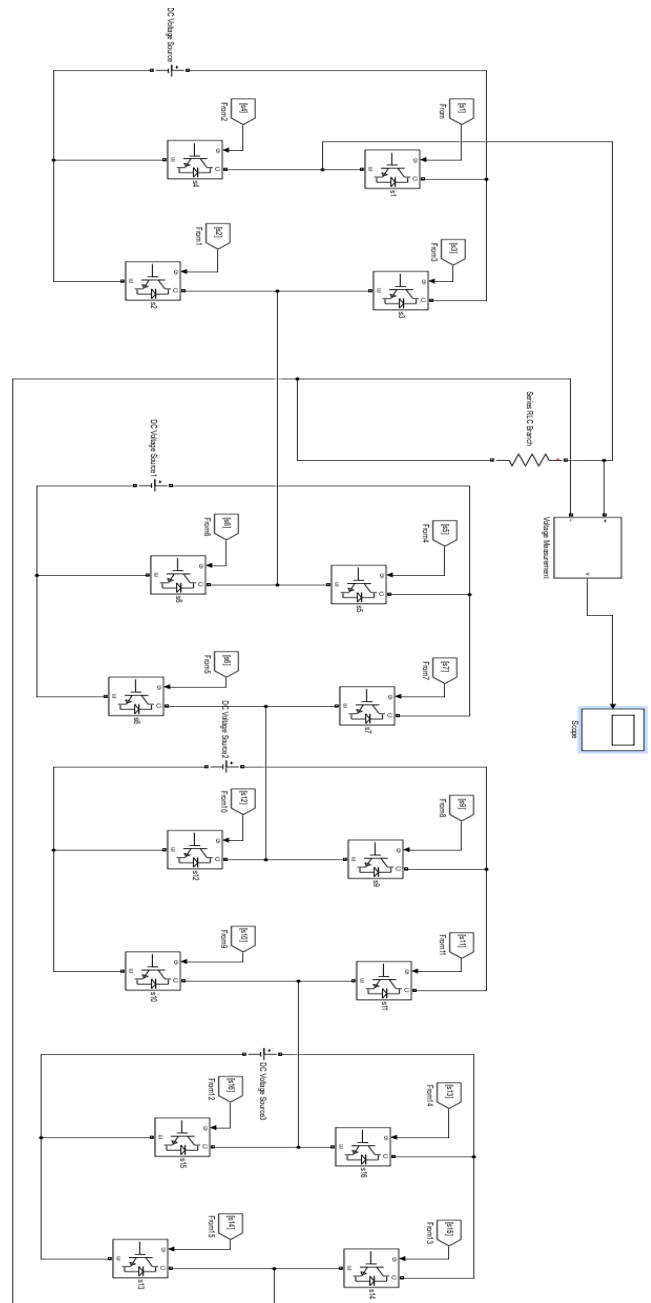

Fig. 10: Circuit diagram of 9th level Inverter

The working operation of cascaded H-bridge nine levels multilevel is explained below:

Mode1

In this mode of operation single phase nine level cascaded H-Bridge multilevel inverter $S_1, S_3, S_5, S_7, S_9, S_{11}$ and S_{13}, S_{15}

are turned on without connecting source to the load. The output voltage across the load obtained is zero.

Mode2

In this mode of operation single phase nine level cascaded H-Bridge multilevel inverter $s_1, s_2, s_5, s_6, s_9, s_{10}$ and s_{13} and s_{14} are turned on. The output voltage across the load obtained is $+4V_{dc}$.

Mode3

In this mode of operation single phase nine level cascaded H-Bridge multilevel inverter $s_1, s_2, s_5, s_6, s_9, s_{10}$ and s_{13}, s_{15} are turned on. The output voltage across the load obtained is $+3V_{dc}$.

Mode4

In this mode of operation single phase nine levels H-Bridge cascaded multilevel inverter $s_1, s_2, s_5, s_6, s_9, s_{11}$ and s_{13}, s_{15} are turned on. The output voltage across the load obtained is $+2V_{dc}$.

Mode5

In this mode of operation single phase nine levels H-Bridge cascaded multilevel inverter $s_1, s_2, s_5, s_7, s_9, s_{11}, s_{13}$ and s_{15} are turned on. The output voltage across the load obtained is $+V_{dc}$.

Mode6

In this mode of operation single phase nine levels H-Bridge cascaded multilevel inverter $s_3, s_4, s_7, s_8, s_{11}, s_{12}, s_{15}$ and s_{16} are turned on. The output voltage across the load obtained is $-4V_{dc}$.

Mode7

In this mode of operation single phase nine levels H-Bridge cascaded multilevel inverter $s_3, s_4, s_7, s_8, s_{11}, s_{12}, s_{13}$ and s_{15} are turned on. The output voltage across the load obtained is $-3V_{dc}$.

Mode8

In this mode of operation single phase nine levels H-Bridge cascaded multilevel inverter $s_3, s_4, s_7, s_8, s_9, s_{11}, s_{13}$ and s_{15} are turned on. The output voltage across the load obtained is $-2V_{dc}$.

Mode9

In this mode of operation single phase nine levels H-Bridge cascaded multilevel inverter $s_3, s_4, s_5, s_7, s_9, s_{11}, s_{13}$ and s_{15} are turned on. The output voltage across the load obtained is $-V_{dc}$. [14][15][16]

Table 4: Switching table of single phase ninth level cascaded H- Bridge Inverter

Mode	S1	S2	S3	S4	S5	S6	S7	S8	S9	S10	S11	S12	S13	S14	S15	S16
1	1	0	1	0	1	0	1	0	1	0	1	0	1	0	1	0
2	1	1	0	0	1	1	0	0	1	1	0	0	1	1	0	0
3	1	1	0	0	1	1	0	0	1	1	0	0	1	0	1	0
4	1	1	0	0	1	1	0	0	1	0	1	0	1	0	1	0
5	1	1	0	0	1	0	1	0	1	0	1	0	1	0	1	0
6	0	0	1	1	0	0	1	1	0	0	1	1	0	0	1	1
7	0	0	1	1	0	0	1	1	0	0	1	1	1	0	1	0
8	0	0	1	1	0	0	1	1	1	0	1	0	1	0	1	0
9	0	0	1	1	1	0	1	0	1	0	1	0	1	0	1	0

Result

Fig. 8 present the simulation results obtain for the output voltage waveform and also Total Harmonic Distortion (THD).

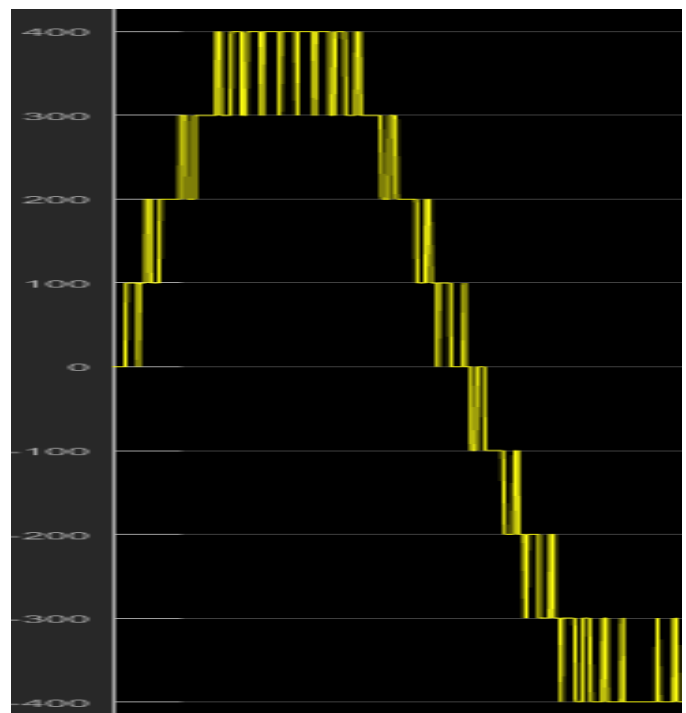

Fig. 11: Output waveform 9th level

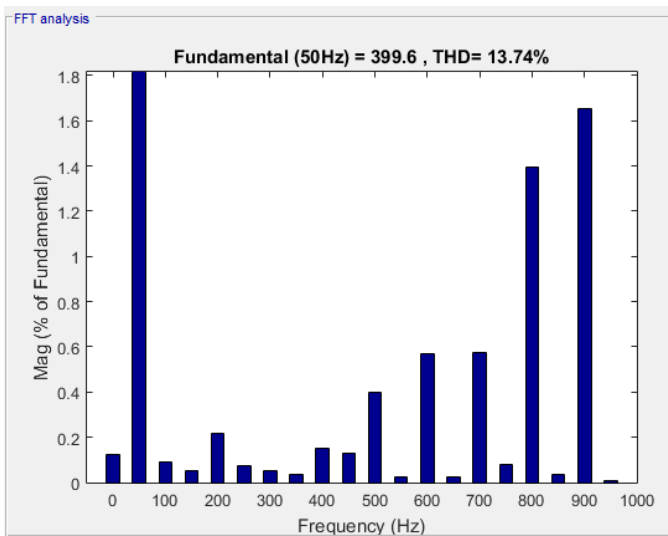

Fig. 12: THD of 9th level

CONCLUSION

In the above, a comparison between different level of multilevel inverter, such as the three, five, seven and nine level has been discussed. The comparison of this inverter was based on the criteria of output voltage, lower THD and to reduce the cost of the inverter as per IEEE 519 standard. The discussion results in depicting the pros and cons of various types of multilevel inverter, which certainly gives the idea for future works on the topic. This discussion will also help the industrial sector in building an efficient inverter technology which might help the industrial sector as well as the households. Also, the advancement in developing efficient inverter might also help in HVDC transmission technology and therefore resulting in efficient transmission, lower transmission loss and better power quality.

4. REFERENCES

- [1] Titus Bhaumik and Dipu Mistry, "UPS with Dual Power Supply for Household Loads' Energy Conservation," IRJET, Volume: 06 Issue: 04, Apr 2019, pp 3846-3849
- [2] S. Bhaumik, B. Mondal, J. Bera, "Low-Voltage Hardware-in-Loop Test Model Using Real-Time Digital Simulator for Single-Phase Converter", vol 537. Springer, Singapore. https://doi.org/10.1007/978-981-13-3450-4_10
- [3] Mohammad Tayyab, Adil Sarwar, Md Reyaz Hussan, Shadab Murshid, Mohd Tariq, Basem Alamri, "A novel voltage boosting switched-capacitor 19-level inverter with reduced component count", International Journal of Circuit Theory and Applications, 10.1002/cta.3235, 50, 6, (2128-2149), (2022). R. Nicole.
- [4] Shahab Sajedi, Michael Farrell, Malabika Basu, "DC side and AC side cascaded multilevel inverter topologies: A comparative study due to variation in design features", International Journal of Electrical Power & Energy Systems, Volume 113, December 2019, Pages 56-70.
- [5] A. Khan, M. Ahmad, M. A. Bhatti, M. A. Ijaz and S. Ullah, "A Comparative Study of Multilevel Inverter Topologies with Reduced Switches," 2019 International Conference on Engineering and Emerging Technologies (ICEET), 2019, pp. 1-5, doi: 10.1109/CEET1.2019.8711851.
- [6] Jainy Bhatnagar, Vikramaditya Dave, "A Comparative Study of Different Topologies of Multilevel Inverters", International Journal of Electrical and Electronics Engineers, Volume No. 9, Issue No 01, January - June 2017, Page 2050-2056.
- [7] Addagatla Nagaraju and Akkela Krishnaveni "Modified Multilevel Inverter Topology with Minimum Number of Switches", International Journal of Science Technology & Engineering, volume 3 issue 09 March 2017
- [8] Niralkumar Rakholiya et al. "Multilevel Inverter Topology" - International Journal for Innovative Research in Science & Technology volume 3 issue 11 April 2017.
- [9] Anjali Krishna R. and Dr. L Padma Suresh "A Brief Review On Multilevel Inverter Topologies" Conference on Circuit, Power and Computing Technologies [ICCPCT] 2016.
- [10] Y. Sato, M. Kawasaki, and T. Ito "A Diode-Clamped Multilevel Inverter with Voltage Boost Function", 8th International Conference on Power Electronics - ECCE Asia May 30-June 3, 2011.
- [11] Kamaldeep Boora and Jagdish Kumar "General topology for asymmetrical multilevel inverter with reduced number of switches", IET Power Electronics 2017
- [12] Aditay Vardhan Singh, Ravi Shankar Singh, "A Comparative Study of Multilevel Inverter Topologies", IRJET, Volume: 05 Issue: 03 | Mar-2018, pp 1009-1014.
- [13] Shraddha S. Lohakare, Dr. Pravin M. Sonawane, "Comparative Study on Five and Nine Level MLI for Percentage THD Reduction", IJRECE VOL. 7 Issue 1 (January- March 2019) ISSN: 2393-9028 | ISSN: 2348-2281 (Online)

- [14] M. Ahmad, T. Muhammad, R. Uzaman and O. Khan, " A Novel Asymmetric Three Phase Multilevel Inverter with Reduced Switches", Sukkur IBA Journal of Emerging Technologies , 2018.
- [15] Pallavi Appaso Arbune, Dr. Asha Gaikwad, "Comparative Study of Three level and Five level Inverter", International Journal of Advanced Research in Electrical, Electronics and Instrumentation Engineering, Vol. 5, Issue 2, February 2016, pp 681 – 686.

BIOGRAPHIES



Titas Bhaumik, with academic experience of over 6 years, is currently working as Assistant Professor, Dept of EE, AIEM (JIS Group), resides in Mogra, West Bengal, India.



Sumangal Bhaumik completed his M.Tech. in Electrical Engineering from University of Calcutta. Now he is attached with Techno and JIS group as a faculty of Electrical Engineering Department, currently resides at Kalyani, India.



Surajit Paul, currently at third year of B. Tech in Electrical Engineering, AIEM, resides in Kolkata, India.



Snehashis Mitra, currently at third year of B. Tech in Electrical Engineering, MCKV Institute of Engineering, resides at Howrah, India.