

Thermal Artwork Transferring Machine for PCB Manufacturing

Akshay Ingole¹, Sangram Kamble², Prof. Pawan G. Alhat³

^{1,2}Student at NIELET, Aurangabad

³Assistant Professor at NIELET, Aurangabad

Abstract - Values for circuit board (PCB) laminate dielectric constant (D_k) and dissipation factor (D_f) employed in circuit design and signal integrity (SI) modeling are typically those presented on laminate maker datasheets. In most cases, these values are derived from measurements on samples which haven't been exposed to thermal stresses representative of the pc circuit card (PCB) assembly process. This paper discusses the changes in D_k and D_f values for a spread of laminate materials following simulated assembly thermal exposure of test vehicles to six SMT cycles at 260°C (Pb-free) or 225°C (SnPb eutectic). an additional concern arises around a control of operating temperatures upon the effective D_k and D_f of PCB materials. due to thermal radiation from active IC devices, power supplies, etc., the operating temperature of PCBs within a network equipment chassis is typically above the 23-25°C value at which D_k and D_f are measured and reported. This paper also describes the changes in D_k and D_f observed when the test samples were measured at temperatures of 70°C and 85°C.

Key Words: Atmega 328, temperature sensor, relay, pcb board.

1. INTRODUCTION

The thermal design of PCBs is defined because the process by which the warmth resistance from the warmth source to the warmth exchanger is reduced by cooling measures with thermal transfer characteristics or the viscosity of the thermal fluid is controlled to within a good distance. Hot release pad, hot pad or simply thermal, may be a computer circuit (PCB) pad connected to bobby pour employing a hot connection. it's sort of a normal pad with bobby "spokes" that connects to the encompassing brass.

The dielectric constant(D_k) and dispersion factor(D_f) of published circuit board(PCB) laminate accoutrements are laid low with the proportions of certain raw accoutrements (resin, fiberglass, and voluntarily, padding) present within the finished product. During the merchandise process at the fabric maker's plant, these factors are exposed several times to elevated temperatures during the manufacturing process which yields finished pre-preg. Those pre-pregs, which are latterly laminated into bobby-sheathe core accoutrements, are exposed to a different thermal cycle within the laminating press, during which the resin element becomes cured In a PCB fabrication shop, the inner- subcase circuit patterns are first imaged and etched onto core

accoutrements, and therefore the etched cores and prepress are piled within the applicable subcase order. Also the fabrication shops use their own laminating press to cure the prepreg layers and yield a laminated multilayer panel. The lamination press temperatures, at both the fabric manufacturer and therefore the board shop, are generally within the range of 180- 185 °C for FR4- class accoutrements , and kindly advanced(185- 215 °C) for- FR4 resin systems with low D_k and D_f . sedulity-standard test styles for D_k and D_f may be performed on either of two general classes of test vehicle a) an individual bull- sheathe or bottomless distance of core material, or b) a finished bare published circuit board. The laminate maker measures test vehicles of either or both types, and the corresponding D_k and D_f values are reported on the maker's product data wastes. In either case, the maximum temperature to which the test vehicle is exposed during manufacturing up to the time of test does not exceed the upper ranges(185 °C to 215 °C) noted over.

At the board shop, after the evidence of the external circuit pattern, the panel undergoes a fresh thermal excursion when coated with a solder mask and cured in a rotisserie. Still, the maximum temperature in this process generally reaches 135- 150 °C and thus does not approach the ranges formerly endured during the lamination cycles. The board will be exposed to an advanced temperature(250- 260 °C) if Hot Air Solder Level(HASL) face finish is applied, but the duration of this excursion is fairly short(numerous seconds).

2. PROBLME STATEMENT

- Using protolithic films/wet film/ dry film far PCB manufacturing is costly.
- Traditional thermal printing uses printing technology which requires lots of gears a rolls and hence costly.
- Home method i.e. by using iron box is cost effective, though water is required to peel off the paper. Thus sometimes artwork doesn't print as exposed on copper clad laminate.

3. OBJECTIVES

The objectives of making this machine are to:

- Make a cost effective PCB artwork transfer machine.
- Easy to handle and user friendly heat pattern transfer machine.

4. BLOCK DIAGRAM

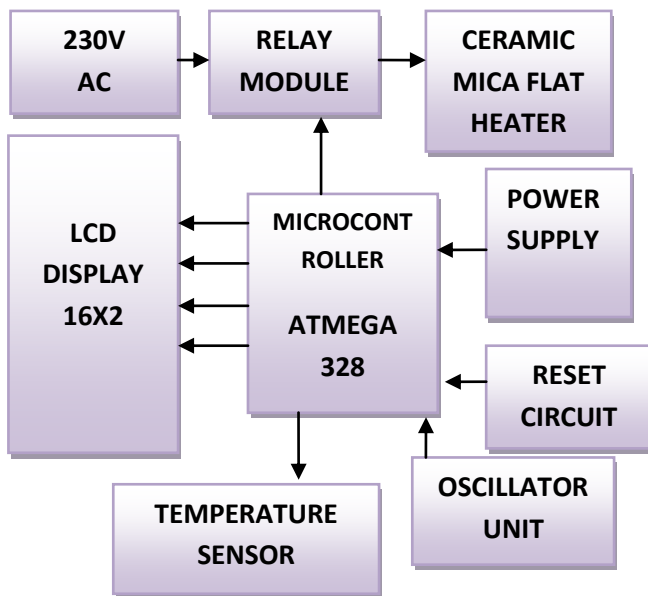

Fig.1: Block Diagram of System

5. METHODOLOGY

By using heat energy the artwork which is printed on paper will be transferred on copper clad laminate (FR-4). In this as thermal / heat energy is involved a protection mechanism is also used so that user or end user of this machine will be safe.

It is proposed to design and implement thermal exposing PCB machine. In this machine, a microcontroller is used for controlling and monitoring the machine. The microcontroller required three basic need power supply, reset circuit, oscillator unit. The power supply required 5v dc to run microcontroller. Oscillator circuit is providing clock signal to the microcontroller. The reset circuit is used for reset controller. The LCD display is used for display the temperature value. There are three switches to set the time, decrement the time, and increment time. The relay is electrical switch to control the heater.

Push Button: A push button is an electronic switch which Will be designed to initialize system and to set timer, increment and decrement time.

Atmega 328P: A microcontroller is used for coding and to run all the system.

Power supply: The device required 5v dc supply and ceramic mica heater is required 230v AC supply.

Reset Circuit: A power on reset circuit ensures the system power force stabilizes at the correct places, the timers of the processors settle directly, and that the load of the internal

registers is complete before the device actually starts working or gets powered up.

LCD Display: The display the used for showing the reading of temperature detector.

Temperature Sensor: LM35 is a temperature measuring device having an analog affair voltage commensurable to the temperature. It provides work voltage in Centigrade (Celsius). It doesn't need any external addition circuitry.

6. SOFTWARE

The Arduino Integrated Development Environment - or Arduino Software (IDE) - contains a text editor for writing code, a message area, a text console, a toolbar with buttons for common functions and a series of menus. It connects to the Arduino hardware to upload programs and communicate with them The IDE application is suitable for different operating systems. It supports the programming languages C and C++.

7. RESULT



Fig.2: Project Model

8. CONCLUSIONS

The deliverable is a product which can thermally transfer artwork pattern on to copper clad laminate. Similarly if it's required to have print on t shirt, it can be done using this device.

REFERENCES

- [1] S. He, E. Zhang, and Jeng-I Chen, "New Halogen free & Low Loss Material for High Frequency PCB Application", 3rd Int. Conf. Microsystems, Packaging, Assembly & Circuits Technology (IMPACT), 22-24 Oct. 2008, pp. 329 - 331.
- [2] K. Fukunaga and S. Kurahashi, "Dielectric Properties of Printed Circuit Board Insulations at Microwaves and Millimetre Waves", Int. Conf. Electromagnetics in Advanced Applications (ICEAA), 17-21 Sept. 2007, pp. 332 - 335
- [3] A Takahashi, N. Ooki, A. Nagai, H. Akahoshi, A. Mukoh, and M. Wajima, "High density Multilayer Printed Circuit Board for HITAC M-880", IEEE Trans. Components, Hybrids, and Manufacturing Technology, vol. 15, no. 4, Aug. 1992, pp. 418-425.
- [4] E. Bogatin, "Materials Requirements for High Performance Digital Systems", Circuitree Magazine, Aug. 2003, reprinted by Gigatest Labs (www.gigatest.com/Publications)
- [5] S. Hinaga, M. Koledintseva, P. Anmula, and J. Drewniak, "Effect of Conductor Surface Roughness upon Measured Loss and Extracted Values of PCB Laminate Material Dissipation Factor", Proceedings of the Technical Conference, IPC Expo/APEX 2009, Mar.31-Apr.2, 2009, Las Vegas, USA, paper S20-2.
- [6] A. Koul, P.K.R. Anmula, M.Y. Koledintseva, J.L. Drewniak, and S. Hinaga "Improved Technique for Extracting Parameters of Low-loss Dielectrics on Printed Circuit Boards", Proc. IEEE Symp. Electromag. Compat, Aug. 17-21, Austin, TX, 2009, pp. 191-196.
- [7] M.Y. Koledintseva, A. Koul, P. K.R. Anmula, J.L. Drewniak, S. Hinaga, E. Montgomery, and K.N. Rozanov, "Separating Dielectric and Conductor Loss for Rough Striplines in Printed Circuit Boards", Progress In Electromagnetic Research Symposium (PIERS), Moscow, Russia, Aug. 18-21, 2009, p. 213-214.
- [8] IPC-4562A – Metal Foil for Printed Board Applications, IPC Association, April 2008
- [9] Agilent Network Analysis Applying the 8510 TRL Calibration for Non-Coaxial Measurement, Product Note 8510-8A, Agilent Technologies.
- [10] IPC-TM-650 Test Methods Manual 2.5.5.5C and 2.5.5.5.1, IPC Association (<http://www.ipc.org/ContentPage.aspx?pageid=ELECTRICAL-TEST-METHODS>)
- [11] E. Bogatin, S. Begley, and M. Resso, "The Role of Dielectric Constant and Dissipation Factor Measurements in Multi-gigabit Systems", DesignCon, 2007.
- [12] N. Buinno and I. Novak, "Frequency Domain Analysis and Electrical Properties Test Method for PCB Dielectric Core Materials", DesignCon East, 2003.
- [13] Split Post Dielectric Resonators for Dielectric Measurements of Substrates, Applications Note 5989-5384EN, Agilent Technologies, 2006.
- [14] E. Kelley, "Reengineered FR-4 Base Materials for Improved Multilayer PCB Performance, <http://www.isola-group.com/images/media/ReengineeredFR4Materials.pdf>.

ACKNOWLEDGEMENT



- 1) Akshay M Ingole Roll No- 2019/B/75 B.Tech (ESE) National Institute of Electronic and I.T , Aurangabad (Maharashtra), India



- 2) Sangram S Kamble Roll no - 2019/B/82 B.Tech (ESE) National Institute of Electronic and I.T , Aurangabad (Maharashtra), India



- 3) Pawan G Alhat Project Engineer National institute of electronic and I.T , Aurangabad (Maharashtra), India