

RAPID FIRE EVACUATION SLIDE

Jubi Biju¹, Sreekutty Sivadas², Joby Joy³, Ashera Asharaf⁴, Fr. Dr. Bennet Kuriakose⁵

^{1,2,3,4}Students, Department of Civil Engineering, St. Joseph's College of Engineering and Technology Palai, Kerala, India

⁵Associate Professor, Department of Civil Engineering, St. Joseph's College of Engineering and Technology Palai, Kerala, India

Abstract- Emergency mass evacuation of buildings has been a worldwide difficult problem. Although the height and the number of buildings is increasing every year the fire evacuation methods in buildings of high people concentration like shopping malls, schools, hospitals remain unchanged. Currently high rise building evacuation mainly depends on ordinary staircases. There is also joint evacuation method of elevator and staircase. In India there is no alternative to traditional staircase evacuation for mass evacuation.

Hence a new evacuation device for fire escape is proposed in this project. The device mainly consist of special spiral slide with shunt valve mechanism. For analysing the applicability of the proposed system, a scale down model is made and experimental studies on evacuation efficiency are investigated. A motion simulation study of the slide is performed to assess the safety of the evacuees throughout the slide.

Design of the slide for safe movement of evacuees is determined. One to two number of rounds in each floor with a slope of at least 25 degrees is necessary for the smooth flow of persons. Path obtained through both experimental and simulation show that people will not be thrown out of the spiral slideway during evacuation. Through experimental study it is estimated that people from a height of 12 m can be evacuated within 7 minutes.

The suggested slide would provide as an alternate evacuation technique in high rise buildings which would require evacuees to use minimal physical effort and no electricity for its use. This novel technique is expected to be advantageous compared to traditional evacuation methods.

Key Words: High rise building, Emergency evacuation, Special spiral slide, Shunt valve

1. INTRODUCTION

Due to the commercial and educations development in large cities, urban population and population density are increasing and being the only available solution, high-rise building is becoming popular day by day. Modern day construction technology aided by 3-D modelling using sophisticated software is also supporting this concept to

enable maximum occupancy per unit ground area. As high-rise buildings are increasing rapidly all over the world, it is also carrying few concerns along with them. One of the prominent concerns is fire safety, and presently, saving human life and property due to fire is a major threat to such buildings. This is one of the major challenges which need to be resolved on priority.

1.1 Need for the study

With the development of modern cities, higher rise buildings are being built and they are increasing in height. Evacuation for people in high rise buildings has long been a vital but difficult problem due to multiple floors, height, and concentrated people. Rapid urbanization and population growth have led to the construction of many high rise building's global concerns over the evacuation of the occupant's safety in extreme events such as fire. The issue has even restricted the height of tall buildings around the world. Functional diversification of such buildings is making firefighting and evacuation operations more difficult. There are various vertical components like stairways, elevator, shaft, pipes, ducts, electrical shafts through which fire may spread very fast, if proper precautions are not taken. Moreover, the current cladding system increases the difficulties for the fire fighters to do firefighting and rescue. This may result in reduction in available evacuation time. It gets further complicated as normal elevator could not be used during the fire and stairs are the only channel for vertical evacuation.

1.2 Slide details

The new evacuation device mainly consists of special spiral slides and shunt valve. The projection on plane for special spiral slide is '8' shape which consists of slide ways. The working principle of new evacuation device is very simple just like the sliding ladder in children's park. In this system people sit or lie on the slide by means of the gravity of the earth they can slide down to the ground floor without any energy and physical power and also no any manipulation technique is required. In order to avoid injury due to friction during sliding, protective pad is provided for each person

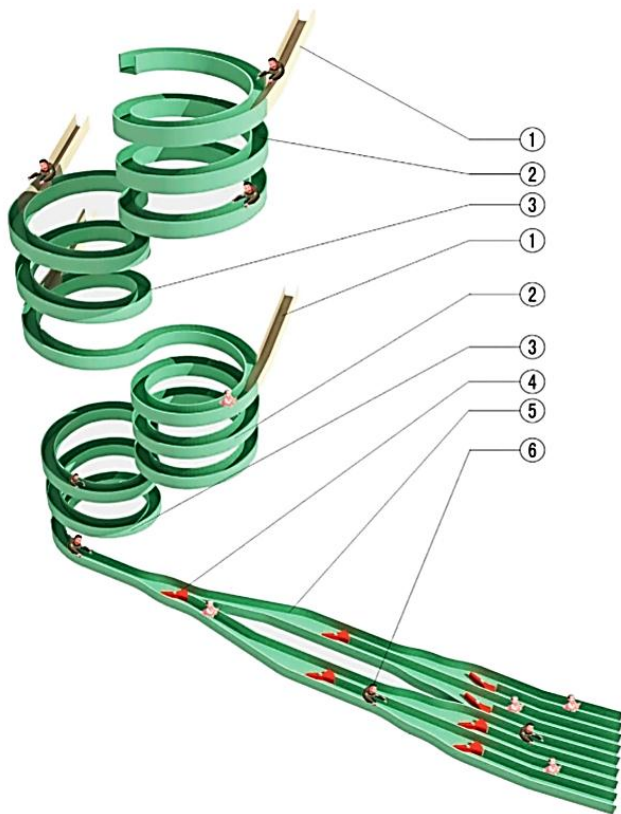

Figure 1: Proposed fire evacuation slide

The notations in figure 1 indicate the following: 1. Slide way at entry; 2. Main slide way of at clockwise rotation; 3. Main slide way of at counter clockwise rotation; 4. Shunt valve; 5. Slide way of first floor ; 6. Person of slide way down. The following figure shows the working of the shunt valve provided. Shunt valve reduces congestion.

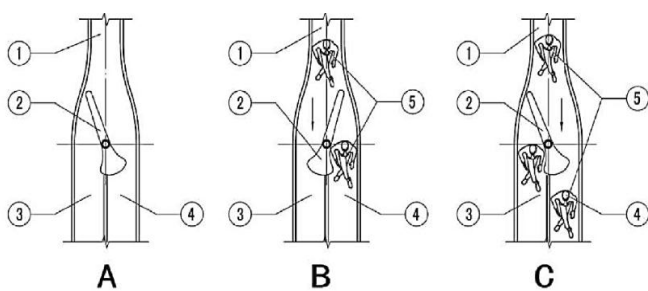

Fig 2 : Shunt valve mechanism

In fig 2, (A) case 1 (no slider); (B) case 2 (slider sliding into left branch) ; (C) case 3 (slider sliding into right branch) (1) Upper slide; (2) Shunt valve; (3) Right branch; (4) Left branch; (5) Slider

When people quickly slide down to the ground floor, an important issue is to prevent people from getting jammed and stampede at the ground floor. Buffer and routing technology are considered for the main slide way at

between the second floor and the ground floor. Through three routings, a mono-slide way can be diverted into eight branch slide ways. Hence the evacuation capacity can be increased.

1.3 Methodology Adopted

This project is exploring the possibility of developing the proposed evacuation slide for fire evacuation. For this purpose experimental study on scale down model of the slide is conducted to obtain evacuation time and path. Motion simulation study in solid works software is also done to find the time and path. On comparing both results we can access whether this slide is safe for application.

2. LITERATURE SURVEY

2.1 Current Methods of Fire Evacuation

The 9/11 event in 2001 in the United States lasted at least one hour from the plane hitting the two towers to complete collapse. If a quick escaping device (unpowered) is available in the building, all people could have been completely evacuated within half an hour and thus fewer people would lose their lives. According to Times of India every fifth fire related death take place in India. Hence architects and experts from all around the world are studying a quick escaping device for high-rise buildings. The studies mainly include the following:

1. Evacuation research

Using a computer model to simulate the evacuation of people in high-rise buildings. The study is somehow accurate but difficult to be used in practical engineering application due to computer virtual space.

2. Co-evacuation by elevators and staircase

The method is better than staircase alone but the evacuation speed is still slow. Moreover, it is difficult for elevator to quickly evacuate large numbers of people in a short time. Once power supply is damaged by fire or unexpected accident, it will lose function.

3. Co-evacuation by staircases and slide way

A stainless steel slide is designed by the side of the existing elevator shaft with same slope as the staircase. A semi-circular stainless steel slide is designed at staircase platform. The stainless steel slide can be put into non-operation status as shown in Fig.3. When the building is on fire, open it manually and then form into a slide way in a relatively short period of time. When the slide way is not in use, put it into non-operation status through manually-operated counterweight so that the normal space of the staircases can be resumed. The advantage of this

technology is no need of power. Disadvantages are three: 1).It needs manual operation to form slide way in case of fire emergency. This requires for technical person who is familiar with the operation and it is difficult for an ordinary person who is going to escape from fire 2) Stampede may occur under emergency cases causing security risks 3) The evacuation speed and capacity are limited. Current information on the internet showed that the maximum floor can be used for such method is 32 in residential buildings only. 4) Corners of the slide may cause pile ups and block the path.



Figure 3: Combined stair and slide way evacuation

4. Vertical evacuation lift

Its principle is to make use of the gravity of the human body. The advantage of this method is no need of electric power while the disadvantage is that it is not suitable for evacuation of large crowds of people.

5. Landing escaping bag

Landing escaping bag as shown in Fig.4. Its advantage is no need of electric power while the disadvantage is that only a few people can be evacuated and thus not suitable for high-rise buildings.

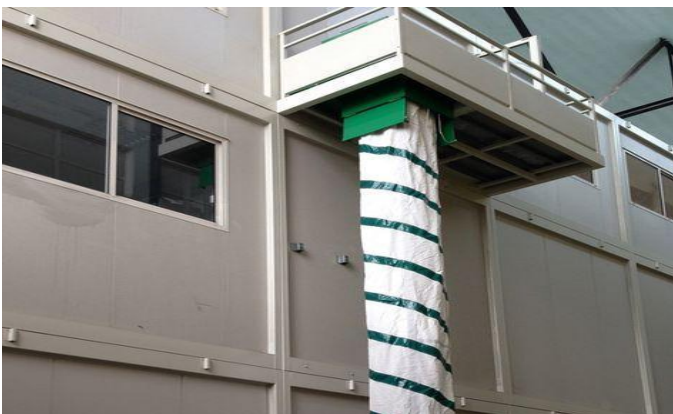

Figure 4: Chute evacuation

6. Tilt slide way escaper

Tilt slide way escaper, as shown in Fig.5. Its advantage is no need of electric power while the disadvantage is that it has to be installed at site before using and cannot be used for high-rise building.



Figure 5: Tilted slide evacuation

Notable contributions have been made by the following authors for developing evacuation techniques:

Enrico Ronchi (2021) provided an over view of most commonly used modelling methods to represent the evacuation process. Presented through a structure matching the engineering time line method of evacuation. Development process discussed considering data driven empirical correlation and theory based modelling approach. Particular attention is given to the representation of the impact of smoke on the evacuation process, as this is an important issue for fire safety engineering. Finally, a discussion on existing methods and procedures for the verification and validation of evacuation models is presented and the need for their standardization is advocated. This paper helps to identify a list of challenges with the currently available assumptions adopted by evacuation models and pursue research efforts aimed at addressing them.

Xin Zhang (2017) suggested a new evacuation device for high-rise buildings in fire accident was proposed and studied. This device mainly consisted of special spiral slide way and shunt valve. People in this device could fast slide down to the first floor under gravity without any electric power. The calculation results shows that the evacuation speed of new device is much faster than traditional

staircases. The plane simulation test has shown that human being in alternative clockwise and counterclockwise movement will not become dizzy. The new evacuation system is of simple structure, easy to use, and suitable for evacuation and partly used as vertical downwards traffic, which shows light on solving worldwide difficulties on fast evacuation in high-rise buildings. We took the proposed idea and doing further study to evaluate the practicality of the slide.

Fang Ziming (2004) conducted evacuation experiment is carried out in Shanghai Tower with a vertical height of 583 m, which is the second tallest building in the world provided a new measurement method for crowd density and then fundamental diagram of velocity -density relations in super high rise building is presented. These results provides basic data for the design of emergency evacuation facilities and formulation of emergency plan for super high rise buildings.

V.A.Oven (2009) studied two issues: firstly, what methodology should be pursued to accurately model an evacuation problem and the derivation and extent of parameters needed to fully utilise the potentials of the advanced computer models, the second issue is an investigation of the evacuation behavior in a high-rise office building in Istanbul. It is found that exit knowledge and the preferences of occupants can severely slow down the evacuation process. Fires closer to the ground floor increase the death toll significantly. Failure in the activation of the sprinkler system or the absence of the system altogether can have disastrous effects on the loss of life.

3. METHODOLOGY

3.1 Additive Manufacturing

The process of creating three dimensional solid objects from a digital file is called 3D printing. The creation of a 3D printed object is done using additive processes and hence called additive manufacturing. In an additive process an object is made by laying down successive layers of material until the object is created. Each of these layers are a thin sliced cross-section of the object.

The process begins with building a 3D model in a software. The next step is to prepare it for your 3D printer. This is called slicing. A 3D model is sliced into hundreds or thousands of layers and is done with slicing software. Once the file is sliced, it's ready for 3D printing. Feeding the sliced file to the printer can be done using USB, SD or Wi-Fi. This sliced file is now printed layer by layer.

A Fixed Deposition Manufacturing (FDM) 3D printer works by depositing melted filament material over the base of a build platform layer by layer until you have a

completed part. To use a FDM machine, a spool of this thermoplastic filament like ABS or PLA is loaded into the printer. Once the nozzle reaches the desired temperature, the printer inputs the filament through an extrusion head and the nozzle.

This extrusion head is connected to a three-axis system that allows it to move across the X, Y and Z axes. The printer extrudes melted material in thin strands and deposits them layer by layer along a path determined by the design inputted. Once deposited, the material cools and solidifies. Likewise, all layers are printed.

3.2 Scaled Model Fabrication

The slide is designed for all its dimensions based on EN 1069-1:2017 which is the European standard code for water slides. From this code, the dimensions of width of slide way, sidewall height are taken. Width of slideway is 0.8 m and sidewall height of 0.9m is provided. Further the slide is scaled down to the ratio 1:80. This makes it easily fitted into the build envelope of the machine and creates a model of appropriate size without large expense on material. Solidworks software was used to create the solid models. The spiral slide, landing part and shunt valve were drawn as different part files and separately printed as shown in Fig.6. Later these parts are assembled to form entire slide as in Fig.7

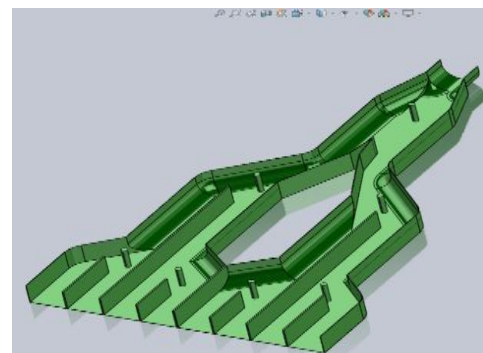

Figure 1: Landing part and shunt valve in Solidworks

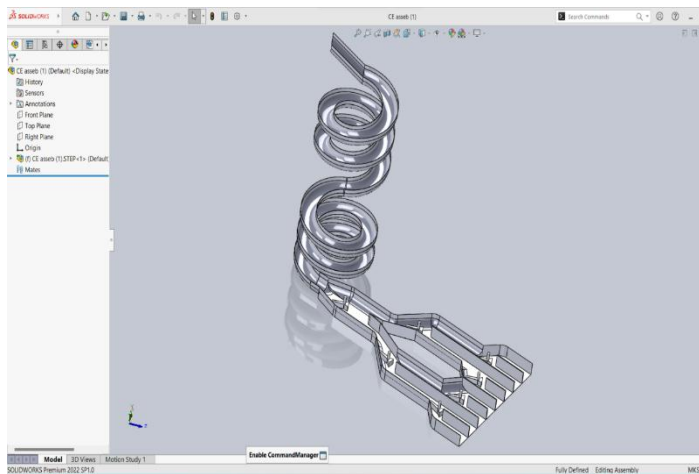

Figure 2: Solidworks assembly file of the slide

For the model to be given as an input to the printer, it has first been converted to a .stl file shown in Fig. 8. Solidworks allows files to be exported as .stl format. This stereolithography model is sliced using the slicing software Snapdragon. The manufacturing process is initiated with a layer thickness of 0.16 mm, infill density of 15%. The material used was polylactic acid (PLA). It took 55 hours for the machine to fabricate this. The process is shown in Fig. 9. The printed model surface is made smooth and paint is applied. Hence the scaled down model is completed as shown in Fig.10.

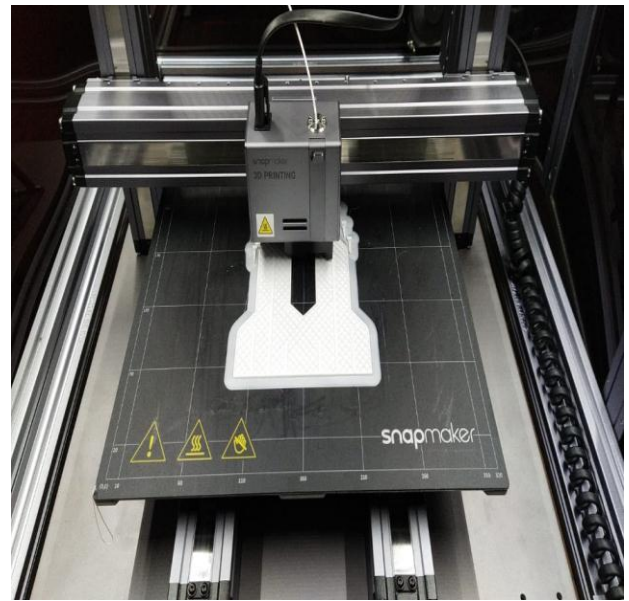

Figure 4: 3D Printing in progress



Figure 5: 3D Printed model after finishing

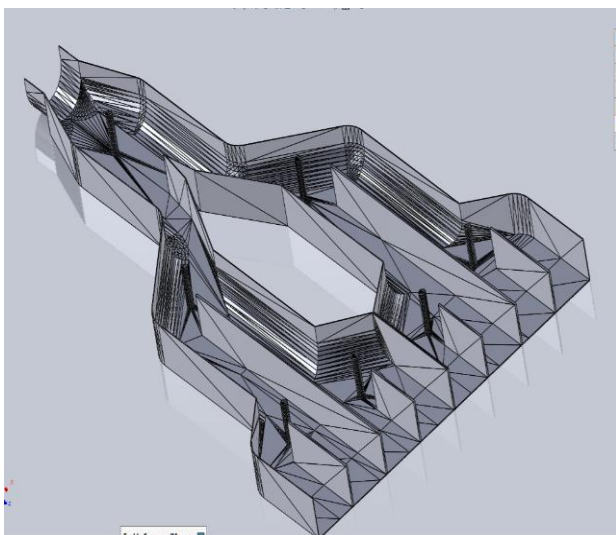

Figure 3: .stl file

For the purpose of analysing the parameters of a human on this scaled down model, human mass is also scaled down in the same ratio as the slide by considering the relation between mass, density and volume.

This is made under the assumption that volume of any shape is proportional to cube of its dimension as in case of cube $[V= l^3]$ and sphere $[V=4/3\pi r^3]$.

Average mass of a human globally is 62 kg (m_1). Let the scale down mass be m_2 . Density of a human body is 1000 kg/m^3 (d_1). By following the above assumption, the volume of scaled down object will be $v_2= v_1/80^3$

$$m_1 = d_1 \times v_1 \tag{1}$$

$$m_2 = d_2 \times v_2 \tag{2}$$

Dividing (2) by (1)

$$m_2 / m_1 = d_2 / d_1 \times v_2 / v_1$$

$$m_2 / m_1 = d_2 / d_1 \times (v_1 / 80^3) / v_1$$

$$m_2 = d_2 / d_1 \times m_1 / 80^3$$

$$m_2 = d_2 / 1000 \times 62 / 80^3$$

By selecting mild steel as the material with density $d_2 = 7850 \text{ kg/m}^3$, we get the scaled down human mass as 0.95 g. Mild steel spheres are commonly available as ball bearings

3.3 EXPERIMENTAL STUDY

A sphere of scaled down mass is employed as the sliding object for the study. The path taken by the object confirms that the width and side protection height provided would ensure safety of the evacuees by preventing them being thrown out. The sliding time is noted as 5.12 seconds.

Different weights were tested and their times are noted

Material	Weight(g)	Sliding Time(s)
Mild steel	1.04	4.66
Mild steel	0.43	5.65
Plastic	0.22	4.95



Figure 6: Images of object to check for collision

Images were captured when the object sliding time was measured. In order to avoid collision, the evacuee should ensure that the incoming person from the top floors are away by a minimum of 1 m distance.

Since the overall sliding distance is constant and the starting velocity is zero, the acceleration can be calculated using $a = 2s/t^2$. Once the acceleration is found out the friction coefficient can be calculated using

$$\mu = g \cos\theta - a / g \cos\theta$$

which is derived from Newton's law (Chang and Chen 2010). The slide is provided a slope of 12 degrees. On solving the above equation, a friction coefficient of 0.18 is obtained.

3.4 COMPUTER MODELLING AND SIMULATION

3.4.1 SOFTWARE VALIDATION

Motion analysis is done in Solidworks software. In order to rely on the results given by the simulation software it is necessary to validate its results with experimental results. The sliding time of a small slide from nearby playground shown in Fig.12 is taken experimentally by iterating 10 times which is then compared with time shown by simulation software.



Figure 7 : Validation Slide

Experimental sliding time is obtained as 1.54 s. Later the slide is modelled in Solidworks a hemisphere of equal weight as the slider is given. Kinematic friction coefficient = 0.3, static friction coefficient = 0.15 and motion analysis is done. Software simulated sliding time is obtained as 0.75 s.

3.4.2 SIMULATING THE SLIDE

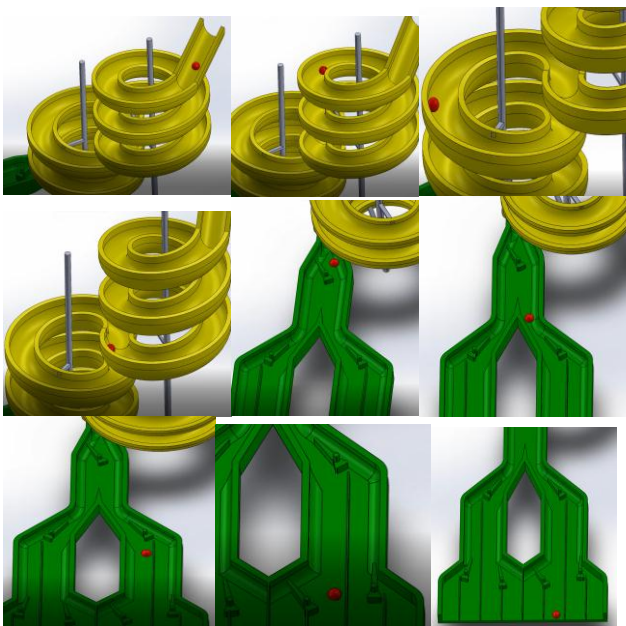

Figure 8: Solidworks simulation of spiral slide

The motion analysis of the evacuation slide is done next with the help of motion add in feature of Solidworks. Images of the simulation recorded is shown in Fig.11. The weight of the body sliding is given same as that of sphere in experimental study. The sliding time is obtained as 6.084 s.

4. RESULTS AND DISCUSSION

Experimental study is conducted by letting a sphere having a scale down mass of a human through the 3D printed slide. The sliding time is taken as the average of ten attempts and it is obtained as 5.12 s. The time obtained is only an approximate value. The surface of the model is rough and may contribute to additional friction. In real case scenario, additional cotton covers are provided to minimise friction.

An evident problem that may arise is the collision between a person sliding and a person incoming from a floor. To avoid injury the person incoming should ensure that the person from top floor is at least a meter away from the inlet to slideway. Another way is to install a shunt valve like mechanism at the junction of main slideway and inlet slide from each floor so that only one person occupies the slide at a time.

The model 3D printed was for three storeys with 2 rounds in each floor. This meant that the slope of slideway is about 15 degrees, which is not sufficient for people to slide smoothly under gravity. Hence a slope of at least 25 degrees is required.

Different weights were tested and their sliding times are given in table 1. This indicates that heavier person will evacuate quickly and that the friction between two surfaces affect the sliding speed.

Table 1: Sliding time of different weights

Material	Weight(g)	Sliding Time(s)
Mild steel	1.04	4.66
Mild steel	0.43	5.65
Plastic	0.22	4.95

The path taken by the slider is within the flume surface and people will not get thrown out during motion. During simulation some of the assumptions made are

- The object is sliding with point contact
- Air resistance is neglected
- The flexibility of human body is not considered

Due to these assumptions variations in results of simulation and experiments occur.

Motion analysis performed in the slide for validation yielded a sliding time of 0.75 s whereas experimentally 1.54 s is obtained as shown in Fig.14.

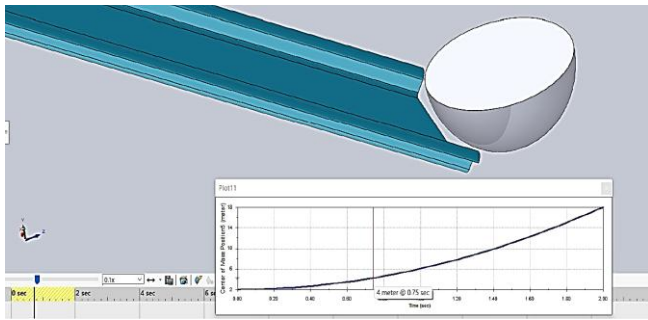

Figure 9: Sliding time of validation slide

The spiral slide is simulated and the sliding time is obtained as 6.084 s whereas experimentally 5.12 s is obtained as shown in Fig.15. This value on scaling up gives the evacuation time for a person to be evacuated from three storeys or 12 m height as 7 minutes.

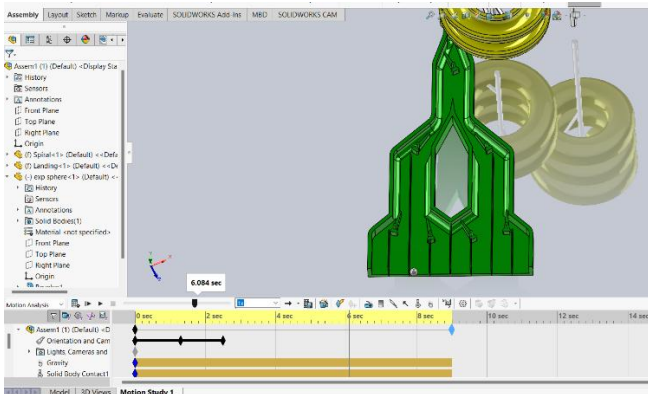

Figure 10: Sliding time of spiral slide

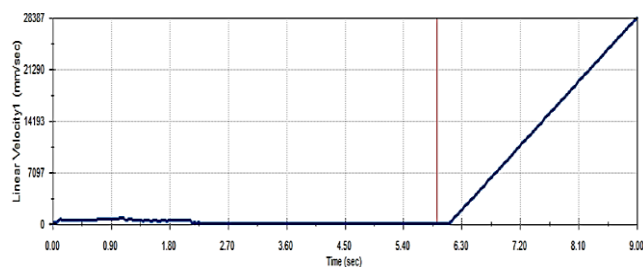

Figure 11: Velocity through landing part

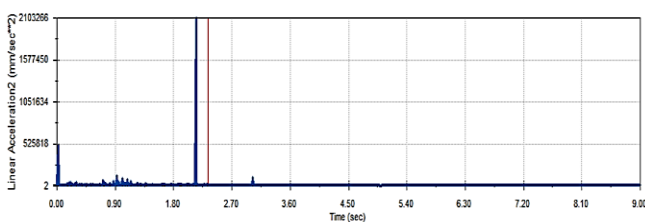

Figure 12: Acceleration through landing part

Linear velocity of the sliding body through the landing portion is obtained as a graph in Fig.16. The graph shows that as the slider descends down landing portion, with very little velocity and hence they can easily get up. Similarly, the acceleration plot is also obtained as shown in Fig. 17. A peak in acceleration is seen at the junction of spiral slideway and landing portion.

CONCLUSION

One of the most prominent concern for a high rise building is its fire safety provision. The possibility of developing a spiral evacuation slide has been explored in the project. This included design of the fire evacuation slide and its components, building a scaled down model of the slide to conduct experimental study and to analyze the safety of the evacuee during sliding through Solidworks motion analysis. Slide was designed and 3D printed and experiments show that the evacuees are well within the flume surface and there is no case of people being thrown out. One to two number of rounds in each floor with a slope of at least 25 degrees is necessary for the smooth flow of persons under gravity. Through experimental study it is estimated that people from a height of 12 m can be evacuated within 7 minutes. Stainless steel evacuation slides are a great alternative to more cost and maintenance intensive fire staircases. This evacuation system would be very advantageous if implemented. More studies need to be conducted to prevent injury when two people slide down right after each other, there is a change that one of them would be hit by shunt valve.

Fire related deaths can be minimised drastically due to high evacuation capacity and faster evacuation in high rise buildings and places of dense people gathering like malls, hospitals etc. Disabled people can evacuate effortlessly thereby saving lives of the marginalised. Elderly and children can evacuate with least physical effort.

REFERENCES

- [1] Xin Zhang, "Study on rapid evacuation in high-rise buildings," Engineering Science and Technology, an International Journal 20 (2017),1203–1210
- [2] Nils Johansson, "Evaluation of a zone model for fire safety engineering in large spaces," Fire Safety Journal 120(2021), 103122
- [3] V.A. Oven, N. Cakici, 'Modelling the evacuation of a high-rise office building in Istanbul,' Fire Saf. J. 44(2009) , 1–15.
- [4] Yao-jian Liao, Guang-xuan Liao, Siu-ming Lo, "Influencing factor analysis of ultra-tall building elevator evacuation," Proc. Eng. 71(2014),583–590

- [5] Ronchi E, "Developing and validating evacuation models for fire safety engineering." Fire Safety Journal(2020), 103020.
- [6] Chang K.H. and Chen C, " Design, Prototyping, and Experimental Validation for Recreation Waterslides," Mechanics Based Design of Structures and Machines 2010, 38: 516–529,