

Train automation using ARM7

Sadish Ramajayam Nadar¹, Ganapathyraman Lakshminarayanan², Ashutosh Mishra³,
Greeshma Nair⁴, Prof. Vaishali Mangrulkar⁵

^{1,2,3,4} Students, Dept. of Electronics and Telecommunication Engineering, SIES GST, Nerul, Maharashtra, India

⁵Assistant Professor, Dept. of Electronics and Telecommunication Engineering, SIES GST, Nerul, Maharashtra, India

Abstract - The primary goal of this research is to highlight the factors that are used in metro trains in several developed countries. Many metro lines have broken down in recent days due to a variety of factors, including human error. This can result in a variety of issues, including the loss of human life, train delays, and other mechanical issues that render the interior of a metro train unworkable, among others. These issues can be quite harmful because they can disrupt passengers' daily routines, and we all know how valuable time is in our lives. As a result, we require a precise and accurate transportation system for our convenience. The automatic model train has been updated to overcome this issue, and it now uses an ARM7 controller to operate automatically. The 32-bit LPC-2148 microcontroller is utilized as a CPU in this example to accomplish a variety of tasks. One of these is for the train to come to a complete stop when the IR sensor detects the platform and displays the platform area on a three-segment display. When the train detects an impediment, an obstacle detection unit is activated, and the necessary information is shown on the LCD display.

Key Words: ARM7, LPC2148, IR sensor, LCD display

1. INTRODUCTION

In this paper the problem with the railway analysis is to find cracks in the structure. Trains build great infrastructure and are an important means of transportation in many lands. Improper train repairs can lead to accidents. New railway technologies and better safety measures are being introduced from time to time, but accidents do occur. Thus, proper strategy is needed to maintain and evaluate tracks. In this paper, the proposed broken rail system automatically detects a faulty railway line without human intervention. Benefits include lower cost, lower power consumption and less analysis time, with this proposed system. The location of the faulty railway line can be easily identified and repaired immediately to save many lives. Urban railway transit has been getting more advanced, from trains to metro trains. Driverless metro trains are a smart multi-passenger solution that can work on its own. Driver-free technology meets a number of objectives, including maximum volume, speed and standardization, to reduce operating costs, adaptability, flexibility; it complements the idea of a new

way of travel. In this project, the problem about a train analysis is detection of cracks in the structure. Metro comprises a large infrastructure and is an important mode of transportation in many countries. The poor maintenance of the railways can lead to accidents. New technologies for railways and better safety measures are introduced from time to time but still accidents do occur. Thus, a proper strategy is required for maintenance and inspection of tracks. In this project, the proposed broken rail detection system automatically detects the faulty rail track without any human intervention. Minimal cost, low power usage, and quick analysis are just a few of the benefits. With this proposed technique, the exact location of the broken railway line might be swiftly found and repaired, perhaps saving many lives. The planned endeavor will look into a select high-risk regions and offer measures to lower the incidence of events in order to prevent mishaps like these. Human error or lacks of manpower are the most common causes of accidents. Anti-collision, automatic Track Fault Control, and tracking, among other key issues, will be discussed. The two will avoid colliding thanks to collision avoidance technology. If the track fails, accidents caused by faulty tracks will be averted. There are a few small features included, such as platform directions and a crowd-based lighting system. After an accident happens, the risk recognition feature will enable immediate emergency help without the need for human participation. Blocking sensors positioned close to the railway will be used to prevent collisions. Obstacle detection sensors using non-infrared LEDs and infrared receivers.

2. METHODOLOGY

The proposed prototype accomplishes the task by integrating the knowledge of embedded systems and instrumentation systems. It decreases the need of manual control as the whole system can be operated automatically. The prototype is capable of detecting obstacles in front of it and it also detects faults in the track through which it commutes. There are also sensors attached to count the number of passengers that enter and exit the train. A sensor to sense the internal temperature of the train bogey and to switch on the fan is also attached; a LDR is also used to turn on or off the light in accordance with the amount of light present in the bogey.

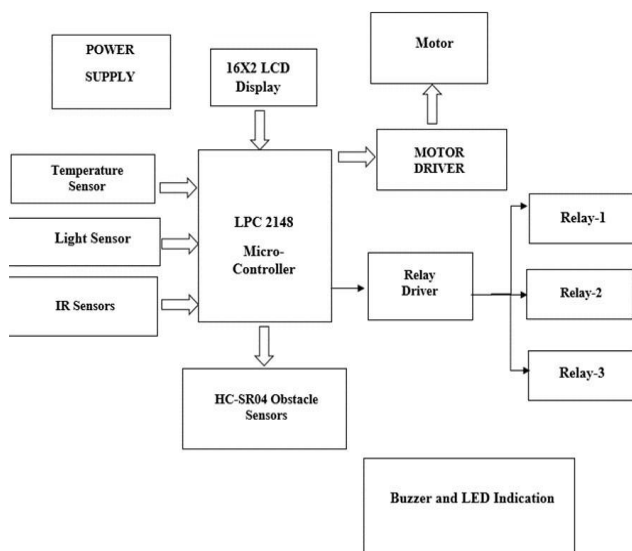

The train moves with the help of motor drivers, and we can identify whether the driver is functioning or not using the relay wherein we have used reverse motion the relay will only blink when the motor stops running thus saving some energy of the power supply. Person count will be functional whenever a person passes through IR sensors, If the first IR sensor is high and the second IR sensor is low, the person is going in; if the second IR sensor is high and the first IR sensor is low, the person is exiting. When both IR sensors are high and the trains stop moving, the IR sensors that are used to detect platforms operate, signaling that there is a platform. The LCD will display the side on which both IR sensors are high, indicating whether it is left or right. The HCSR-04 obstacle detection sensor will assist in determining whether or not there is a defect in the track through which the train travels; if a fault is discovered, it will be displayed on the LCD and the buzzer will buzz in order to alert the passengers as well as the control station thus ensuring the passengers safety. Each relay is used to depict the functions of respective sensors such as the temperature sensor, motor drivers and the LDR. The temperature level is also displayed on the LCD and with a rise in temperature the fans are switched on automatically to comfort the passengers that are commuting. The LDR observes the intensity of light if there is less light in the train bogey it automatically turns on the light and switches off the light if the condition is vice versa.

3. FLOWCHART

The following flowchart explains the about the complete mechanism of the train. As the train starts to move the motor drivers are set into action and the wheels start running as soon as the sensors detect the station the motors turn itself off and the passengers board the train. This whole scenario if captured using the sensors at the doors that count and display the number of passengers that come in & go out. The display also indicates on which side the platform is present and shows it on the display.

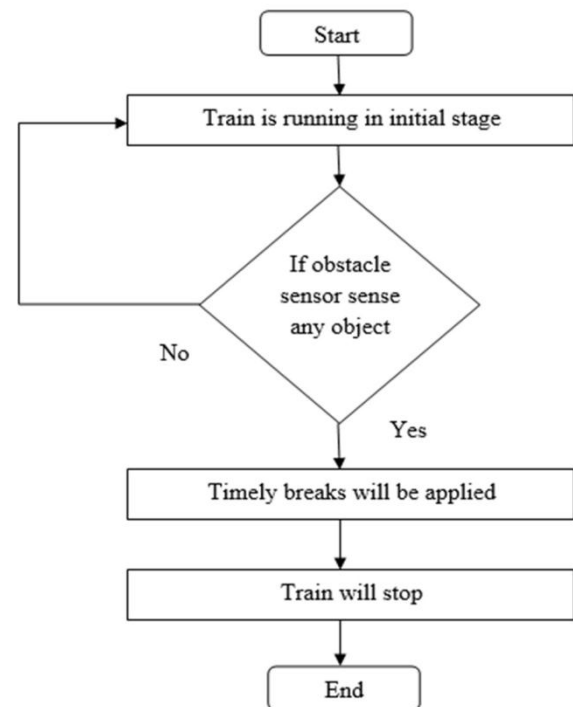
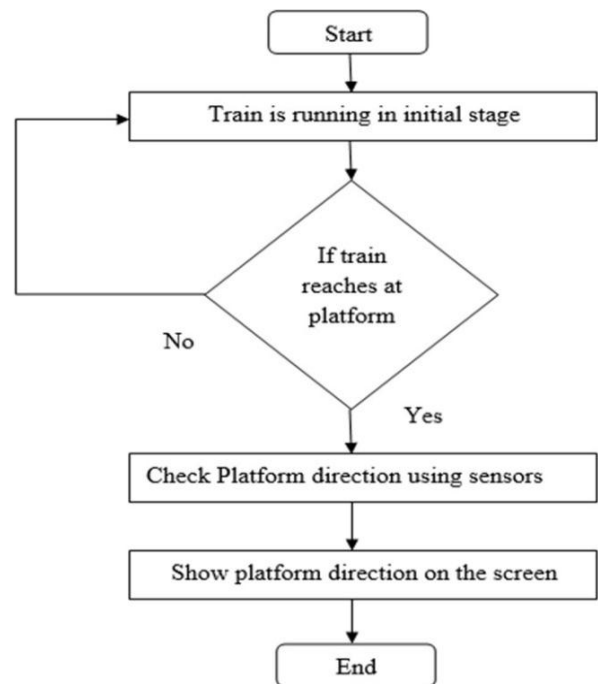

This flowchart indicates the functioning of obstacle sensors when a train is in motion and if the obstacle sensor detects any object in front of the train, the wheels of the train will be stopped. If any obstacle is not detected the train will be in continuous motion.

4. RESULT

- 1) If the temperature in the train rises above 36C the fan will be switched ON automatically and if the light

intensity of the train drops below 30% then the lights will turn on automatically.

2) Two IR sensors placed on the right and left of the train will help find the platform. The sensed platform will be displayed on the LCD towards the side where the platform is located, and the arrow will show direction on the 3-segment display.

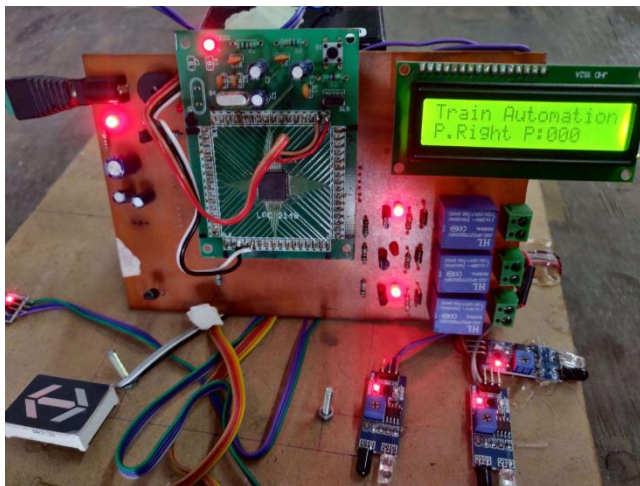

Fig 3.1 Platform Detection on right along with passenger count

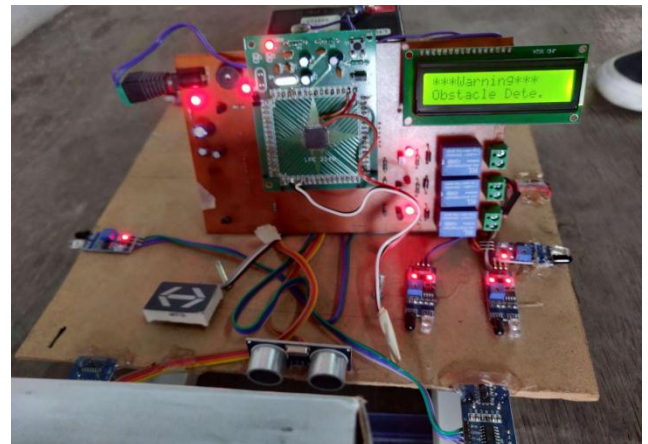

Fig 3.3 Obstacle Detection

4) The ultrasonic sensors are positioned right and left in front of the train, which will help detect an error while the train is in motion. If the left track is faulty then the buzzer will start to buzz, and a message will be displayed on LCD "TRACK FAULT ON LEFT" and similarly if the right side of track is faulty the LCD will display a message "TRACK FAULT ONRIGHT" and the train will stop moving.

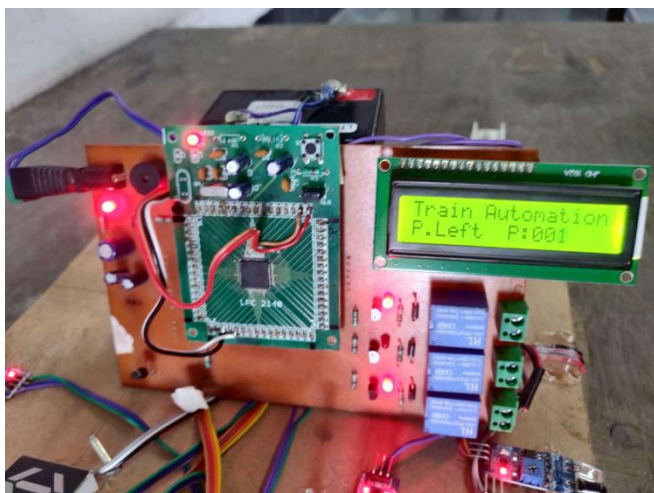

Fig 3.2 Platform Detection on Left

3) If there is an obstacle in front of the train the ultrasonic sensor will detect it and the buzzer will start buzzing and the message will be displayed "OBSTACLE DETECTED" and the train will stop moving.

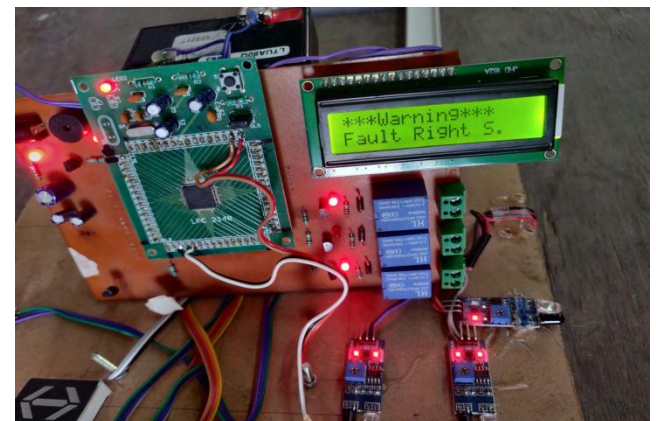

Fig 3.4 Fault on Right

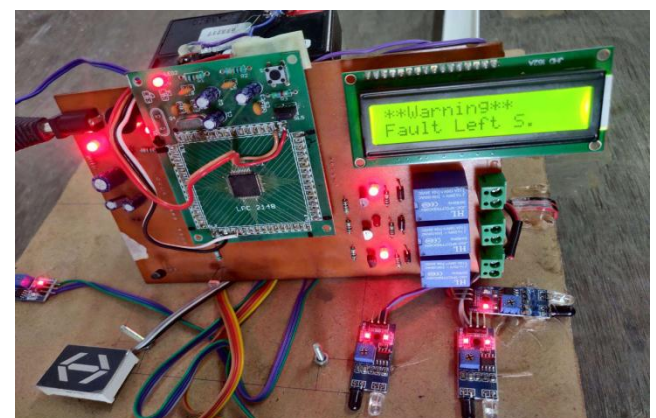

Fig 3.5 Fault on Left

5. CONCLUSION

The train prototype presented in this paper has a new approach for improving safety in railways. A common unspoken conclusion, the benefit of such engineering projects is that they expose students to a wide range of development opportunities. Such initiatives may just be a small part of what the future and technological integration may entail.

FUTURE SCOPE

High-speed sensors, which allow for faster and more efficient operation, can be added to this project to improve it. The use of the GPS-GSM model will also give us an upper hand in the near future. The existing system can be made capable of switching tracks whenever it detects a junction in the route it would be intelligent enough to decide and follow the specified route. As there will be more advancements in the technology domain the system will be safer and will be smart enough to provide clear and detailed decisions and recommendations.

REFERENCES

- [1] S V S Prasad, K Nishanth Rao, V Arun, D Laxma Reddy, "Auto Metro Train to Shuttle between Stations using Arduino" Volume-9 Issue-2, December, 2019.
- [2] Bharathi K V1, Divya, Raseeda. S, Tejaswini. N, Dr. Shankaralingappa, "Auto Metro Train Shuttle between Two Stations" Vol. 7, Issue 4, April 2018.
- [3] Prem Chand Bharti, Ratnesh Pandey, Ashwini. V .Mathurkar, Ashish mishra, Pradhyana. W. Bawangade, Umesh Bhandekar, "Automatic Metro Train to Shuttle between Two Stations" Volume 5, Issue 03, Mar 2018.
- [4] Prachi Bawangade, K. R. Dabhekar, P. Y. Pawade, "Monitoring System for Railway Track" IJSTE - International Journal of Science Technology & Engineering, Volume 3, Issue 10, April 2017.
- [5] Dapeng Zhang and Dian Wei Qian, "Study on leader- Follower Control in the Metro Unattended Train Operation," in proc. International Conference on Advanced Mechatronic Systems(ICAMEchS), Melbourne, Australia Nov. 30-Dec.3,2016.
- [6] Dr. B. Paulchamy, T. Sivamani, S. Viswanathan, R. Sugumaran, M. Ramadoss, S. Sakthivel "Automated Visual Inspection of Detecting Cracks and Obstacles on Railroad Track using Robot and Automatic Gate Control" International Journal of Innovative Research in Technology & Science, Volume 4, Number 2, March 2016
- [7] Fatima Imdad, Muhammad Tabish Niaz and Hyung SeokKim, "Railway TrackStructural Health Monitoring System" October 2015 15th International Conference on Control, Automation and Systems (ICCAS 2015).
- [8] K. Saritha, Ch. Lavanya, "Embedded Based Crack Inspection and Mapping System for Railway Track Maintenance by using Robot" International Journal of Scientific Engineering and Technology Research Volume.04, Issue no.32, August-2015.
- [9] Victoria J, Hodge, Simon O'Keefe, Michael Weeks, and Anthony Molds, "Wireless Sensor Networks for Condition Monitoring in the Railway Industry: A Survey" IEEE Transactions On Intelligent Transportation Systems, June2015.
- [10] Disha Bhat, Nayankumar Khatawkar, Neelavva Kadli, Dheeraj Veergoudar,"" International Journal of Engineering Research & Technology Vol. 4 Issue 05, May-2015. An Inspection System for Detection of Cracks on the Railway Track using a Mobile Robot.
- [11] Shailesh D. Kuthe¹, Sharadchandra A. Amale² and Vinod G. Barbuddhye, "Smart Robot for Railway Track Crack Detection System Using LED Photodiode Assembly" Advanced Research in Electrical and Electronic Engineering Volume 2, Number 5; April - June, 2015.
- [12] Thabit Sultan Mohammed, Wasam fahmi Al-Azzo, Mohammed Ahmed Akaak, Mohammed Laheeb Europe "Full Automation in Driverless Trains: A microcontroller- based prototype".Vol.3 Issue 7,July 2014.
- [13] V. Sridhar "Automated System Design for Metro Train", International Journal of Computer Science Engineering. Vol 1September 2012 pp. 30 -41.