

# Design and Fabrication of Tamarind Seed Removal Machine

Arihant Satpute<sup>1</sup>, Prasanna Patil<sup>2</sup>, Mayur Kulkarni<sup>3</sup>, Rishikesh More<sup>4</sup>

Guided by Prof. C. K. Gosavi, Dept. of Mechanical Engineering, PES Modern College of Engineering Shivajinagar Pune, Maharashtra, India

\*\*\*

**Abstract** - Tamarind is very helpful kitchen product. It's a very important ingredient in Ayurvedic medicines. These desires are consummated by tamarind pulp, which become obtainable once the separation of seed and cover from tamarind. The methodology of preparation of this pulp maybe a hand method that becomes a tedious and prolonged task to remove out the cover and seed from Tamarind. This operation require immense manpower needs. Tamarind seeds are separated manually which is less hygienical and grueling. All this method needs a ton of your time and hands which might be reduced by automation of the method. The machine consists of a seed separating the unit during which the fruits are subjected to shear force. Deshelled and dried tamarind is feed into tapered grooved disc one by one manually with facilitate of roller. The tapered grooved disc is driven by a motor at very low revolutions per minute. Once tamarind comes close to the cutter blade that is driven by a motor at high speed it shears the tamarind pulp. The projection in tray removes the tamarind seeds out of the oblong sieve, therefore the tamarind is deseeded. Since the machine is economical and efficient in separating tamarind seeds thus most of the farmers can afford it. The machine will scale back human labour, labour cost, and time.

**Key Words:** Terms—Tamarind, Design, FEA Static structural and Results, Fabrication and Manufacturing.

## 1. INTRODUCTION

The food industry is growing very fast because of the demand. The need of processing the food items has also to be quick and effective. Tamarind which is one of the major integrant in the food and used as everyday kitchen product. Tamarind fruits will be ripened in summer. They may be harvested after 6 months after maturity so that the moisture content level is reduced but usually, they are harvested as soon as they mature and processed.

### 1.1 Health Benefits

Tamarind fruit is anti-helminthic (expels worms), antimicrobial, antiseptic, antiviral, sunscreen and astringent and to promote wound healing, asthma, bacterial skin infections, boils, chest pain, cholesterol metabolism disorders, colds, colic, conjunctivitis, constipation (chronic or acute), diabetes, diarrhea, dry eyes, dysentery, eye inflammation, fever, gallbladder disorders, gastrointestinal disorders, gingivitis, hemorrhoids, indigestion, jaundice,

keratitis, leprosy, liver disorders, iron deficiency, nausea and vomiting (pregnancy related- generally eat raw unripe sour fruits), saliva production, skin disinfection/ sterilization, sore throat, sores, sprains, swelling (joints) and urinary stones.

## 2. PROBLEM DEFINITION

The need of processing the food items has also to be quick and effective. The methodology of preparation of this maybe a hand method that becomes a tedious and prolonged task to remove out the cover and seed from Tamarind. This operation require immense manpower needs. Tamarind seeds are separated manually which is less hygienical and grueling. All this method needs a ton of your time and hands which might be reduced by automation of the method.

## 3. OBJECTIVES

To develop method for deseeding tamarind. Design and fabrication of tamarind deseeding machine for household as well as small scale industries.

## 4. METHODOLOGY

Step 1: - We started the work of this project with literature survey with the help of research papers. We gathered many research papers which are relevant to this topic.

Step2: - After that we discussed about components which are required for our project.

Step 3: - After deciding the list of components, Concept 2D and 3D modelling are done by CATIA software.

Step 4: - The components were manufactured and then assembled together.

Step 5: - The testing is carried out and then the result and conclusions are drawn

## 5. DESIGN AND CALCULATIONS

### 5.1 Energy Required For Removing:

The cover of 150 gm Tamarind by 300gm weight  
= weight x height  
= 300 X 10<sup>-3</sup> x 9.81 X 300 X 10<sup>-3</sup>

= 0.8829 J

Hence, Energy required for removing the cover of 1000 gm Tamarind= 5.886 J

### 5.2 Shaft Selection:

- 1.To compute forces acting on shafts from gears pulleys or shredder blades.
- 2.Find bending moments from gears, pulleys and shredder blades.
- 3.To determine torque in shafts.
- 4.Determine suitability of shaft design and/or necessary size of shafting.

### 5.3 Standard Diameter of Shaft:

Diameter (in.)	Diameter increments (in.)
Upto 3	1/16
3 to 5	1/8
5 to 8	¼

Torsion of circular shaft

$$\frac{TL}{GJ}$$

Angle of twist,  $\theta = \frac{TL}{GJ}$

$\theta$  = the angle of twist (radians)

T = the applied torque (in-lb.)

L = shaft length (in.)

J = polar moment on inertia of the shaft cross section (in<sup>4</sup>)

G = shear modulus of elasticity of the shaft material (lb/in<sup>2</sup>)

I and J relationships for circular cross section areas

For solid circle,

$$I = \frac{\pi d^2}{64} \quad \text{and} \quad J = \frac{\pi d^4}{32}$$

For Hollow circle,

$$I = \frac{\pi(D_o^4 - D_i^4)}{64} \quad \text{and} \quad J = \frac{\pi(D_o^4 - D_i^4)}{32}$$

As we have achieved the bend stress and deformation values by considering the weight applied on the shaft on Ansys workbench and proceeded for further calculations.

### 5.4 Selection of Bearing :

For simplified calculations and to obtain an approximate value of the bearing life, the so-called "handbook method" is used to calculate the basic rating life. The basic rating life of a bearing according to ISO 281 is

$$L_{10} = (C/P)^p$$

Where,

$L_{10}$  = basic rating life (at 90% reliability), millions of revolutions

C = basic dynamic load rating, kN

P = equivalent dynamic bearing load, kN

p = exponent for the life equation

= 3 for ball bearings

= 10/3 for roller bearings, as used typically in axle box applications

The basic rating life for a specific bearing is based on the basic dynamic load rating according to ISO 281. The equivalent bearing load has to be calculated based on the bearing loads acting on the bearing via the wheelset journal and the axlebox housing. For railway applications, it is preferable to calculate the life expressed in operating mileage, in million km

$$L_{10s} = [(P_i \times D_w) / 1000] \times (C/P)^p$$

Where,

$L_{10s}$  = basic rating life (at 90% reliability), million km  
 $D_w$  = mean wheel diameter, m

### 5.5 Pressing Roller Calculations

Torque required by the motor to crush tamarind=?

Force exerted by a single seed = weight of seed x 9.81 m/s

$$= 10 \text{ g} \times 9.81 \text{ m/s}$$

$$= 0.001 \text{ kg} \times 9.81 \text{ m/s}$$

$$= 0.0098 \text{ N}$$

Considering weight at a time = 10 x 0.0098 N = 0.09 N

Hence total weight = weight of system + weight of seed

Total Load = 40 N + 0.09 N = 40.09 N

Hence torque exerted= 40.09 N x radius of roller = x 50 mm

= 2004.5Nmm (approx) = 2 Nm

Therefore we have selected a Wiper motor which has 50 rpm , 12 v rating.

## 6. CAD MODEL

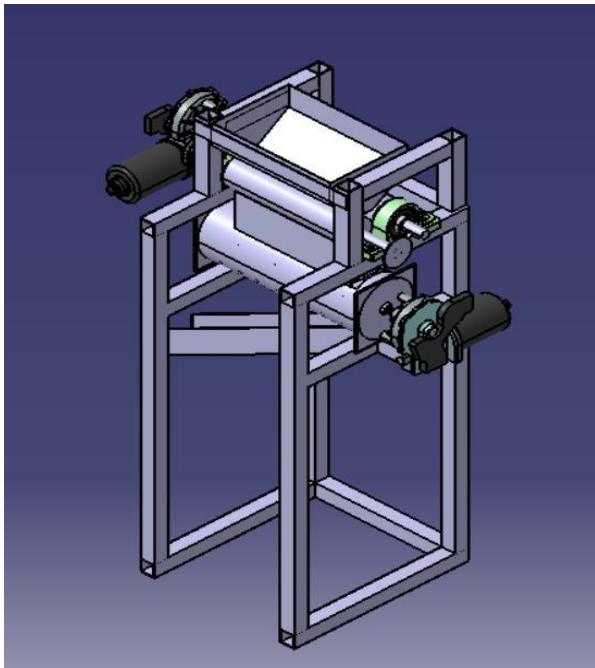

Fig no.1: Cad Model

## 7. STATISTIC STRUCTURAL ANALYSIS

Geometry

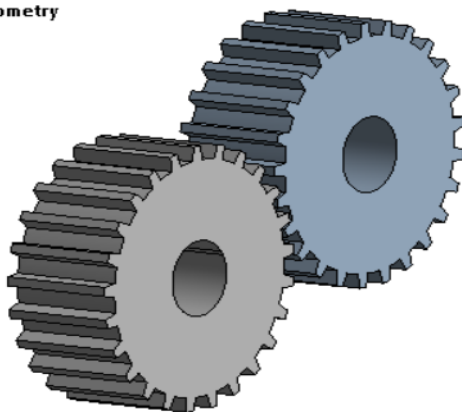

Fig no.2: Geometry after called into the ANSYS Software

Isotropic Elasticity	
Derive from	Young's Modulus and Poisson's Ratio
Young's Modulus	2e+11 Pa
Poisson's Ratio	0.3
Bulk Modulus	1.6667e+11 Pa
Shear Modulus	7.6923e+10 Pa
Isotropic Secant Coefficient of Thermal Expansion	1.2e-05 1/C
Compressive Ultimate Strength	0 Pa
Compressive Yield Strength	2.5e+08 Pa
Strain-Life Parameters	0.0e+01.0e+1-5.4e+0-6.6e-1
S-N Curve	log(10)1.0e+06.0e+0Pa log(10)7.9e+09.6e+0
Tensile Ultimate Strength	4.6e+08 Pa
Tensile Yield Strength	2.5e+08 Pa

Table-Properties of structural steel

## MESH

ANSYS Meshing is a general-purpose, intelligent, automated high-performance product. It produces the most appropriate mesh for accurate, efficient Multi physics solutions. A mesh well suited for a specific analysis can be generated with a single mouse click for all parts in a model. Full controls over the options used to generate the mesh are available for the expert user who wants to fine-tune it. The power of parallel processing is automatically used to reduce the time you have to wait for mesh generation. Creating the most appropriate mesh is the foundation of engineering simulations. ANSYS Meshing is aware of the type of solutions that will be used in the project and has the appropriate criteria to create the best suited mesh. ANSYS Meshing is automatically integrated with each solver within the ANSYS Workbench environment. For a quick analysis or for the new and infrequent user, a usable mesh can be created with one click of the mouse. ANSYS Meshing chooses the most appropriate options based on the analysis type and the geometry of the model. Especially convenient is the ability of ANSYS Meshing to automatically take advantage of the available cores in the computer to use parallel processing and thus significantly reduce the time to create a mesh. Parallel meshing is available without any additional cost or license requirements.

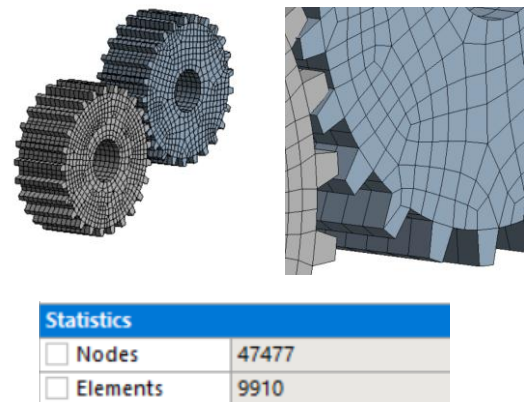

Fig no.3: meshing diagram

## Boundary Condition-

A boundary condition for the model is that the setting of a well-known value for a displacement or an associated load. For a specific node you'll be able to set either the load or the displacement but not each. The main kinds of loading obtainable in FEA include force, pressure and temperature. These may be applied to points, surfaces, edges, nodes and components or remotely offset from a feature.

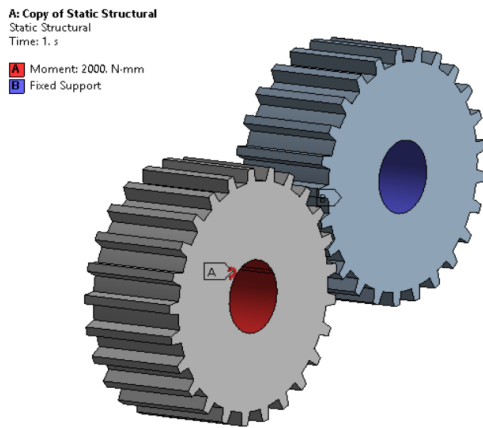

Fig no.4: boundary conditions

### EQUIVALENT STRESS

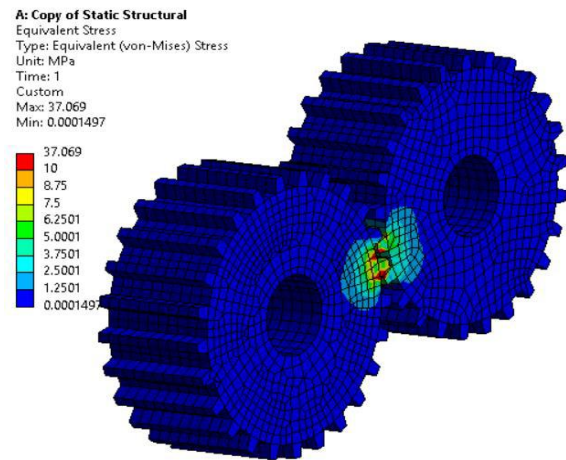

Fig no.6: stress on the gears

### RESULTS :

#### TOTAL DEFORMATION

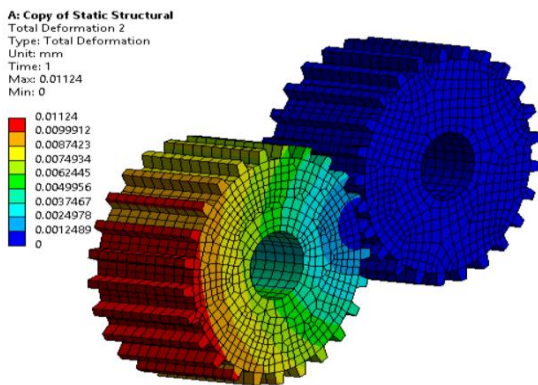

Fig no.5: total deformation diagram

Table – Total deformation

Results	
<input type="checkbox"/> Minimum	0. mm
<input type="checkbox"/> Maximum	1.124e-002 mm
<input type="checkbox"/> Average	3.3971e-003 mm

Table - stresses on gear

Results	
<input type="checkbox"/> Minimum	1.497e-004 MPa
<input type="checkbox"/> Maximum	37.069 MPa
<input type="checkbox"/> Average	0.48949 MPa

## 8. FABRICATION AND MANUFACTURING

### 8.1 Components

Following components were manufactured and fabricated for the project:

#### 8.1.1 Frame:

A framed structure in any material is one that is made stable by a skeleton that is able to stand by itself as a rigid structure without depending on floors or walls to resist deformation.

#### 8.1.2 Collecting Cylinder:

The capacity of a cylindrical box is basically equal to the volume of the cylinder involved. Thus, the volume of a three-dimensional shape is equal to the amount of space occupied by that shape.

#### 8.1.3 Rolling Mechanism:

The rolling mechanism is used to apply pressure on the tamarind seed here so that it would pop out from the tamarind fruit cover easily.

#### 8.1.4 Motors:

An electric motor is an electrical machine that converts electrical energy into mechanical energy. A pair of viper

motors are used in our machine for efficient working of the rolling mechanism

#### 8.1.5 Bearings:

Rolling bearings provide high precision and low friction and therefore enable high rotational speeds while reducing noise, heat, energy consumption and wear.

#### 8.1.6 Hopper:

Hoppers are used for the temporary storage of materials. They are designed so that stored material can be dumped or fed to a process easily.

### 8.2 Process Sheet:

Following operations were while fabricate the project

#### 8.2.1 Cutting:

Cutting is the separation or opening of a physical object, into two or more portions, through the application of an acutely directed force. Implements commonly used for cutting are the knife and saw, or in medicine and science the scalpel and microtome.

#### 8.2.2 Welding:

Welding is a fabrication or sculptural process that joins materials, usually metals or thermoplastics, by using high heat to melt the parts together and allowing them to cool causing fusion. Welding is distinct from lower temperature metal-joining techniques such as brazing and soldering, which do not melt the base metal.

#### 8.2.3 Drilling:

Drilling is a cutting process that uses a drill bit to cut a hole of circular cross-section in solid materials.

The drill bit is usually a rotary cutting tool, often multi-point.

#### 8.2.4 Finishing:

Finishing is a broad range of industrial processes that alter the surface of a manufactured item to achieve a certain property.

#### 8.2.5 Polishing:

Polishing is the process of creating a smooth and shiny surface by rubbing it or using a chemical action, leaving a surface with a significant specular reflection (still limited by the index of refraction of the material according to the Fresnel equations.) In some materials (such as metals, glasses, black or transparent stones), polishing is also able to reduce diffuse reflection to minimal values.

### 9. SAFETY PRECAUTIONS:

The following points should be considered for the safe operation of machine And to avoid accidents: -

- All the parts of the machine should be checked to be in perfect alignment.
- All the nuts and bolts should be perfectly tightened.
- The operating switch should be located at convenient distance from the operator so as to control the machine easily.
- The inspection and maintenance of the machine should be done from time to time.
- All the nuts and bolts should be perfectly tightened.

### 10. RESULTS:

The fabricated machine is designed for removing the 10kg Tamarind pods cover and seed per hour. The results of the trials are satisfactory for cover removal process. But there is further scope in development of same model for seed removal process. The modifications suggested above can be made so that the machine would show the result for tamarind seed separation very efficiently.

### 11. CONCLUSIONS

1. The design of the project was made according to calculations.
2. Static structural analysis was performed on most crucial part of the system ie. gear on which the whole crushing mechanism was based.
3. Hence, as a result we got maximum total deformation =  $<<0$  and maximum equivalent stress obtained was 37.069 MPa which falls under the yield point of the gear.
4. Hence, the design was considered to be safe and the manufacturing was done successfully.
5. The machine was tested and the purpose was successfully executed.

### ACKNOWLEDGEMENT:

I take this opportunity to express my sincere gratitude towards the Department of Mechanical Engineering, PES Modern College of Engineering Shivajinagar Pune, that gave me an opportunity for presentation of my Project Stage-I in their esteemed organization. I would like to express my sincere thanks to my Project guide Prof. C. K. Gosavi and Head of the Department Prof S. Y. Bhosale without whose guidance and adequate facilities. I would not have completed

my Project Stage-II, his valuable advice made it easy for me to proceed for this Project Stage-II. I express my sincere thanks to Project Co-Ordinator Prof. S. S. Darewar for his constant support and experienced guidance and providing me precious help and advice without which the successful completion of this Project Stage I would not have been possible. I am also thankful to Prof. Dr. Mrs. K. R. Joshi, PES Modern College of Engineering Shivajinagar Pune, for giving me necessary resources and support to complete my Project Stage-II. Last but not the least, I thank all others, and especially my classmates and my family members who in one way or another helped me in the successful completion of this work.

### References:

[1] Design and Fabrication of Tamarind Cover and Seed Separation Machine A.R.Lende, P.A.Chandak, tanuja.chandak@yahoo.com, pukharaj@rediffmail.com

[2] Identification of A Mechanism For Mechanical Deseeding Of Tamarind by Anagha Balan\*, Arathy Krishnan, Josna.K, Libina Stephen, Er. Shivaji. K. P.\*\* \*Department of Farm Power Machinery and Energy, K.C.A.E.T, Tavanur, Malappuram, Kerala-679573 \*\*Assistant Professor, Department of Farm Power Machinery and Energy, K.C.A.E.T, Tavanur, Malappuram, Kerala-679573

[3] Tamarind seed processing and by-products Arudra Srinivasa Rao<sup>1\*</sup>, Arudra Ashok Kumar<sup>2</sup>, Mapakshi Venkata Ramana<sup>3</sup> (1. Assistant Professor & Head, Dept. of Agro Energy, College of Agricultural Engineering, Madakasira, Andhra Pradesh, India; 2. Assistant Professor, Dept. of Farm Machinery & Power, College of Agricultural Engineering, Madakasira, Andhra Pradesh, India; 3. Associate Dean, College of Agricultural Engineering, Madakasira, Andhra Pradesh, India.)

[4] DEVELOPMENT AND EVALUATION OF A CONTINUOUS TYPE TAMARIND DESEEDER Paramasivan Karthickumar<sup>1</sup>, Narasingam Karpoora Sundara Pandian<sup>\*1</sup>, Perumal Rajkumar<sup>1</sup>, Allimuthu Surendrakumar<sup>2</sup>, Murugesan Balakrishnan<sup>1</sup> <sup>1</sup>Tamil Nadu Agricultural University, Department of Food and Agricultural Process Engineering, Coimbatore, India <sup>2</sup>Tamil Nadu Agricultural University, Agricultural Machinery Research Centre, Coimbatore, India.