

A REVIEW ON DESIGN AND 3D PRINTING OF A ROTOR BLADE OF LIGHT HELICOPTER

N.Yadagiri¹, V.Ajith Kumar², V.Rajesh³, R.Ravi Nayak⁴

¹ Assistant Professor, Department of Mechanical Engineering, Guru Nanak Institute of Technology, Ibrahimpatnam, R.R. Dist-501506, India

^{2,3,4} UG Student, Department of Mechanical Engineering, Guru Nanak Institute of Technology, Ibrahimpatnam, R.R. Dist-501506, India

Abstract -3D printing is an added substance fabricating process that can assemble protests straightforwardly from a computational model. Not in the smallest degree like standard social event methods, for example, dealing with and adornment, 3D printing can manufacture models of self-assured multifaceted nature in to some degree speedy time frames. It is an essential resource for envisioning complex human or animal life frameworks and can be used for cautious arrangement, specialist and patient tutoring, activity planning, clinical contraption prototyping, and redid clinical contraption fabricating.3D printing advancement is rapidly creating with advances in materials, objective, and speed hence making more noteworthy authenticity and higher exactness; this thusly empowers new clinical applications.

Helicopters are cutting edge flying wonders that utilizes huge rotating cutting edges to produce pushes. This push is utilized to lift the airplane in air and moves it in both forward and in reverse headings. Since every one of the significant capacities are accomplished with the principal rotor of the helicopter, so surveying the variable of wellbeing of the blade is required. From the start aviation enterprises are giving more significance to the designs. Since the design ought to be of incredibly low weight and it's ready to endure the huge number of burden cases. This paper presents the underlying examination of fundamental rotor sharp edge of a helicopter. To plan the rotor sharp edge with the contort point (0°, 7°, 8°,9°) .since the Angle of wind is assuming indispensable part if there should be an occurrence of strength and to builds the exhibition and to analyze the properties of composite materials like carbon/epoxy and glass/epoxy. To recreate the mechanical properties limited component strategy was utilized.

Keywords:3D printing ,Rotor Blade of light Helicopter.

1. INTRODUCTION

1.1 3D PRINTING TECHNOLOGY:

3D Printing also called as an Additive Manufacturing is a strategy for creating three layered strong items from a

computerized file.3D printing is an added substance process by which layers of material are moved toward empower a 3D part. This is the go against of subtractive assembling processes, where a last plan is cut from a bigger square of material. Accordingly, 3D printing empowers less material wastage. The making of a 3D printed object is accomplished utilizing the added substance process.

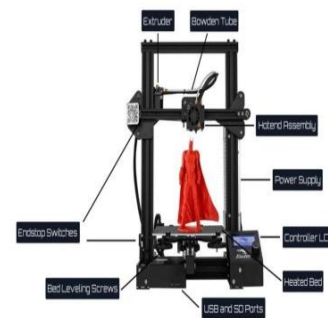

Fig-1: 3D printer

1.2 What Materials can be used in 3D Printing?

There are a scope of 3D printing materials, including thermoplastics like acrylonitrile butadiene styrene (ABS), metals (counting powders), gums and earthenware production.

1.3 Fused Deposition Modelling:

The communication starts with the stacking of the spool of thermoplastic fiber. These thermoplastic filaments (explained later in the article) are the material for FDM printing. This fiber goes to the extruder when the temperature of the print head shows up at the conditioning sign of the specific fiber. The temperature will fluctuate as indicated by the assurance of the materials in FDM 3D printers. You ought to have an arrangement arranged for printing. As demonstrated by the 3D arrangement, the print head moves in by and large around the different turn. By and by, as the ejection head is stacked with the broke down thermoplastic material, the declaration initializes with the

improvement of the removal head. One layer later the other, the material is put away as indicated by the 3D arrangement that has been inputted in the FDM 3D printer. Later each layer, the cooling of thermoplastic material happens using the cooling fans that are joined to the ejection head. Later each layer gets done, the structure stage drops down giving space for the accompanying layer oath.

1.3.1 FDM 3D Printing in Practice

FDM is more easy to understand than the other two techniques, and it has less working parts to battle with. It's moreover more sensible, making it the most renowned method for workspace 3D printers. As well as conveying a lower sticker price, the thermoplastic fibers are additionally naturally and precisely steady. Regardless, printing an article with FDM overall takes more time than printing a comparable thing using SLS or SLA, and the inevitable result will require some adjusting. FDM frequently creates objects with harsher surfaces.

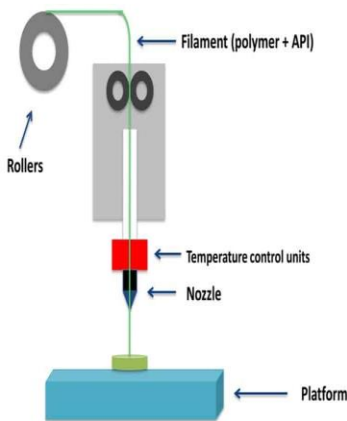

Fig -2: FDM machine

1.3.2 Printing

The powder is dispersed in a slight layer on top of a phase inside the structure chamber. The printer preheats the powder to a temperature somewhat under the conditioning spot of the crude substance, which simplifies it for the laser to raise the temperature of explicit locales of the powder bed as it follows the model to set a section. The laser really looks at a cross-part of the 3D model, warming the powder to just underneath or right at the dissolving point of the material. This breakers the particles together definitively to make serious areas of strength for one

1.3.3 Cooling

Following printing, the structure chamber requirements to hardly chill off inside the print fenced in region and afterward, by then, outside the printer to ensure ideal

mechanical properties and make an effort not to curve in parts.

1.3.4 Post-processing

The finished parts ought to be wiped out from the structure chamber, segregated, and cleaned of excess powder. The powder can be reused and the printed parts can be further post-dealt with by media affecting or media tumbling.

2. INTRODUCTION

2.1 ROTOR BLADE OF LIGHT HELICOPTER

A helicopter fundamental rotor or rotor framework is the blend of a few rotating wings (rotor edges) and a control framework that creates the streamlined lift force that upholds the heaviness of the helicopter, and the push that neutralizes streamlined haul in forward flight. Every primary rotor is mounted on an upward pole over the highest point of the helicopter, instead of a helicopter tail rotor, which associates through a mix of driveshafts and gearboxes along the tail boom. The sharp edge pitch is ordinarily constrained by swashplate associated with the helicopter flight controls.

2.2 Overview

The helicopter rotor is fuelled by the motor, through the transmission, to the turning pole. The pole is a tube shaped metal shaft that broadens vertically from — and is driven by — the transmission. At the highest point of the pole is the connection point (informally called a Jesus nut) for the rotor cutting edges called the center. The rotor edges are then connected to the center, and the center can have 10-20 times the drag of the blade. Main rotor frameworks are grouped by how the principal rotor edges are joined and move comparative with the fundamental rotor center point. There are three fundamental groupings: inflexible, semirigid, and completely expressed, albeit some advanced rotor frameworks utilize a blend of these characterizations. A rotor is a finely tuned turning mass, and different unobtrusive changes lessen vibrations at various airspeeds. The rotors are intended to work at a decent RPM (inside a limited scope of a couple percent), but a couple of trial airplane utilized variable speed rotors.

Not at all like the little breadth fans utilized in turbofan stream motors, the fundamental rotor on a helicopter has a huge measurement that allows it to speed up an enormous volume of air. This allows a lower downwash speed for a given measure of pushed. As it is more productive at low velocities to speed up a lot of air by a little degree than a modest quantity of air by an enormous degree, a low plate stacking (push per circle region) extraordinarily builds the airplane's energy proficiency, and this lessens the fuel use and allows sensible reach. The drift productivity ("figure of

legitimacy") of a regular helicopter is around 60%. The inward third length of a rotor cutting edge contributes very little to lift because of its low velocity.

2.3 Blades

The sharp edges of a helicopter are long, thin airfoils with a high angle proportion, a shape that limits haul from tip vortices (see the wings of a lightweight plane for correlation). They by and large contain a level of waste of time that lessens the lift created at the tips, where the wind current is quickest and vortex age would be a critical issue. Rotor cutting edges are made from different materials, including aluminum, composite design, and steel or titanium, with scraped area safeguards along the main edge.

Rotorcraft sharp edges are generally latent; nonetheless, a few helicopters remember dynamic parts for their edges. The Kaman K-MAX utilizes following edge folds for sharp edge pitch control and the Hiller YH-32 Hornet was controlled by ramjets mounted on the cutting edge closes. Starting around 2010, examination into dynamic cutting edge control through following edge folds is underway. Tips of some helicopter cutting edges can be uniquely intended to diminish disturbance and commotion and to give more proficient flying. An illustration of such tips are the tips of the BERP rotors made during the British Experimental Rotor Program.

A variety of the completely expressed framework is the delicate in plain rotor framework. This kind of rotor can be found on a few airplanes delivered by Bell Helicopter, like the OH-58D Kiowa Warrior. This framework is like the completely expressed type in that every sharp edge can lead/slack and chase autonomously of different cutting edges. The distinction between a completely expressed framework and delicate in-plane framework is that the delicate in-plane framework uses a composite burden. This burden is joined to the pole and goes through the cutting edge holds between the sharp edges and the shear bearing inside the grasp. This burden moves a development of one edge to another, typically restricting sharp edges. While this isn't completely expressed, the flight attributes are basically the same and support time and cost are decreased.

2.4 Rigid Rotor

The expression "inflexible rotor" typically alludes to a hingeless rotor framework with sharp edges deftly connected to the center point. Irv Culver of Lockheed created perhaps the earliest inflexible rotor, which was tried and created on a progression of helicopters during the 1960s and 1970s. In an unbending rotor framework, every sharp edge

folds and hauls about adaptable segments of the root. An unbending rotor framework is precisely less difficult than a completely expressed rotor framework. Loads from fluttering and lead/slack powers are obliged through rotor sharp edges flexing, as opposed to through pivots. By flexing, the actual edges make up for the powers that recently required rough pivots. The outcome is a rotor framework that has less slack in charge reaction in view of the huge center second normally generated. The inflexible rotor framework accordingly kills the risk of pole knocking innate in semirigid rotors.



Fig-3:Rigid Motor

The semirigid rotor can likewise be alluded to as a wavering or teeter-totter rotor. This framework is ordinarily made out of two edges that meet simply under a typical fluttering or wavering pivot at the rotor shaft. This permits the edges to fold together in inverse movements like a teeter-totter. This under slinging of the sharp edges beneath the wavering pivot, joined with a sufficient dihedral or coning point on the sharp edges, limits varieties in the span of every cutting edge's focal point of mass from the hub of revolution as the rotor turns, which thusly diminishes the weight on the sharp edges from lead and slack powers brought about by the Coriolis impact. Optional fluttering pivots may likewise be given to give adequate adaptability to limit skipping. Padding is achieved by the padding pivot at the cutting edge root, which permits changes to the pitch point of the cutting edge.

2.5 Combination

Current rotor frameworks might utilize the consolidated standards of the rotor frameworks referenced previously. Some rotor center points consolidate an adaptable center, which takes into consideration cutting edge twisting (flexing) without the requirement for orientation or pivots. These frameworks, called "flexures", are normally developed from composite material. Elastomeric heading may likewise be utilized instead of regular roller orientation. Elastomeric course are developed from an elastic kind material and give restricted development that is impeccably appropriate for helicopter applications. Flexures and elastomeric orientation require no grease and, hence, require less upkeep. They

likewise retain vibration, and that implies less weariness and longer help life for the helicopter parts.

2.6 Swash plate

Controls fluctuate the pitch of the principal rotor edges consistently all through revolution. The pilot utilizes this to control the bearing of the rotor push vector, which characterizes the piece of the rotor circle where the greatest push creates. Aggregate pitch changes the greatness of rotor push by expanding or diminishing push over the entire rotor plate simultaneously. These edge pitch varieties are constrained by shifting, raising, or bringing down the swash plate with the flight controls. By far most of helicopters keep a steady rotor speed (RPM) during flight, leaving the approach of the cutting edges as the sole method for changing push from the rotor.



3. LITERATURE SURVEY

The Dynamic Characteristics Analysis of Rotor Blade Based on ANSYS by Nian-zhao Jiang, Xiang-lin Ma, Zhi-qing Zhang, Those three-estimation compelled part show for helicopter rotor edge require been worked with APDL tongue, that point utilizing this model, those static quality and the segment qualities something like rotor edge require been investigated with ANSYS programming gathering.

Actuator configuration for those dynamic trailing edge of a helicopter rotor edge Toward Christoph k. Maucher¹, Boris An. Grohmann¹, subside Jänker¹, Andree Altmikus², Flemming Jensen³, horst Baier, Today, helicopters Indeed going currently white collar of the way beginning for their common impact review external noise, fuel use In addition emissions, their low passee comfort concerning lodge upheaval Moreover vibrations Additionally their confined execution for views flight envelope, speed Moreover degree. A champion around those basic wellsprings over upheaval Moreover vibrations may be the key rotor, especially completed fast propel likewise plummet flight. Therefore, developments to moved rotor control would investigate.

structural analysis of the main rotor blade for a light helicopter - case of hovering flight mode by diana cazangiu, in MAY 2014, in might 2014, those aviation industry arrangements starting with the start with structures with extraordinary necessities. Similarly as amazing lightweight Also withstanding with a huge number from claiming load situations.

Noise in helicopters is a major concern, from environmental impact to making enemies alarmed in military helicopters. It can even be a headache for passengers because of the continuous buzzing noise. In this experiment, spoilers attached to the trailing edge of the rotor blades are used to reduce the noise and vibration, thus increasing its efficiency. The rubber spoilers taken are of two types silicone and neoprene. The noise level (in dB) was measured using IR sensors. The rotor Blades with and without spoilers were measured. Both spoilers (silicone and neoprene rubber) resulted in the reduction of the noise level by several decibels compared to the one without spoilers. Fig 2 shows the proposed design of the helicopter. [1]

Vibration is obvious to nearly all aspects of chopper operation, including fatigue of aviators and to its structural integrity. The vibration characteristics of rotating shafts vary from that of nonrotating shafts due to coupling of elastic distortion and rigid body stir. A dynamic stiffness system was used to determine the vibration characteristics for rotating ray. Vibration characteristics of a multibody system similar as a mortal body, robots, spacecraft, and vehicles can be modelled. The styles to study vibration

characteristics of mechanical system are substantially finite element system (FEM), structural modal conflation, and modal analysis. Flap wise climate of copter rotor blades differ from those of other slender shafts because of centrifugal force fields.[2]

The blade pre-twist has been studied considerably and extensively employed in rotor blade design to achieve better performance in hang and further flight. The effect of dynamic blade shape approaches including airfoil morphing, blade twist, variable rotor speed and variable rotor compass on copter rotor performance have been studied. The most representative study is the ATR, which has tested hang and further flight to demonstrate vibration and noise reduction using open- circle and unrestricted- circle control. Other studies use multi-harmonic actuation that consists of variety control factors. To negotiate active twist rotor in field. Fig.3 Two-piece blade concept of PLTC [3]

Numerous engineering operations have rotor- blade systems as their main element, for which active control has been an engaging approach to upgrade performance and suppress climate. Passive damping methods aren't suitable to attain advanced effectiveness in a two-dimensional system whose dynamics is periodic. Utmost of the results available in the literature are based on direct time in variant analysis and mixture ways. The rotor- blade system under investigation is a four-blade rotor with tip masses, rotating in a suspended axis. [4]

The main comfort issues affecting passenger comfort in a turboprop aircraft fuselage are the propeller tonal noise and the affiliated climate. The main noise sources during flight are generated by the propeller's rotational angular velocity,

number of blades, power at shaft generating aircraft thrust, and blade configuration. An innovative tolerating bi-tonal device able to optimize the fuselage noise reduction at two different flight administrations has been designed and numerically certified. Due to specific marketable needs, the use of bi-tuned frequency can lead to an unresisting noise reduction with two RPM administrations: 100 at take-off, rise, and approach, and 86 during the cruise, rising, and descent. The vibration of the fuselage of a turboprop aircraft can be tuned at two different frequencies to reduce noise with respect to two different flight administrations. For the two propeller tones, reductions of 32.8 dB and 27.9 dB have been estimated for the two vibration situations. Primary results from this stage encourage the advancement of the disquisition. This paper deals with the design and numerical simulations of a new unresistant bi-tonal device suitable to be tuned at two different frequencies to reduce the fuselage noise with respect to two different flight administrations.[5] A helicopter main rotor or rotor system is the combination of a rotary-wing and a control system that generates the aerodynamic lift force that supports the weight of the helo and the thrust that counteracts aerodynamic drag in forward flight. An Active Twist Rotor (ATR) is being developed for the coming implementation of individual blade control for vibration and noise reduction in helos. The rotor blade is integrally twisted by direct strain actuation using active fibre mixes (AFC). 3D models are designed and broken down in CATIA and Ansys. Juan de la Cierva's rotor blade is the basis of the most multi-bladed helo rotor systems. Arthur Young's stabiliser bar was used in several Bell and Hiller chopper models in the 1930s. Alphonse Pénard's coaxial rotor model chopper toys inspired the Wright brothers to dream of flight. [6] For a given machine power and RPM input, the most fruitful area for enhancement in effectiveness by propeller design is a reduction in energy losses. The simple ways to increase the effectiveness are the reduction of blade area, adding cargo near the tip, and taking up a larger periphery with low RPM. Vibration and noise will be the first issues when a developer tries to refine the effectiveness of the propeller. In conclusion, it can be said that the NPT design procedure has been extended to take account of the commerce between the propeller and the housing. A simple system has been developed which can reliably predict pressure impulse situations for different propeller shapes and housing forms during the design process.[7]

Aeroacoustics rotor simulations are based on aerodynamic and aeroelastic tools able to foretell the wake-blade miss distance, which plays a key part in the blade-whirlpool interaction noise discharge. The control law is linked through a numerically effective aeroacoustics solver grounded on logical-numeric sectional aerodynamics modelling. Its revision is the main ideal of the proposed regulatory action. It's grounded in an optimal, multicycle, control approach that exploits distributed torque loads actuated by smart materials to twist rotor blades at the 2/rev frequency (active twist rotor conception). Eventually,

the effectiveness of the proposed low-frequency feedback control law for blade-whirlpool commerce noise relief is assessed by the operation of the helo rotor in descent flight. They've developed a control algorithm grounded in ATR control law aimed at reducing copter rotor noise. The proposed noise control methodology seems to be a good candidate for rotor noise relief in real copter flight operations.[8]

For a design detail with given machine power and RPM input, the most fruitful area for enhancement in effectiveness by propeller design is a reduction in energy losses. The simple way to increase the effectiveness is reduction of blade area, adding cargo near the tip and espousing a larger periphery with low RPM. In the last many times orders for over 150 NPT propellers have been secured by SMP, substantially for Far Eastern ockyards, with numerous vessels fated for Western possessors. One intriguing specific of the NPT design was that the relinquishment of the new profile family reduced the optimum periphery below that of the optimum periphery of conventional propellers designed for the same installation. This involves incorporating the housing and propeller commerce factors into the boat design process at an early stage. To completely exploit the eventuality for bettered overall effectiveness and reduced excitation forces the NPT design system was expanded into a further holistic approach where relations with the housing and goods on the housing were considered at an early stage in the propeller design process.[9]

4. DESIGN OF ROTOR BLADES OF A LIGHT HELICOPTER

Accomplishing genuinely low greatest lift coefficients. The goeey drag part, addressed around by the coefficient C_{d0} , limited via cautiously controlling the airfoil pressure dispersion and expanding the harmony wise degree of laminar stream, essentially for a scope of low to direct lift coefficients. Additionally, natural variables will more often than not produce bug accumulation and sharp edge disintegration at the sharp edge driving edge, which can cause untimely limit layer progress and decrease the run of laminar stream anyway. In certain conditions surface harshness can antagonistically adjust different parts of the airfoil qualities, for example, by bringing down C_{lmax} and changing the slow down attributes. A strong boundary influencing the profile force of the rotor is the airfoil thickness. Utilizing 2-D airfoil estimations given by Abbott and Von Doenhoff 1949, the zero-lift sectional drag coefficient for NACA 0012 symmetric series can be approximated by the situation.

Main Rotor Blade dimensions

Rotor Diameter = 25ft 2 in

Blade Chord (width) = 7.2 in

Blade Twist = 80

Tip Speed at 100 % RPM = 672 ft/s (458mph)

Profile Blade

NACA-0012

Maximum camber (%) = first digit 0 to 9.5 %

Maximum Camber position (%) = second digit 0 to 90 %

Thickness (%) = 1.2 (Third and Fourth digits 1 to 40 %)

Thickness Distribution

$$y_t = T/0.2 (a_0x + a_1x^2 + a_3x^3 + a_4x^4)$$

$$a_0 = 0.2969$$

$$a_1 = -0.126$$

$$a_3 = 0.2843$$

$$a_4 = -0.105 \text{ (or) } -0.1036$$

Where T/0.2 is to adjust the count required thickness a0 to a4

for 20% thickness airfoil At the trailing edge (x=1) there is finite thickness of 0.0021 chord width for a 20% airfoil.

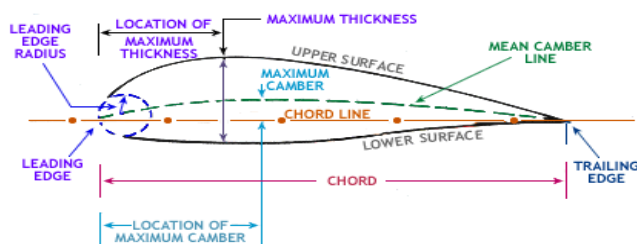

Fig-5: Structure parameters

$$Cd_0 = 0.007 + (t/c)$$

Where t/c is the thickness-to-chord ratio

The outcome is substantial in the reach $0.06 \leq t/c \leq 0.24$. The impacts of Mach number compound the way of behaving of the drag, yet at moderate approaches underneath the drag difference Mach numbers the impacts of compressibility are little and are greater aversion to Reynolds numbers. Accept, for instance that an edge tightens in thickness from an airfoil with a 12% thickness-to-harmony proportion at root to a 8% proportion at the tip. Thusly, utilizing above Equation the drag coefficient can be composed as

$Cd_0(r) = 0.007 + 0.025(0.12 - 0.04r) = 0.01 - 0.001r$ The profile power coefficient can now be assessed utilizing the cutting edge component model where $Cp_0 = \frac{1}{2} \sigma \int_0^1 cd_0 r^3 dr = \frac{1}{2} \sigma \int_0^1 (0.01 - 0.001r) r^3 dr$. A 8% decrease in profile power without utilization of thickness variety. Rotor power or shaft force, this would offer a 0.5-1.5% increment in by and large vertical lifting capacity,

The Value y_t is a half thickness and necessities to applied both side of the camber line utilizing the condition both side of the camber line utilizing the condition above for a given worth of a. it is feasible to compute the camber line position y_c the inclination of camber line and the thickness The place of the Upper and Lower surface can be determined oppositely to the camber line $\theta = \tan(dy/dx)$

Upper surface : $x_4 = x_c - y_c \sin(\theta)$

$$Y_4 = y_c + y_t \cos(\theta)$$

Lower surface : $x_1 = x_c + y_c \cos(\theta)$

$$Y_1 = y_c - y_t \sin(\theta)$$

After substituting all the value we get symmetrical airfoil as shown fig below

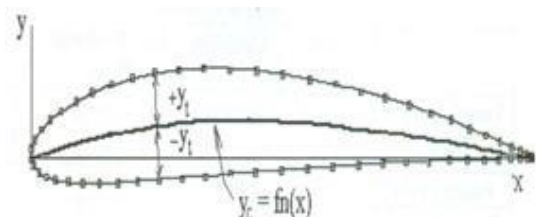

Fig-6:Coordinates of Blade

CATIA SKETCHES

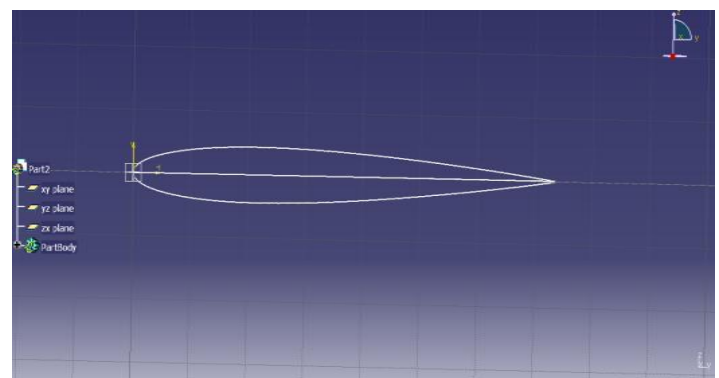

Fig-7: Outline of Design (step-1)

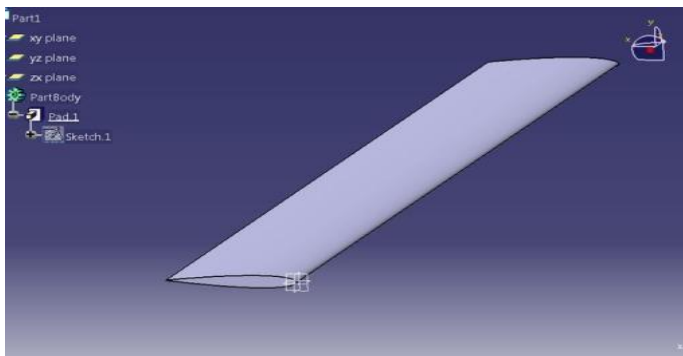

Fig-8: Step-2

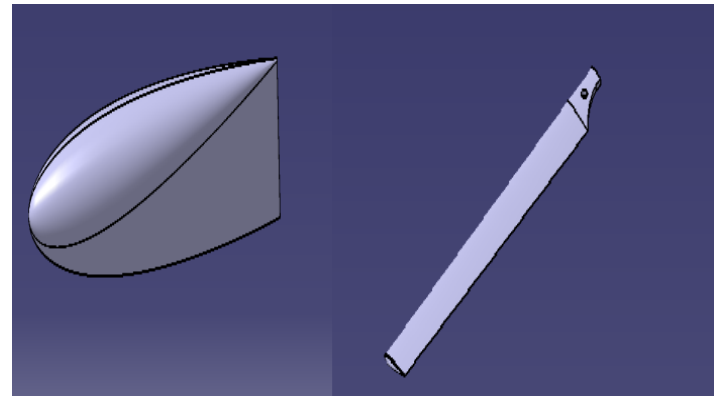

Fig-12: Rotor Blade (Step-6)

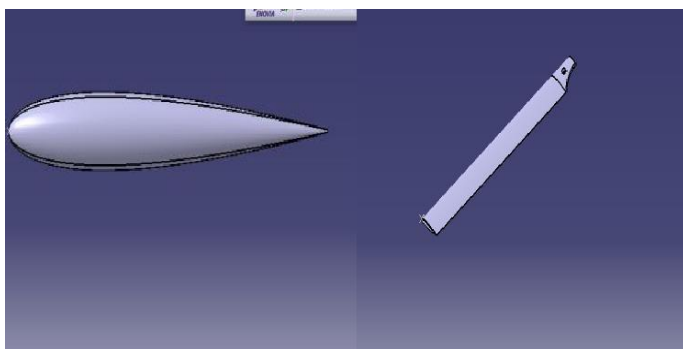

Fig-9: Step-3

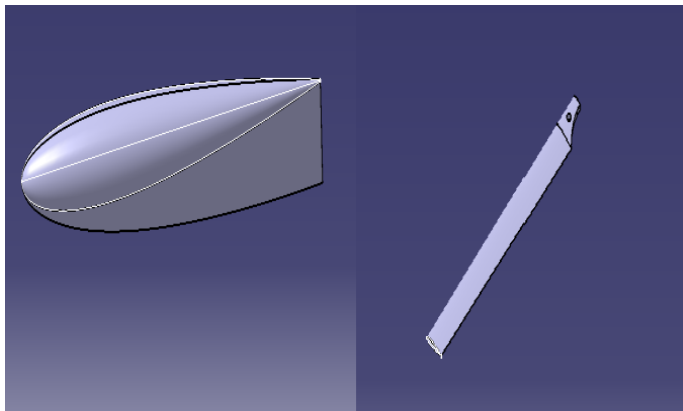

Fig-10: Step-4

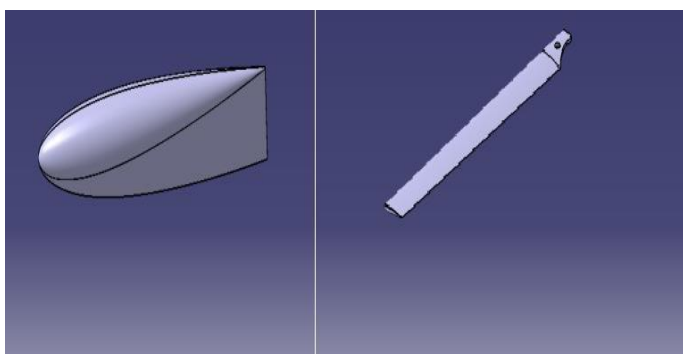

Fig-11: Step-5

5. CONCLUSIONS

We studied on the frameworks which are utilized in light helicopter. This helicopter can be utilized for rescue vehicle job, common Purpose, slide variations, wheeled variations, calamity help tasks, Offshore Operations, outfitted job, coast monitor job, high elevation activities. We planned the rotor cutting edge of a light helicopter utilizing CATIAV5.

REFERENCES

- [1] <https://www.economist.com/technologyquarterly/2013/09/05/3d-printingscales-up>
<https://wohlerassociates.com/additivemanufacturing.html>
- [2] Brogan Rylands, 3D Printing - To print or not to print? Aspects to consider before adoption - A supply chain perspective in the year 2015.
- [3] ALEXANDER Pirjan and Dane-Mihaela Petrosanu, The impact of 3D Printing technology the society and economy
- [4] Vinod G. Gokhare, A review paper on 3D Printing aspects and various processes used in 3D-Printing, volume 6, issue 6 in June 2017, ISSN 2278-0181
- [5] Hawking iw; iHan, iKS- "Design and Assessment of Multi Leaf Spring," International Journal of Research in Aeronautical and Mechanical Engineering, vol. 1, no. 7, p. 20, 2013.
- [6] MD Tahsin Ishimaru & Sung Hwan Jo- "Design and Analysis of automobile leaf spring using ANSYS," International Journal of Mechanical and Industrial Engineering, vol. 2, no. 1, pp. 97-100, 2012.
- [7] T. N. V. Kumar, E. Rao, and S. V. Krishna, "Design Material Optimization of Heavy Vehicle Leaf Spring," International Journal of Research in Mechanical Engineering and Technology, vol.