

# AUTOMATIC RUBBER TAPPING MACHINE

Samson P Mathew<sup>1</sup>, Nidhinkrishna R<sup>2</sup>, Ananthu krishnan<sup>3</sup>, Er. Chinn Mohanan<sup>4</sup>

<sup>1-3</sup> Students, Dept. of Electronics and Communication Engineering, Saintgits College of Engineering, Kerala, India

<sup>4</sup> Assistant Professor, Dept. of Electronics Engineering, Saintgits College of Engineering, Kerala, India

\*\*\*

**Abstract** - Rubber tapping is the process of extracting latex from rubber trees. Tapping rubber trees is considered a skill-based activity. During the tapping, the taper must make a downward, half-spiral cut in the bark to extract a white milky liquid called latex. On a typical day, a rubber tapper must manually dig about 500 to 800 rubber trees with a tapping tool at a given time of day. Skilled workers who can handle this daunting task are increasingly scarce. Although cheap unskilled labor is available, they can damage trees without time and training. The automatic rubber tapping machine designed here will replace the labor required for the tapping process. In addition, the timing of the tapping process can be controlled by a clock function, thereby increasing the yield of latex.

**Key Words:** Rubber, Automatic, Tapping, Extract, Manually, Machine.

## 1. INTRODUCTION

Rubber is a plantation crop that is drastically grown in southern India. There exists a massive majority of rubber cultivators in Karnataka and Kerala. The rubber plant isn't a local Plant of India. Dutch colonialists who also cultivated rubber of their plantations in Indonesia delivered the rubber plant to Kerala, India; due to its comparable tropical climate. Rubber is a financial crop. The rubber plant produces sticky, white latex that is amassed and processed to produce natural rubber. Natural rubber is an elastomer that have become within the beginning derived from latex, a milky colloid created from *Hevea Brasiliense* or Rubber Tree. A rubber plant has to develop for about seven years before it may be harvested on a regular basis. A rubber tree can produce latex for over 25 years from at the same time as it's miles first tapped. Rubber tree have straight trunks and smooth green leaves. The tree would be 'tapped', that is, an incision is made into the bark of the tree. The latex from within the tree seeps to the surface of the cut and trickles down the reduce into a container, tied to the trunk of the tree. This rubber latex is harvested from wooden through "rubber tapping". The tree bark on the inner side contains layers of vessels referred to as lactiferous vessels. This includes the rubber latex. A cut is to be made into layer that includes those vessels to extract the latex. This residue of vessels may be very close to the Cambium layer of the rubber tree. During the tapping technique care need to be taken as to avoid the blade in the tapering tool to move deep into the bark and damage the cambium. If the cambium is damaged, the

broken place will form bulged uneven surface. The damaged cambium makes the tree liable to microbial assaults, which in worst case should kill the tree. A downward half spiral cut is made in the tree, about four feet from the ground and Circling approximately half of the tree. The latex flows down the spiral into the cup. It usually takes approximately to 3 hours earlier than the sap hardens and closes the cut in the tree. The coagulating time is greatly dependent on the temperature of the surrounding area. Every morning the rubber tapper empties the latex collected in the collecting cup located beneath the cut from every tree. Then the use of the tool gets rid of a skinny layer of the bark simply above the previous cut, through the cut the latex begins dripping into the collecting cup. A Usual rubber tree yields rubber latex for about 25 years, and then the rubber tree will Stop producing latex. The tree is then cut and used for commercial programs. A brand-new Rubber sapling is planted to take its location. The milk coloured latex sap collected is refined into usable rubber. The purified form of natural rubber is chemical polyisoprene, which can also be produced synthetically. Natural rubber has an extensive variety of applications as compared to artificial rubber. Natural rubber is utilized in insulating blankets and footwear. It is utilized in treads of car tires and conveyor belts due to its resistance to abrasion. The flexibility and elasticity of rubber makes it appropriate for hoses, shock absorbers, and as mountings for heavy machinery which reduces the vibrations. Rubber is especially water resistant. Because of its resistance towards water, it has a variety of applications in rainwear, diving and underwater system, additionally as a lining to a variety of Chemical and water tanks. Rubber being a bad conductor of strength is utilized in electrical Industry to apply as an insulating material.

## 2. OBJECTIVE

The rubber planters are facing severe shortage in the availability of rubber tapping workers. In the near future, the world is going to face a great shortage of skilled labors. Considering these problems, engineers around the world are trying to develop alternative methods of rubber tapping and to make the tapping process more efficient. But so far no good design has been brought up, the tapping industry is still on the same traditional path. After studying the various types of tapping and other necessary informations, we came up with a design for rubber tapping machine. This can also help the unskilled to do the tapping operation and expected to make a change in the field of rubber tapping.

### 3. METHODOLOGY

#### 3.1 Design

The device is implemented in such a way that it can automatically tap the bark of a rubber tree from one point to the other in an inclined path. For this the system has two parts, one part is tightly attached to the rubber tree and the other part is sliding over this tightly attached part. The part which is attached to the rubber tree consists of two metallic semicircular like structure which is vertically aligned and both are separated by two metallic rods at about 75cm distance apart. The semi-circular structure is designed in such a way that it provides a path for two wheels to slide over its top and bottom surfaces. The path is like a semi-circular cavity so that a wheel can easily slide through the cavity.

The other part of the device is the moving part, which is like an I-shaped structure, which is attached to the fixed semi-circular structure that is attached on the tree. There are six wheels attached to the I-shaped moving part in such a way that three wheels at the top and three wheels at the bottom. Those three wheels are arranged in a way that the top part has two wheels aligned face to face on the left side so that when attached to the semi-circular part these wheels will immersed inside the cavity thereby providing easy movement of the structure on the semi-circular path. While the right side contains only one wheel which is immersed into the cavity and a 100rpm gear motor which is provided to move the whole I-shaped structure through the semi-circular path. The motor will drive the moving part in such a way that the motor shaft contains a small gear at its end, so that, the gear will rotate on the semi-circular rack, fixed on the outer surface of the semi-circular structure, like a rack and pinion mechanism. In this way the horizontal movement of the structure is made possible. The above-mentioned arrangement of wheels and gear motor is also provided in the bottom part of the I-shaped structure.

The I-shaped moving part also contains the cutting part which moves vertically through the I-shaped structure. The cutting part consist of a circular disk having sharp edges projecting towards the tree surface. This circular disk is attached to a 10rpm gear motor so that the rotation of the motor helps the cutting disk to slice the bark of the tree. To obtain an inclined cut, along with the earlier mentioned horizontal motion a vertical movement of the cutting blade is also made possible by providing a threaded screw vertically parallel to I-shaped structure. The threaded screw is attached to the I-shaped structure in such a way that one end of the screw is attached to a 60rpm gear motor shaft and the other end is connected to a ball bearing. The metallic nut fixed on the cutting part will then move through the threaded screw carrying the cutting part when the threaded screw is rotated with the above mentioned 60 rpm gear

motor. In this way the vertical motion of the cutting blade is made possible.

Apart from this for analysing the position of the moving part on the semi-circular path we have provided two IR sensors on both ends of the I-shaped structure. Based on its reading the system can able to analyse whether the I-shaped structure has reached the end point or not and also which end point it is.

#### 3.2 Block Diagram

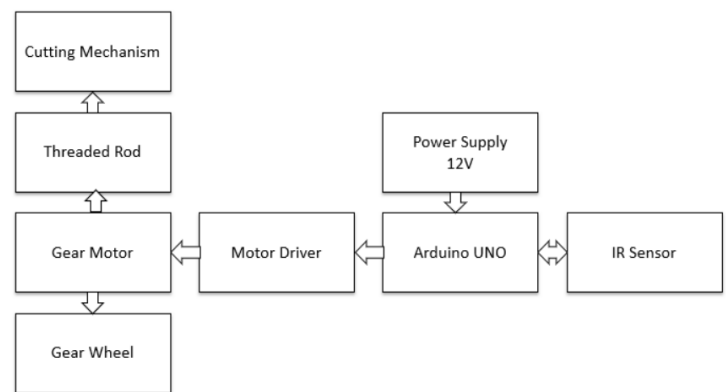

Fig -1: Block diagram of the proposed system

#### 3.3 Working

The system functions in such a way that when we switch on the system, the IR sensor will provide a reading showing that the system is at the starting position. After detecting that reading the I-shaped structure will then move from the starting point to the other end through the semi-circular path. Along with that motion, vertical motion of the cutting part is also undergoing through the rotation of the threaded rod which we have discussed earlier. Simultaneously, the cutting blade is rotating by the rotation of the gear motor attached to it. Hence, an inclined incision can be made possible on the tree surface. When it reaches the other end, the IR sensor will give a reading showing that the it has reached the end point. The system will then start moving to the initial point. While moving to the initial point, all the above-mentioned motors will rotate in opposite direction. When it reaches the initial point, the IR sensor will give a corresponding reading showing that it has reached the end point. When it reaches that point, the system will stop all its motors except the motor connected to the threaded screw in order to position the blade a few centimeters below the previous cut. For position the blade, the gear motor will rotate only one rotation after reaching the initial point. After that the system stops.

#### 4. RESULTS & DISCUSSIONS

The proposed model of the rubber tapping system was constructed in such a way that it performs the tapping process automatically. The system consists of two parts, one part is a semi-circular structure with geared teeth, which is tightly attached to the rubber tree and the other part is a moving part which consist of the cutting blade. The cutting blade was attached to an I-shaped structure with 6 wheels and 2 motors attached for the smooth movement of the structure along the tightly attached part. The 3D model of the I-shaped structure is shown in Fig-2.

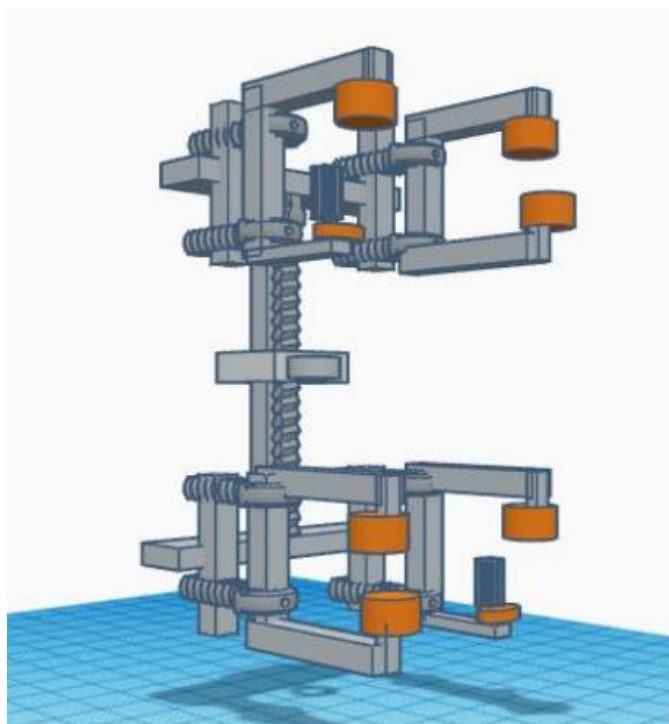

**Fig -2:** 3D model of I-shaped structure

In order to achieve an inclined cutting on the tree surface, the vertical and horizontal motion of the cutting blade was actualized by providing a threaded screw attached vertically parallel to the I-shaped structure and by the horizontal motion of the I-shaped structure along the semi-circular path. The cutting mechanism of the system is shown in Fig 3. Apart from the moving part of the system, two IR sensors were attached to both the ends of the I-shaped structure, in order to obtain the position of the cutting blade. The Arduino Uno was used for the control operation of the system. The table shows the readings from the IR sensor and the motion of the I-shaped structure.

IR Sensor-1	IR Sensor-2	Temporary Value (x)	Direction of motion
0	1	1	Towards Left
1	0	0	Towards Right
0	0	1/0	According to the value of x
1	1	1/0	

**Table-1:** IR sensor readings



**Fig -3:** Automatic Rubber tapping system & Tapped pattern

The fig-3 shows the incision made by the cutting blade on the tree surface. The incision is made on the tree surface through the rotation of the cutting blade on the tree surface. The cutting mechanism consist of a suspension system which presses the blade towards the tree surface thus providing a sufficient force for peeling the bark. Through this mechanism, the device will make an incision at a depth of about 3mm on the bark of the tree.

#### 5. CONCLUSIONS

Currently the agricultural sector is facing the worst shortage of skilled labours than any other sector in the world. As famers are the backbone of our nation, proper tools to be supplied to them in order to overcome the obstacles that are hindering the yield of their farming, is very important. The only solution for this is to introduce economically balanced technologies in those areas.

The " Automatic Rubber Tapping Machine" designed here is one such application of technology in the field of rubber tapping where it requires highly skilled labours. It simplify

and automate the entire rubber tapping process. The proposed vision will be a milestone in the ongoing research and development in the field of rubber tapping.

## REFERENCES

- [1] Chunlong Zhang, Liyun Yong, Ying Chen, Shunlu Zhang, Luzhen Ge, Song Wang and Wei Li (2019), "A Rubber-Tapping Robot Forest Navigation and Information Collection System Based on 2D LiDAR and a Gyroscope", College of Engineering China Agricultural University.
- [2] Y.A.I. Yatawara, W.H.C. Brito, M.S.S. Perera and D.N. Balasuriya,(2019) "Appuhamy- The Fully Automatic Rubber Tapping Machine", The Institution of Engineering Sri Lanka.
- [3] R Nair Arjun, Susan John Soumya, Rajendran S. Vishnu and Rao R Bhavani, (2016) "Semi Automatic Rubber Tree Tapping Machine" AMMACHI Labs, Amrita Vishwa Vidyapeetham, Amritapuri campus, Kerala, India.
- [4] S. R. Deepthi, R. M. D. DSouza and K. A. Shri, "Automated Rubber tree tapping and latex mixing machine for quality production of natural rubber," 2020 IEEE-HYDCON, 2020, pp. 1-4, doi: 10.1109/HYDCON48903.2020.9242699.
- [5] Zhang, Shunlu & Zhang, C. & Zhang, J. & Yuan, T. & Li, W. & Wang, Dashuai & Zhang, F.. (2018)."Design and experiment of suspension-typed rubber tapping device",International Agricultural Engineering Journal. 27. 110-118.
- [6] Zhao, Zhi-Min & Jin, Xiao-Dong & Zhang, Lin & Yu, Xiao-Lei. (2010). "A novel measurement system for dry rubber content in concentrated natural latex based on annular photoelectric sensor". International Journal of Physical Sciences. 5. 251-260.
- [7] Zhou, H., Zhang, S., Zhang, J., Zhang, C., Wang, S., Zhai, Y., & Li, W. (2021). "Design, development, and field evaluation of a rubber tapping robot". Journal of Field Robotics, 1- 27. <https://doi.org/10.1002/rob.22036>.