

# Smart Intrusion Detection System for Crop Protection

Atharva Mane, Ameya Mane, Parag Dhake, Prof. Mrs. Swati Kale

\*\*\*

## Abstract -

Agriculture continues to be one of India's most important economic sectors. It is critical for both human existence and economic growth. Even today, traditional systems such as humanoid scarecrows are used in agricultural fields to keep birds and animals from disturbing and consuming growing crops. Because such notions have numerous flaws, improving agricultural security has become a key concern in recent years. As a result, this paper focuses on presenting a system that detects intruders, monitors any malicious activity, and then reports it to the system's owner. It functions as an adjustable system that offers farmers with a practical technique for ensuring the complete protection of their farmlands from any threats or trespassing actions.

## 1. INTRODUCTION

Agriculture the golden word without which we cannot renew food resources. But only creating resources is not enough because if destroyed before getting the final output it's waste of time and money and the raw products. So protecting agricultural resources or farms is very important because animal intrusion in farms is becoming a serious conflict nowadays. Wild boars, macaques, porcupines, deer, monkeys, and bears are exceedingly destructive and have occasionally resulted in human deaths. Farmers growing at the local level lose up to 50% of their crops to wild animals, and they are unable to take any drastic steps due to tight wild life rules. The most common in many places are Human-elephant conflict which causes most of the damage in many areas. There are three levels of warnings in this system: low, moderate, and high, which allow the extent of threat posed by the intruder to be easily determined. The Passive Infrared (PIR) sensor is positioned in such a way that it provides a broader detection range. Information is transmitted to farmers via the Global System for Mobile Communications (GSM) module. The paper flow is as follows: in 2<sup>nd</sup> chapter is all about survey from various research papers. 3<sup>rd</sup> chapter specifies problem statement followed by 4<sup>th</sup> chapter i.e., present system and then 5<sup>th</sup> chapter hardware design after that 6<sup>th</sup> chapter is about objective and scope followed by result, discussion, conclusion and future scope in chapter 9, 10, 11 and 12 respectively.

## 2. LITERATURE SURVEY

The authors S. Yadahalli et al. used Arduino based intrusion detection system which consists of TFT display [1]. The authors A. V. Deorankar and A. A. Rohankar proposed "the study of current researches, the problems it addressed, and its prospects. The emphasis is focused on the analytical study of various advanced and efficient classification mechanisms and techniques. Proper utilization of the number of features of remotely sensed data and selecting the best suitable classifier are most important for improving the accuracy of the classification. The knowledge based classification or Non-parametric classifiers like decision tree classifier or neural network have gained more popularity for multisource data classification in recent times"[2]. The authors P. S. Dhake et al. built an Embedded surveillance system using PIR sensors which made us incline towards use of PIR sensor[3]. The authors R. Vingeshwar et al. developed a system elephant intrusion detection system in forest border areas using IoT[4]. The authors R. Nikhil Developed a real time monitoring of agricultural land and animal intrusion prevention using edge[5].

## 3. PROBLEM STATEMENT

Developing a system to detect an intruder without human intervention which can be installed in farmlands which lacks physical security or manual security.

## 4. PRESENT SYSTEM

The current system mostly functions as a surveillance system in farms. The most important thing that should be taken into consideration that this system does give the assurance to create a barrier or to act as a physical barrier between the farm and the wild animals. The existing or the displayed system also needs to take into consideration that all the animals are different in size. According to the threat level provided by animals crossing or trespassing on farmland, appropriate precautions must be adopted to prevent animals from entering the restricted area. Many crop protection systems exist, but intrusion detection is rarely one of them.

Farmers also use conventional measures like as scarecrows, which are ineffective in keeping wild animals and birds away, despite being simple to set up and effective in preventing bird ingress to some extent. They also use electric fencing, which has no channel for fast alerting of breaches occurring, and diagnosing problems is difficult and can be lethal at times. They are also quite expensive, with substantial maintenance costs. Some other measures used by farmers to avoid intrusion of wild animals are erecting physical barriers, manual inspection which is quite exhaustive.

Many of those system may also harm animals which may lead to violation of wildlife laws. As a result, the paper hopes to overcome those constraints.

## 5. HARDWARE DESIGN

The RaspberryPi-3 is a 64-bit microprocessor with strong performance and low power consumption. The RaspberryPi is the system's key component. PIR sensors, ultrasonic sensors, camera, GSM module, and buzzers are some of the other significant components of the system. PIR sensors detect motion whereas ultrasonic sensors detect objects. Based on the levels of infrared radiation detected, the PIR sensors detect motion. They are suited for use in the proposed system due to their low power requirements, small size, durability, and ease of use. Once the sensor has become used to its surroundings, or calibrated then any changes in the infrared radiation level shall make the PIR sensor go high. In the proposed system the camera used is a webcam which has High sensitivity for low light operation, low voltage, and steady colour photos captures adequate images in any light condition. All this setup also includes GSM module which is suitable for communication and can transfer data in the form of text and audio format. As a result, data transmission, real-time updates, and bandwidth conversion concerns have been rectified. Buzzers are included in addition to security cameras to sound an alarm when intruders are detected, either to scare the burglar away or to inform nearby persons of the incursion. And the whole setup also includes a monitor display to refer the images captured by the camera.

## 6. OBJECTIVES AND SCOPE

The system's methodology attempts to create a secure system for protecting farmlands against intruders such as wild animals and humans, sometimes without human participation. The GSM module is used as an additional security feature that sends an email to the owner if an

intruder is discovered. Also for the farmer to know better about the intrusion system contains a camera which continuously surveils the area and captures the images whenever the movement of any intruder is sensed by the sensors, and those images can be displayed on the monitor display. At night the flashlight allows the camera to capture an almost readable or understandable pictures.

## 7. RECOMMENDED SYSTEM

The system is built around a Raspberry Pi microcontroller, which serves as its brain. The board is connected to all of the sensors and cameras. The PIR sensors are designed to detect motion within a 5 meter range. When motion is detected in the vicinity, the PIR sensors activate and the camera is turned on. The camera will take a picture of the intruder, which may be viewed on the monitor that is linked. Following that, an auto-generated message alerting the owner of the intrusion will be sent automatically to the owner using the registered email address and the GSM module in text format. The farmer can activate and deactivate the system according to his or her needs, ensuring complete farm protection. The Passive Infrared Sensors (PIR Sensors) installed are used to detect motion of the intruder which activates the camera as well as notify the owner about the intrusion in his land. And this information or the captured image of the intruder can be displayed on the monitor for the reference of the farmer. With the usage of the GSM module, the farmer is also notified of the extent of incursion by email, allowing him to take appropriate action. In addition to the mail message and image, the system includes an alarm or buzzer that provides an audible alert. In case the farmer is out of network coverage the near by farmers will be notified with the alarm and with no time for the intruder to destroy crops actions can be taken and also the alarm can scare-away the intruder to some extent. They system output is based on the number of PIR sensors triggered that is, higher the number of PIR sensors triggered, larger is the size of the intruder and the lower the number of PIR sensors triggered, smaller is the size of the intruder and hence, required measures can be taken to keep the animals or intruder from destroying crops in the respective farmland or even the surrounding farmlands.

As a result, a decision is made depending on the number of PIR sensors going high to automate the intrusion detection system as stated above. As a result, the primary operating principle is based on the idea that fewer sensors activating on motion detection signals animals of little or low stature, such as deer, pigs, dogs, cats, and a variety of other animals, and the buzzer warning is

activated. The alarm will result in loud noise and this will ward off the animals or intruders.

As a result, the output is split into two pieces. The first is image transmission from the camera to the monitor, and the second is mail transfer through GSM module to the owner. The mail conveys the message which states the level of intrusion that is low, medium or high. In addition, the buzzer emits an alarm that draws the attention of people in the area of the farm and warns them about the incursion.

The system's block diagram is shown in Fig 1.

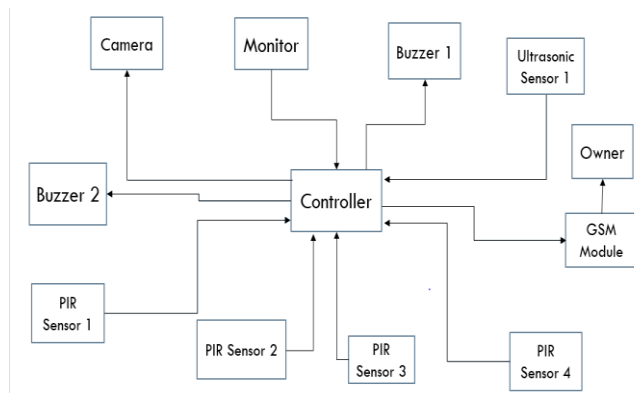

Fig (1)

### 8. METHOD

As previously said, the supplied system will produce an output when PIR sensors are activated, and the threat level will be determined appropriately. First the intruder faces the ultrasonic sensor which in turn makes PIR sensor active thus, the placement of ultrasonic sensor is very important. Because the PIR sensors will be determining the level of hazard offered by the invader, they must be set properly. The system uses four PIR sensors, the placement of which is detailed below. One PIR sensor is installed on the ground, covering a total area of 5 meters. It is located precisely at the field's entrance, with a detection range of 2.5 meters outside and 2.5 meters inside the field.

After one of the four PIR sensors is installed on the ground, the remaining three are stacked vertically above each other with a little gap between them. The intrusion of a specific type of animal is indicated by the combination of PIR sensors turning high.

Placement of the PIR sensors is as follows: 1 On the ground, the first PIR sensor is installed. 2 Second PIR sensor is placed 3 feet above the first one. 3 Third Pir

sensor is placed 2 feet above the second one. 4 Fourth PIR sensor is placed 3 feet above the third one.

When the PIR sensor placed on the ground is triggered and all the other remain low that indicates the entry of a snake in the field. When the bottom most sensor and the sensor just above the ground level sensor both go high this indicates the entry of animals like wild boars or pig. Whereas if all the three sensors from the bottom are high except the top most this indicates the entry of a bear, deer or a human. When all of the PIR sensors are activated, it means an elephant or other huge animal, such as a rhino, has entered. All those animals cause different level of damage in their own way. So, those animals are categorized in three groups that are low, medium and high risk and mail is sent accordingly. If the intruder is supposed to be a wild boar it causes serious damage so mail will read high risk, if the intruder is snake which does not cause much damage to the crops so mail will read low risk and if the intruder is supposed to be a bear, human or deer who can cause much damage so mail will read high risk. If all of the PIR sensors are low, it signifies there is no intruder, the farm is secure, and there is no harm to the crops.

### 9. RESULTS AND OBSERVATION

S. No.	Objects to be sensed	Sensors					Actions Taken		
		Ultrasonic sensor	PIR 1	PIR 2	PIR 3	PIR 4	Mail sent	Alarm	Image
1	Stone	High	Low	Low	Low	Low	No	No	No
2	Rat	High	High	Low	Low	Low	Yes	Yes	Yes
3	Dog	High	High	High	Low	Low	Yes	Yes	Yes
4	Human	High	High	High	High	Low	Yes	Yes	Yes
5	Elephant prop	High	High	High	High	High	Yes	Yes	Yes

Table (1)

Table 1. shows the output of the system when tested against different intruders like living things like rat, dog, human and non-living things like stone and a prop as big as an elephant.

Table 2. shows the possibility of types of intruders that can be present in respective crop fields.

Sr. No.	Different crop fields	Possible intruders
1	Carrot	Rabbit, Rats
2	Groundnuts	Monkey, Cows, Goats
3	Sugarcanes	Elephants, Snakes
4	Botanical	Snakes, Rats
5	Tomato	Cows, Goats, Buffalos

Table (2)

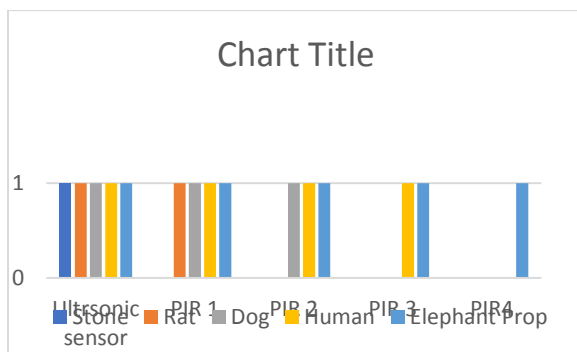

Graph (1)

## 10. DISCUSSION

The system is high on efficiency to a certain extent in detecting the intruder. Also since there is a buzzer installed animals can be fled away with noise that buzzer creates thus keeping them away from the farm. The system is flexible so it's easy to place the system to the required place. It reduces the human supervision, the only supervision needed is to turn the system on and off. All the components used in the system are environment and human friendly. It operates on low power thus eliminating the risk of electric shock and also does not give out any radiations. Since the system transmits data wirelessly through GSM module, the owner can be notified irrespective of his location.

### Advantages: -

- Security surveillance in remote areas.
- Human intervention not required.
- Can be used in several other fields like Banks or other restricted areas.

### Disadvantages: -

- In case of farmlands a little bit skill is required for farmers.
- Motion blur can be seen in the images captured by the camera for fast moving intruders.
- It requires electricity to function.
- It also requires internet connection.

## 11. CONCLUSION

It is our first responsibility to safeguard agricultural resources, as they are the foundation of the Indian economy. We incorporated motion sensors in our system, which effectively detect any intruder motion. This concept of crop protection is simple to apply and can be done so without harming animals or humans. As a result, it's a convenient means of preserving records and focusing on agricultural devastation issues.

## 12. FUTURE SCOPE

In addition to this project, an IoT network may be utilized to connect more surveillance equipment, and a combination of cloud computing might help the system improve significantly. This system can also be used in other areas where human supervision is not possible thus creating a wide range of protected area in the growing population. The breadth of protection can also be extended to include crop protection against birds, which, while not causing much damage, might result in massive losses if left unchecked for a long time.

## REFERENCES

- [1] S. Yadahalli, A. Parmar and A. Deshpande, "Smart Intrusion Detection System for Crop Protection by using Arduino," 2020 Second International Conference on Inventive Research in Computing Applications (ICIRCA), 2020, pp. 405-408, doi: 10.1109/ICIRCA48905.2020.9182868.
- [2] A. V. Deorankar and A. A. Rohankar, "An Analytical Approach for Soil and Land Classification System using Image Processing," 2020 5th International Conference on Communication and Electronics Systems (ICCES), 2020, pp. 1416-1420, doi: 10.1109/ICCES48766.2020.9137952.

- [3] P. S. Dhake and S. S. Borde, "Embedded surveillance system using pir sensor," International Journal of Advanced Technology in Engineering and Science, www. ijates. com Volume, no. 02, 2014.
- [4] R. Vigneshwar and R. Maheswari, "Development of embedded based system to monitor elephant intrusion in forest border areas using internet of things," International Journal of Engineering Research, vol. 5, no. 7, pp. 594–598, 2016.
- [5] R. Nikhil, B. S. Anisha and R. Kumar P., "Real-Time Monitoring of Agricultural Land with Crop Prediction and Animal Intrusion Prevention using Internet of Things and Machine Learning at Edge," 2020 IEEE International Conference on Electronics, Computing and Communication Technologies (CONECCT), 2020, pp. 1-6, doi: 10.1109/CONECCT50063.2020.9198508.
- [6] K. Rao, R. Maikhuri, S. Nautiyal, and K. G. Saxena, "Crop damage and livestock depredation by wildlife: a case study from nanda devi biosphere reserve, india," Journal of Environmental Management, vol. 66, no. 3, pp. 317–327, 2002.
- [7] R. Bhardwaj, K. Bera, O. Jadhav, P. Gaikwad, and T. Gupta, "Intrusion detection through image processing and getting notified via sms and image," 2018.
- [8] A. V. Deshpande, "Design and implementation of an intelligent security system for farm protection from wild animals," International Journal of Science and Research, ISSN (Online), pp. 2319–7064, 2016.
- [9] V. Bavane, A. Raut, S. Sonune, A. Bawane, and P. Jawandhiya, "Protection of crops from wild animals using intelligent surveillance system."
- [10] S. Pandey and S. B. Bajracharya, "Crop protection and its effectiveness against wildlife: A case study of two villages of shivapuri national park, nepal," Nepal Journal of Science and Technology, vol. 16, no. 1, pp. 1– 10, 2015.
- [11] R. R. Ragade, "Embedded home surveillance system with pyroelectric infrared sensor using gsm," in 2017 1st International Conference on Intelligent Systems and Information Management (ICISIM).IEEE, 2017, pp. 321–324.
- [12] B. Jayanthi and D. Prabakaran, "Border security system using sensor interface."