

# Milk Analyser Display using 7-segment LEDs

Pradnya Anil Kamble<sup>1</sup>, Utkarsha Uday Haldankar<sup>2</sup>, Astha Sandip Shaha<sup>3</sup>, Rani Arun Bhendigeri<sup>4</sup>, Eknath Chandar Patil<sup>5</sup>

<sup>1,2,3,4</sup> UG Students, Department of Electronics and Telecommunication Engineering, KIT's College of Engineering, Kolhapur, India

<sup>5</sup> Assistant professor, Electronics and Telecommunication Engineering, KIT's College of Engineering, Kolhapur, India

\*\*\*

**Abstract** The task of taking readings of milk analyser parameters on in-built LCD is quite challenging because of its bright background and small size. It creates difficulties while taking reading from longer distances. And hence leads to inaccuracies. This paper presents how this obstacle of taking readings can be overcome by using common 7 segment displays. The parameters such as water, SNF, temperature, fat is displayed on the 7 segment displays. The system described in the paper consists of RS232 through which parameter data can be given to the 8051 microcontroller and data can be displayed on the common cathode 7 segment LEDs using assembly programming. As common cathode 7 segment LEDs are used data is visible over longer distances and parameter readings can be easily noted. And it can also lead to increase in accuracy while taking the readings.

**Key Words:** milk analyser, LCD, RS232, 8051 microcontroller and common cathode 7 segment LEDs.

## 1. INTRODUCTION

Milk is the most commercially sold commodity both by local vendor's as well as supermarkets. However, in local areas to increase the yield certain adulterants are added which may affect the nutritional quality of milk. Milk adulteration is a social problem. Consumption of adulterated milk causes serious health problems and a great concern to the food industry. So, it is necessary to measure certain parameters of the milk. So certain standard parameters like solid not fat (SNF), water, fat, temperature are analysed by the milk analyser. As per Indian Standard SNF in milk should not be less than 8.5% by mass. SNF in milk is associated with health benefits like bone mineral density. Fat content determination is of great importance because this parameter impacts on the price paid per litre of milk. It is necessary to know its value to classify the milk for the preparation of derivatives. Temperature of milk is measured to ensure the good quality milk. Water measurement in milk is one of the key components of food quality control sector as it influences the shelf life and storage condition of the product. So, these important parameters are displayed on the LCD display of milk analyser. This display is very small in size and hence causes limitations for users while taking the readings from

longer distances. So, this limitation can be overcome by using 7 segment LEDs. This paper presents a system in which common cathode 7 segment LEDs are used because of which data is visible over longer distances (at least up to 15ft). It eradicates the errors/hindrances caused while taking readings on in-built LCD.

## 2. BLOCK DIAGRAM

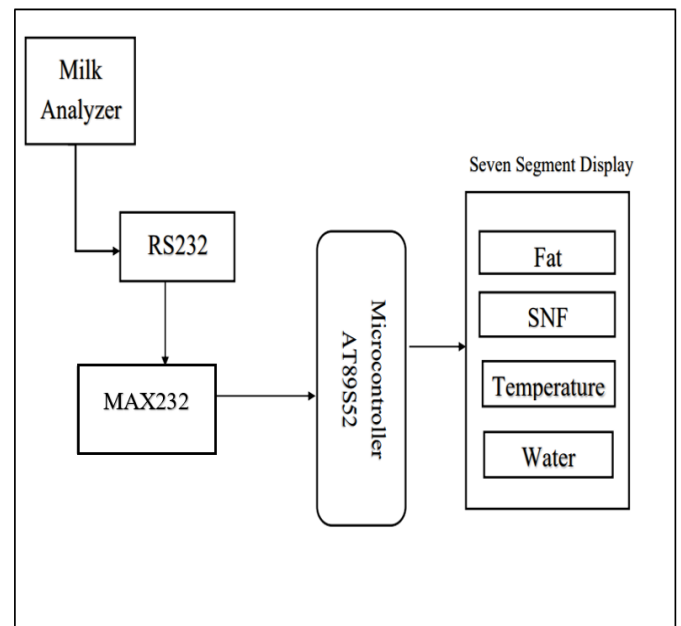

### 2.1 WORKING

The block diagram of Milk Analyser Display is as shown above. A milk sample is given as an input to milk analyzer which sucks-in the milk and analyzes internally and displays different parameters such as fat, SNF, temperature in degree, water etc. on built-in LCD of analyzer. This causes limitation as it is not properly and clearly visible from longer distance, so to solve this problem an external display can be created using seven segments led. The information/ data calculated within the milk analyzer can be given to the microcontroller using RS232 cable. Milk analyzer sends 31-bit character data to the microcontroller. To receive the data, we have to first

enable the serial communication. Then the data is received bit by bit and is stored in the SBUF register. After receiving all the 8-bit data successfully we have to move this data to another memory location so that the next 8-bit data can be received and stored in SBUF register again. All these 31-bit character data is stacked up and stored in the RAM. Microcontrollers and other low-level ICs communicate serially; they usually do so at a TTL (transistor-transistor logic) level. When we connect two serial devices together, it is important to make sure that their signal voltages match up. Otherwise, the Microcontroller would get damaged. Hence, with the use of MAX232 we can match those voltage signals.

Therefore, by using assembly programming on the microcontroller we can display the calculated data on the seven-segment display using persistence of vision concept.

### 3. SYSTEM DESIGN

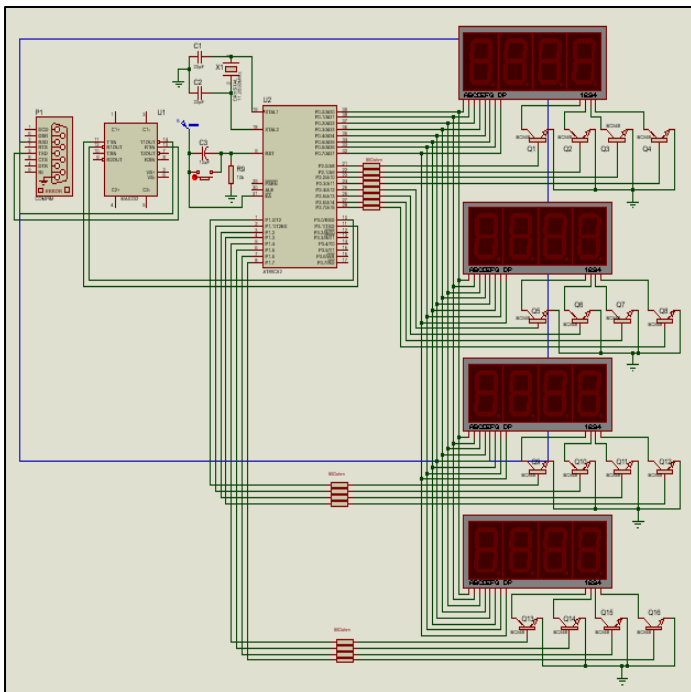

#### 3.1 DESCRIPTION OF CIRCUIT ASSEMBLY

Above figure shows the circuit diagram of Milk analyzer display. Input data received from milk analyzer is given to the microcontroller through RS232 which is serial communication protocol, commonly used for transferring and receiving the serial data between two devices. The RS232 works at different baud rate. In this project we used 9600 bits/sec. here we used pin no 2 and 3 of Rs232 to transmit and receive data respectively. Milk analyzer uses RS232 which operates at  $\pm 3$  to  $\pm 25$  volts, but microcontrollers use TTL logic which works on 0-5V, are not compatible with RS232 voltage level therefore we used max232 which offers intermediate link between the microcontroller and RS232. The transmitter of Max232

converts the TTL input level to RS232 voltage standards and receiver receives the RS232 input and converts them to TTL level voltage. For this we connected pin RXD and TXD of RS232 to pin no 14( $T1_{out}$ ) and 13( $R1_{in}$ ) of max232 respectively.

$T1_{in}$  pin of max232 which receives serial data at TTL logic level is connected to serial transmitter pin TXD of microcontroller and  $R1_{out}$  pin outputs the serially transmitted data at TTL logic level connected to receiver pin RXD of microcontroller.

For displaying data, we used seven segment display, it can display digits 0 to 9 and even display characters like a, b, c, etc. In this project we used common cathode seven segment. Here pins a to decimal points of each seven-segment connected to port 0 of the microcontroller. Transistors BC548 are used to drive the common cathodes. Common pins are connected to collector, emitter of transistor connected to ground and base of the transistors connected to microcontroller as shown in diagram.

### 4. RESULTS

The concepts discussed in this paper were successfully implemented and developed into a working model. Milk analyser sucks milk sample and analyse the parameters like Fat, SNF, Water, Temperature and the final result is displayed on the 7 segment LED display which is in larger in size. Therefore, all the parameters of milk sample are easily visible from longer distances.

### 5. CONCLUSIONS

Milk analyser system using 7 segment LEDs is mainly designed for small dairies for reducing its cost as well as low power usage. This project is implemented using AT89S52 microcontroller. All the circuit components are combined to form compact and flexible system which analyses and finally displays output on 7 segment LEDs. In this way, problems faced in small dairies and by the individuals for measuring various milk parameters and ensuring good quality milk can be achieved by taking readings form longer distances using 7 segment LEDs.

### REFERENCES

- [1] Milkotester Milk analyzing device - Journal
- [2]<https://www.binaryhexconverter.com/ascii-text-to-hex-converter>
- [3]<https://www.codrey.com/embedded-systems/rs232-serial-communication/>
- [4]<https://www.electronicshub.org/interfacing-7-segment-display-8051/>
- [5]<https://www.electronicshub.org/seven-segment-displays/>