

POWER QUALITY IMPROVEMENT IN ELECTRICAL RAILWAY POWER SYSTEM

Asst. Prof. S.Md.Mazhar Ul Haq, Rayees Ahmed, Syed Aakif Faraz, Abdul Abrar

Department of Electrical and Electronics Engineering, ISL Engineering College, Bandlaguda, Hyderabad, India.

Abstract:

The Power Quality Improvement In Electrical Railway Power System provides continuous power factor correction without manual capacitive bank loading. A PFC controller provides power factor correction and peak current limiting for a switch-mode power converter of any topology (buck, boost or buck-boost), While not having to at once experience inductor current. The PFC manipulate method entails the use of a piecewise-polynomial analog pc (AC) to compute energy transistor on-instances according with separate polynomial transfer functions for power-factor control and peak-current-linking using as inputs current representations of line input voltage (VLN), load output voltage (VLD), and long-term current demand (VCD). A conduction cycle is initiated by way of sensing while the price of exchange inside the inductor modern reaches zero using an auxiliary winding on the cutting-edge garage inductor, and terminated after the computed on-time to implement either power-component control or top-modern-day-restricting. The Reactive Power charge on your electricity bill is directly targeted against those companies who do not demonstrate clear energy efficiency use. We will locate this rate itemized on electricity bill. Reactive strength expenses can be made substantially smaller by means of the introduction of Power Factor Correction Capacitors which is a broadly identified method of reducing an electrical load and minimizing wasted energy, improving the efficiency of a plant and reducing the electricity bill. It is not always necessary to reach a power factor of 1. A cost effective solution can be achieved by increasing your power factor to greater than 0.95. This project makes use of regulated 5V, 750mA power deliver. 7805 three terminal voltage regulator is used for voltage regulation and a Bridge type full wave rectifier is used to rectify the ac output of secondary of 230/12V step down transformer.

Aim of The Project :-

This mission offers non-stop energy factor correction with out manual capacitive bank loading. A PFC controller provides power thing correction and height cutting-edge restricting for a transfer-mode power converter of any topology (dollar, increase or greenback-boost), while not having to without delay experience inductor current. The PFC control method involves the use of a piecewise-polynomial analog computer (AC) to compute energy transistor on-times according with separate polynomial transfer capabilities for power-thing manage and peak-present day-linking using as inputs cutting-edge representations of line enter voltage (VLN), load output voltage (VLD), and long-term present day call for (VCD). A conduction cycle is initiated through sensing when the rate of change within the inductor modern-day reaches 0 the usage of an auxiliary winding on the current garage inductor, and terminated after the computed on-time to enforce both power-thing control or peak-cutting-edge-proscribing.

Power factor and its importance

Power factor (pf) is described as the ratio of the actual energy (P) to obvious strength (S), or the cosine (for pure sine wave for each present day and voltage) that represents the section perspective between the current and voltage waveforms. The electricity aspect can vary among zero and 1, and can be both inductive (lagging) or capacitive (main)

Some of the benefits of improving your power factor include:

Eliminating the strength issue penalty

Increased system capacity and reduced system losses in your electrical system

Reducing peak KW billing call for

BLOCK DIAGRAM

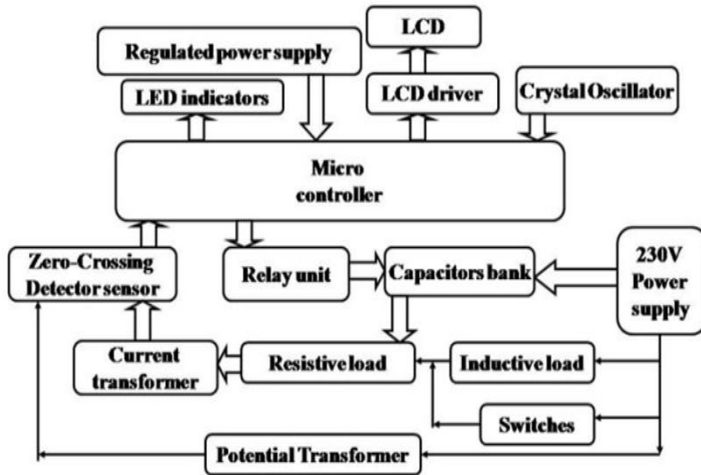

Major components :-

1.Regulated Power Supply

Every embedded device requires dc voltage and that to be able to be 5v deliver We have become 230v, 50 Hz in our family applications. We can be used to function the house appliances like T.V, cooler, fan, light’s Digital electronic gadgets need virtual supply and we are able to get deliver from regulated strength supply block.

2.Transformer

Transformer is a electromagnetic device which induces the voltage because of magnetic subject gift among primary and secondary windings. It has two windings referred to as as primary winding and secondary winding. We are giving input 230v enter voltage at number one side. The output of transformer is 9v(ac best).In this project we're the usage of 9vstep down transformer

3.Rectifier

Rectifier is circuit which converts the ac in to dc. We have two styles of rectifier. In this venture we are using bridge rectifier because the efficiency of the bridge rectifier is high examine to all rectifiers

4.Capacitive Filter

The output of rectifier isn't always pure DC. It can also comprise a few ripple components that is pulsating DC. To remove this ripple additives that are found in output we're using filter. Filter is a circuit which is used to eliminate the ripples present in rectified output.

5.Regulator

The output of filter is not constant output voltage it will. Varies in step with adjustments in input however we want steady output voltage. For this reason we're the use of voltage regulator. Regulator is described as it is a tool which will hold consistent output irrespective of adjustments in enter. The most famous regulator collection is 78xx series. This collection have extra advantages. We are the use of 7805 voltage regulator to hold consistent 5v output voltage regardless of changes in input voltage

6.Microcontroller

A microcontroller is a small pc on a single incorporated circuit consisting of a extraordinarily easy CPU blended with assist capabilities along with a crystal oscillator, timers, watchdog timer, serial and analog I/O etc. Microcontrollers are also used in scientific, excessive technology, and aerospace projects. Microcontrollers are designed for small or devoted programs Some microcontrollers may additionally function at clock fee frequencies as low as four kHz, as this is good enough for plenty normal packages, allowing low energy consumption (mill watts or microwatts)Microcontrollers are utilized in robotically managed merchandise and devices, which include vehicle engine control structures, far flung controls, workplace machines, home equipment, strength gear, and toys. A microcontroller may be taken into consideration a self-contained system with a processor, reminiscence and peripherals and may be used with an embedded machine Microcontrollers ought to provide real time response to occasions in the embedded machine they're controlling. When certain events arise, an interrupt device can signal the processor to suspend processing the current practise series and to begin an interrupt carrier habitual (ISR, or "interrupt handler").Embedded processors are

typically used to govern devices, they once in a while need to accept input from the device they are controlling



7.PIC Microcontroller

PIC is a own family of Harvard structure microcontrollers made by using Microchip Technology, derived from the PIC1640 initially evolved by way of General Instrument's Microelectronics Division. The call PIC initially noted "Peripheral Interface Controller". A PIC's instructions vary from approximately 35 commands for the low-give up PICs to over eighty commands for the high-end PICs. The instruction set consists of instructions to perform a lot of operations on registers at once, the accumulator and a literal consistent or the accumulator and a check in, as well as for conditional execution, and program branching

8.Relay

Relay is an electromagnetic transfer. . It includes a coil of cord surrounding a gentle iron middle, an iron yoke, which gives a low reluctance course for magnetic flux, a movable iron armature, and a set, or sets, of contacts; inside the relay pictured. The armature is hinged to the yoke and routinely linked to a moving contact or contacts. When an electric powered modern-day is passed thru the coil, the resulting magnetic subject attracts the armature and the resultant motion of the movable contact or contacts both makes or breaks a reference to a set touch

9.LCD Display

A liquid crystal show (LCD) is a thin, flat digital visual show that makes use of the light modulating residences of liquid crystals.Liquid crystal display may be very critical device in embedded device. It offers high flexibility to consumer as he can display the specified

facts on it. These are utilized in a wide variety of applications, which includes pc video display units, tv, device panels, plane, cockpit displays, signage, etc

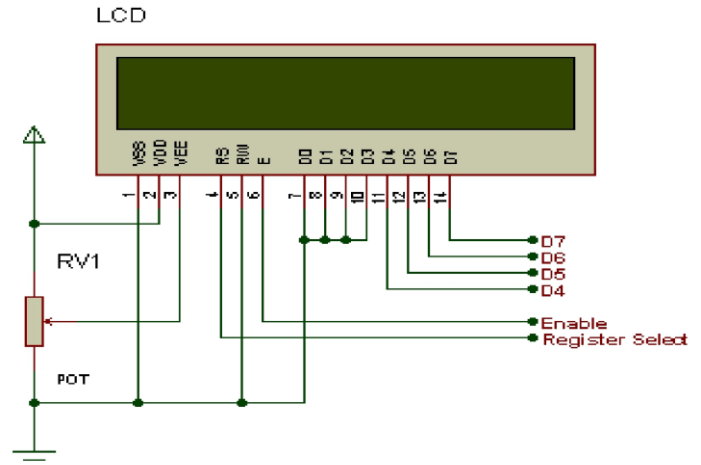

PIN DESCRIPTION

Pin No.	Name	Description
Pin no. 1	VSS	Power supply (GND)
Pin no. 2	VCC	Power supply (+5V)
Pin no. 3	VEE	Contrast adjust
Pin no. 4	RS	0 = Instruction input 1 = Data input
Pin no. 5	R/W	0 = Write to LCD module 1 = Read from LCD module
Pin no. 6	EN	Enable signal
Pin no. 7	D0	Data bus line 0 (LSB)
Pin no. 8	D1	Data bus line 1
Pin no. 9	D2	Data bus line 2
Pin no. 10	D3	Data bus line 3
Pin no. 11	D4	Data bus line 4
Pin no. 12	D5	Data bus line 5
Pin no. 13	D6	Data bus line 6
Pin no. 14	D7	Data bus line 7 (MSB)

10.Zero Crossing Detector

Zero crossing detection is the manner of locating the variant of waveform from 0 as reference point. In this mission that is used to discover whether or not each contemporary and voltage wave paperwork are main or lagging or in segment with each other.

11.Reset Button

Reset is used for placing the microcontroller into a 'regarded' circumstance. That nearly way that microcontroller can behave as an alternative inaccurately beneath sure undesirable situations. In order to maintain its proper functioning it must be reset. A switch placed among the virtual input and floor will short the digital enter to floor whilst it is pressed. This means the voltage seen at the input may be excessive when the switch is open and coffee while the switch is closed



12.Oscillator

An digital oscillator is an electronic circuit that produces a repetitive Electronic sign, frequently a sine wave or a rectangular wave.PIC micro controller internally having 4mhz clock frequency. We are giving the 20Mhz clock frequency as an outside source for growing the device performance.



13.LED Indicators

LED (Light Emitting Diode) is a semiconductor mild source used as an indicator. In the challenge, LED signs are used to show the Microcontroller health Status and indications for numerous operations LED s used in the undertaking works with 2V, 10Ma

WORKING :

The schematic diagram explains the interfacing segment of every component with micro controller, LCD and relay module. The crystal oscillator connected to thirteenth and 14th pins of micro controller and controlled strength supply is also related to micro controller and LED's additionally linked to micro controller via resistors and motor motive force related to micro controller. This circuit consists of DC electricity supply unit, zero voltage crossing detectors, Micro-controller, LCD display, Relays and Capacitor financial institution and Load circuit. Let us see the way it operates. The required DC energy deliver for Micro- controller and different peripherals is furnished by the DC energy supply For the calculation of the power element by the Micro-controller we need digitized voltage and current indicators. The voltage signal from the mains is taken and it's miles converted into pulsating DC by using bridge rectifier and is given to comparator which generates the digital voltage signal. Similarly the contemporary signal is converted into the voltage sign via taking the voltage drop of the load modern-day across a resistor of 10 ohms. This A.C signal is once more converted into the virtual sign as completed for the voltage signal. Then these digitized voltage and modern-day signals are despatched to the micro-controller. The micro- controller calculates the time distinction among the 0 crossing points of present day and voltage, which is without delay proportional to the strength aspect and it determines the range wherein the strength issue is. Micro - controller sends statistics regarding time distinction between contemporary and voltage and strength element to the LCD show to display them, Depending on the range it sends the signals to the relays thru the relay driving force. Then the desired wide variety of capacitors is connected in parallel to the weight. By this the power aspect could be improved

Advantages

The kW capacity of the prime movers is better utilized.

This increases the kilowatt capacity of the alternators.

The kW capacity of transmission and the lines are accelerated.

The efficiency of every plant is increased.

The ordinary price in keeping with unit reduced.

The regulation of the lines is stepped forward.

Fast response.

Efficient and low cost design.

Low power intake.

Applications

1.Can be used to all loads to improve the power factor.

2.Can be used for industrial loads

CONCLUSION

Integrating capabilities of all the hardware additives used had been developed in it. Presence of every module has been reasoned out and located carefully, for that reason contributing to the first-class operating of the unit. Secondly, the usage of especially advanced IC's with the help of developing era, the undertaking has been effectively applied. Thus the mission has been efficaciously designed and tested. So, through the usage of the Automatic Power Factor Improvement module we can efficaciously enhance the power factor for variable inductive hundreds, enhancing the existence span of device and lowering electricity payments.

REFERENCES

1.G. Raimondo,P.Ladoux,A.Lowinsky, H. Caron, and P. Marino, "Reactive power compensation in railways based on AC boost choppers," *IET Electr. Syst. Transp.*, vol. 2, no. 4, pp. 169–177, Jua. 2012.

2. S. Gazafrudi, A. Langerudy, E. Fuchs, and K. Al-Haddad, "Power quality issues in railway electrification: a comprehensive perspective," *IEEE Trans. Ind. Electron.*, vol. 62, no. 5, pp. 3081–3090, May. 2015