

Detection and Classification of ECG Arrhythmia using LSTM Autoencoder

Vivek Mishra^{1*}, Arjit Bhandari^{2*}, Gajendra Farswan^{3*}, Harshit Srivastava^{4*} and Himani Prajapati^{5*}

** Department of Computer Science and Engineering, Delhi Technical Campus, Greater Noida, U. P., India*

Abstract - An arrhythmia is an issue with the rate or beat of your pulse. It implies that heart beats either excessively fast, too leisurely, or with a sporadic example.

An electrocardiogram keeps the electrical signs in the heart. It's a typical and easy test used to identify heart issues and screen the heart's wellbeing rapidly. Because of the extremely low amplitudes, outwardly evaluating the ECG cautions might be hard and tedious. Carrying out a programmed technique inside side the clinical setting should presumably speed up and enhance the exactness of arrhythmia conclusion. In this paper, we advocate a programmed machine for distinguishing conventional sinus cadence, R-on-T Premature Ventricular Contraction (R-on-T PVC), Supra-ventricular Premature or Ectopic Beat (SP or EB), Unclassified Beat (UB) and unfavorable ventricular compression (PVC) on ECG cautions the use of an extended brief time frame period memory (LSTM). The essential driver of this glance at is to make a profound dominating strategy for arranging exceptional types of arrhythmia this is straightforward, reliable, and clean to utilize. To classify normal and obsessive beats in an ECG, intermittent brain organizations (RNN) have been utilized. The significant expectation of this reviews changed into to make it doable to regularly recognize among consistently and strange beats. The beat type in general execution is surveyed the use of the MIT-BIH Arrhythmia information base. As contributions to the Long Short Term Memory Network, a major amount of famous information, comprising of ECG time-assortment information, is utilized. The dataset changed into isolated into schooling and evaluating sub-information. The proposed strategy done pleasantly in expressions of type, with a 97 rate precision rate. Our proposed strategy can help clinicians in as it ought to distinguish actually normal spot arrhythmias.

Keywords: Deep Learning, Recurrent Neural Networks, ECG Detection and Classification, Long Short Term Memory

1. INTRODUCTION

An electrocardiogram (ECG) is one of the easiest and quickest tests used to assess the heart. Cathodes (little, plastic fixes that adhere to the skin) are put at specific spots on the chest, arms, and legs. The terminals are associated with an ECG machine by lead wires. The electrical action of the heart is then estimated, deciphered, and printed out. No power is sent into the body.

Ordinary electrical inspirations coordinate compressions of the different bits of the heart to keep the blood spilling in how it should. An ECG records these inspirations to show how speedy the heart is pounding, the rhythm of the pulses (reliable or flighty), and the strength and timing of the electrical main thrusts as they travel through the different bits of the heart. Changes in an ECG can be a sign of various heart-related conditions.

Early examination of coronary heart issues (anomalies) at an early age can serve to development presence and decorate excellent of presence. Changes or abnormalities inside side the ECG signal noticed through a human spectator had been a customary procedure of distinguishing cardiovascular problems. Subsequently, it's miles basic to decorate the precision and viability of sign mechanization and beat class.

Programmed heart arrhythmia class will give goal indicative impacts and keep up with time for cardiologists. These benefits have started a whirlwind of office interest inside side the classification and investigation of ECG realities utilizing PC power.

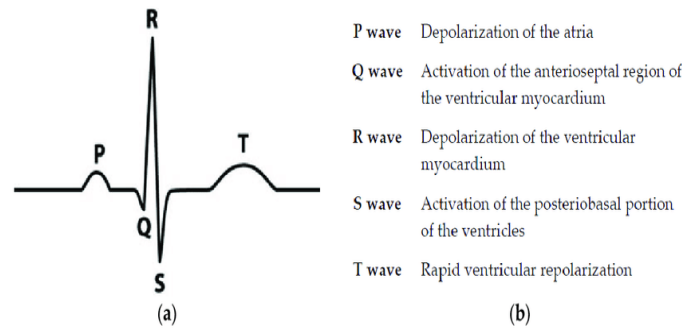

Figure 1: ECG Signal Curve (Source: Research Gate)

Conventional AI calculations just utilize info and result layers, and probably a solitary secret layer. Utilization of multiple layers (counting info and result) is alluded to as "profound" learning [17]. Figure 2 recognizes basic NN and profound learning NN. The fundamental advantage of DNN (Deep Neural Network) is that it can perceive more intricate elements in light of the number of secret layers it contains. This capacity of DNN makes it able to deal with huge, high-layered information which contains an enormous number of highlights. Profound learning networks end in a result layer: a calculated, or softmax, classifier that relegates a probability to a specific result or name [17]. In the proposed calculations, two Physio Bank datasets (typical sinus mood data set (NSR-DB) and MIT/BIH arrhythmia data set) were utilized to recognize ordinary and unusual ECG signals, for which the multi-facet perceptron method was utilized. Another calculation utilizes a four-layer of convolution brain organization (CNN) to identify different arrhythmias in erratic length ECG dataset highlights. The dataset that was utilized in this study contains different heart illnesses, for example, arrhythmia, typical sinus, second degree AV block, first degree AV block, atrial shudder, atrial fibrillation, harmful ventricular, and ventricular tachycardia, and ventricular bigeminy. It was downloaded from kaggle.com. The models were prepared with the assistance Tensor Flow library created by Google in 2015 explicitly for AI and profound brain organizations. When the two models had been prepared on the downloaded ECG dataset, they were prepared with another dataset with various attributes from the preparation dataset.

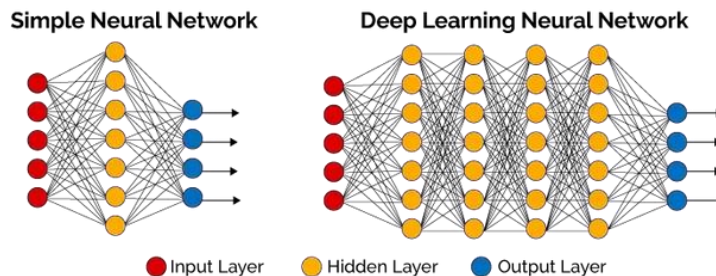

Figure 2: Comparison between simple neural network (NN) and deep NN; simple neural networks contain only one hidden layer as well as the input and output layers, while deep learning neural networks contain more than one hidden layer. In this case, there are four hidden layers between the input and output layers

Cardiologists, who've gone through years contemplating segregating among consistently and arrhythmic beats, have bombed a few occasions on account of human instinct, thinking about also exploration and development of this discipline of biotechnology. For distinguishing arrhythmia, various frameworks considering and profound concentrating on designs had been utilized, and various them have beaten cardiologists. We will currently find different framework reading up designs for arrhythmia discovery with a reason to accomplish a higher skill of the styles and to advantage experiences into what should and may be appropriate for this discipline of studies.

To dispose of the need for human discovery of arrhythmic thumps withinside the ECG, we utilized a framework concentrating on the device to hit upon unusual pulsates consequently, which can likewise moreover then be taken to a heart expert for check and additional examination. The sort precision might appear to a couple of levels, and this paper can help docs work on their artworks and be thought about for predetermination advancement and improvement.

2. RELATED WORKS

Thus, this pamphlet utilizes repetitive brain networks with outstanding boundaries and an assortment of ages, in which the precision changes in light of the fact that the neurons withinside the secret layer and the assortment of ages.

To deliver robotized notoriety and revelation of ECG, superb methods were accessible. To improve execution, Support Vector Machines (SVM), Multilayer Perceptron (MLP), Markov Models, Fuzzy or Neuro-fluffy Systems, and various strategies were proposed. So far, just a few investigators have attempted to analyze coronary heartbeats with the utilization of SVM and an outstanding classifier. Throughout the long term, different techniques for developing mechanized frameworks to precisely coordinate ECG realities were proposed. These techniques include wavelet changes, direct vector quantization, probabilistic brain organizations, and fluffy hybrid brain frameworks. Silipo et al. proposed an ECG portrayal separation undertaking that pre-owned open door affiliation strategies: one with a directed getting to know the approach and the option with unlabeled realities. Sugiura and collaborators made fluffy reasoning basically based thoroughly machine for distinguishing ECG and ventricular arrhythmias. Acharya et al. employed coronary heart expense variability (HRV) in light of the fact that the basic banner and ANN and fluffy proportionality associations with arranging 4 ECG arrhythmias. SVM-fundamentally based absolutely arrhythmia relationship, in accordance with Kohli et al., is connected with 3 methods: one instead of one, one contrary to all, and fluffy determination limit. In this work of art, a one-contra-ry to-all approach outflanks various procedures in expressions of accuracy. Jadhav et al. made 3 remarkable ANN styles for identifying coronary heart arrhythmia. An RNN variant is advanced in this paper to sort arrhythmia in pulses.

Most of the present-day research on this discipline have focused on distinguishing different cardiovascular sicknesses. ECG cautions, for instance, was solidly used to order arrhythmias, find myocardial ischemia, and analyze coronary corridor sickness. The ee-digital book presents a total assessment of the advanced realm of ECG sign handling and understanding.

The ECG cautions manage structure for various non-heart conditions, along with aspiratory embolism, significant restless machine (CNS) afflictions, myasthenia gravis, muscle quakes, hypothermia, and hypothyroidism, in accordance with [15]. One more glance at [16] found that changes are gift for different esophageal difficulties correspondingly to CNS afflictions. Medications, poisons, and electric damage have furthermore been affirmed to have a major impact on the waveform of ECG alarms. Creators of each and every other examination [17] offered a gander that affirmed a hyperlink among Friedreich's ataxia and electrocardiographic realities. These aides had been fundamental for information on the coronary heart's realities work, but because of the reality they depend upon a specific kind of ECG irregularity, the proposed processes couldn't be stretched out to choose additional issues. Uspensky by and large addressed the issue in [1-2]. In his exploration, he advanced a fixed of 216 capacities that had been recovered from electrocardiograms and used to order diseases. The proposed strategy changed into put to the investigate a fixed of 30 diseases and was accomplished honorably. This procedure, nonetheless, isn't without imperfections. First of all, it doesn't adapt to if the conscious abilities will artwork appropriately on new illnesses. Another trouble is that abilities had been made through the method of method for hand, thusly a couple of realities from the stock realities can be lost.

3. METHODOLOGY USED

We used Recurrent Neural Networks to continue with the categorization and analysis of arrhythmic beats on this paper. The percent of accuracy is used to degree the effectiveness of RNN-primarily based totally heartbeat categorization. A cautious evaluation of the paintings that has already been accomplished withinside the challenge is likewise carried out, with the maximum crucial elements taken into account. When the need to paintings with sequential records arose, including handwriting identity and speech recognition, a critical kind of synthetic neural networks arose. Recurrent Neural Networks are a kind of synthetic neural community which can method and classify arbitrary sequences of inputs the use of their inner memory, and the connections among the gadgets shape a directed cycle.

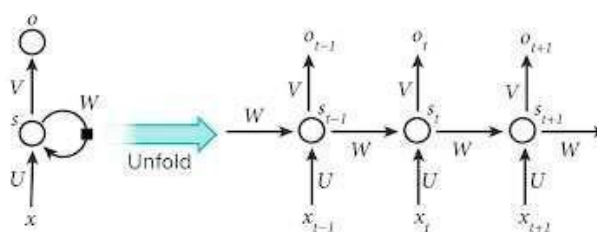

Figure 3: Recurrent Neural Network (Source: ICCIDS)

Deep learning knowledge is a completely interesting topic, and it's been hired via way of means of some of lecturers to enhance and enhance overall performance and accuracy measures. RNN and CNN are of the maximum charming domain names of Deep Learning, and they've each been used to categorize ECG arrhythmias. However, while CNN is used to categorize ECG, it breaks the beats into fixed-period parts, which reduces category overall performance. The overall performance of RNN may be progressed via way of means of giving custom functions to the classifier, making it higher in a few ways. We use RNN to analyze the underlying key residences of the beats nicely and robotically via way of means of feeding the contemporary beat and the ultimate beat, i.e. T beat.

3.1 Recurrent Neural Network

Because in their extraordinarily dynamic activity, recurrent neural networks emerged, while multilayer feed-ahead networks have static mappings. RNNs had been hired in quite a few fields and feature packages in associative memories, optimization, and generalization. RNNs are first-rate for classifying time-collection statistics due to the fact the comments and present day cost are fed again into the network, and the output consists of strains of values saved withinside the reminiscence, which improves class overall performance and gives higher outcomes than general feed-ahead networks.

3.2 Long Short Term Memory Network

The Long Short-Term Memory (LSTM) structure is a shape of recurrent neural network (RNN). LSTMs have been created to version temporal sequences, and RNNs' long-variety dependencies and reminiscence backup play a vital role, making them extra correct and powerful than conventional RNNs. The method is used after the statistics has been pre-processed to put off any undesirable, missing, or null sign values.

Three layers of RNN-LSTM had been utilised on this research, with 64, 256, and one hundred neurons in every layer, respectively, and 5 iterations. After every layer, a 0.2 fee dropout has been introduced. The loss feature became MSE, at the same time as the activation became sigmoid.

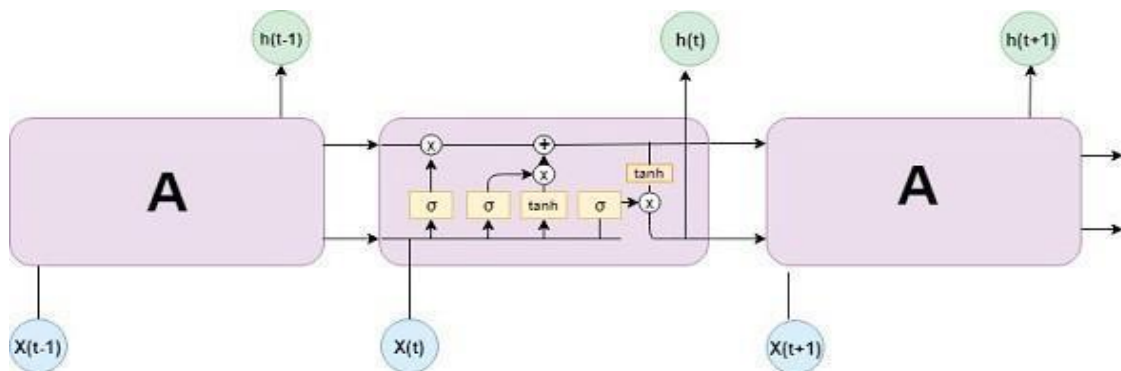

Figure 4: Long Short Term Memory (Source: ICCIDS)

3.3 Autoencoder

The Autoencoder's assignment is to obtain a few enter facts, run it via the version, and recreate the enter. The reconstruction ought to be as near the authentic as possible. The key's to restrict the quantity of parameters to your version in order that it is able to examine a compressed illustration of the facts.

Autoencoders, in a sense, attempt to examine most effective the maximum tremendous factors of the facts (compressed version). We'll study the way to feed Time Series facts to an Autoencoder on this section. To seize the temporal dependencies of the facts, we're going to utilize more than one LSTM layers (hence the LSTM Autoencoder). We'll pick a threshold above which a heartbeat is appeared strange to discover a series as regular or strange. The intention of Autoencoder schooling is to reconstruct the enter as it should be as feasible. This is carried out via the usage of a loss characteristic this is minimized (much like in supervised learning). Reconstruction loss is the call given to this characteristic. Examples encompass cross-entropy loss and suggest squared error.

There are components to the Autoencoder structure in general. The enter is compressed through an encoder, and the output is decoded through a decoder. To compress the Time Series facts enter, the Encoder employs LSTM layers.

Two LSTM layers and an output layer offer the very last reconstruction in our Decoder.

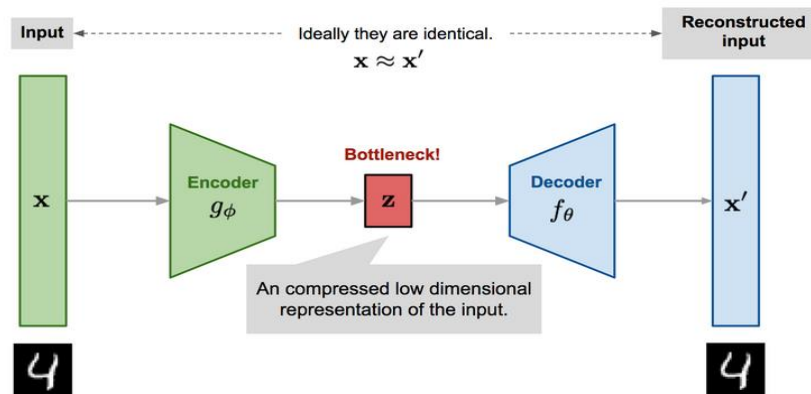

Figure 5: Autoencoder (Source: Curiosity.com)

3.4 Dataset

This dataset is a bunch of heartbeat markers got from the MIT-BIH Arrhythmia Dataset, a popular dataset for heartbeat order. The amount of data withinside the series is to the point of instructing a profound brain local area.

This dataset has been utilized to break down heartbeat arrangement the utilization of profound brain local area designs, notwithstanding to check sure switch getting to know abilities. For the customary case and occasions bothered with the guide of utilizing different arrhythmias and myocardial dead tissue, the markers compare to electrocardiogram (ECG) sorts of pulses. These pointers are fragmented and preprocessed, with each stage addressing a heartbeat.

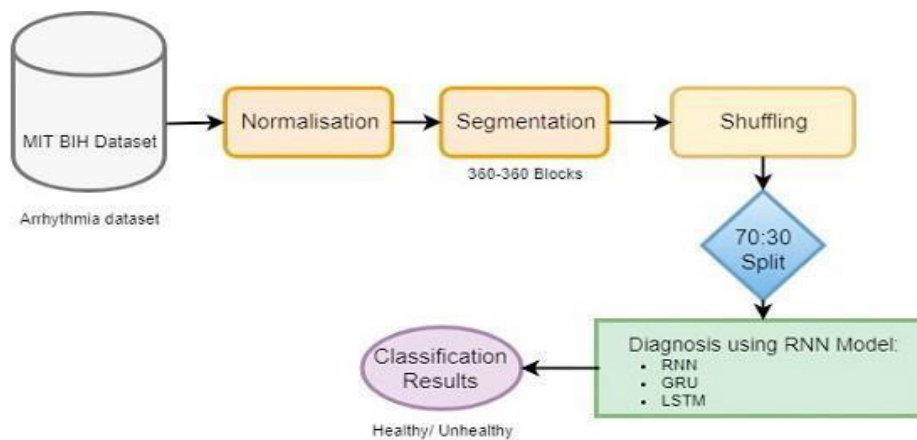

Figure 6: Flow Diagram (Source: ICCIDS)

4. CONCLUSION AND FUTURE WORK

In this research, we fostered a determination framework for distinguishing different cardiovascular illnesses utilizing profound learning techniques. By and large, ECG arrhythmias can be effortlessly recognized from its shape. Because of the pervasiveness of genuine arrhythmias, there is a need to foster an efficient and powerful CAD (PC supported plan) framework to precisely and naturally distinguish a few sorts of arrhythmias. The proposed calculations were tried on ECG signals acquired from Physio.net and keggar.com. These establish genuine ECG signals gathered from patients for clinical exploration. The calculations prevailed with regards to identifying all infection states in each sign with huge exactness by utilizing MLP and CNN models (Table A1). The MLP acalculation utilizes four secret layers and the CNN utilizes four convolution layers. In CNN calculation, two illnesses, first-degree AV block (FAV) and ventricular bigeminy, have huge misprediction. These infections could have some similitude in their highlights with different illnesses, prompting disarray of the organization. The expressed outcomes demonstrate the way that the proposed calculations can make productive findings of different cardiovascular illnesses with 88.7% precision for MLP and 83.5% for CNN. Albeit the exhibition of the

expected strategies is nice, the issue of arrhythmia determination is a long way from being tackled. There are numerous complexities worth examining. As per our examination, bigeminy highlights are handily confused with typical, FAV, VT, AF, and AFIB signals, which would prompt misleading up-sides. Profound learning is the most encouraging heading for cardiovascular irregularity identification and more examinations are as yet required that way.

REFERENCES

- [1] V.M. Uspenskiy. Information function of the heart. a measurement model. MEASUREMENT 2011, 1:383-386, 2011.
- [2] V.M. Uspenskiy. Diagnostic system based on the information analysis of electrocardiograph. In Embedded Computing (MECO), 2012 Mediterranean Conference on, pages 74-76, June 2012.
- [3] Wagner Galen and Strauss David. Marriotts Practical Electrocardiography. LWW, 2013.
- [4] K. Perloff Joseph and J. Marelli Ariane. Clinical Recognition of Congenital Heart Disease. Elsevier, 2012.
- [5] Babak Mohammadzadeh Asl, Seyed Kamaledin Setarehdan, and Maryam Mohebbi. Support vector machine-based arrhythmia classification using reduced features of heart rate variability signal. Artificial Intelligence in Medicine, 44(1):51- 64, 2008.
- [6] Mi Hye Song, Jeon Lee, Sung Pil Cho, Kyoung Joung Lee, and Sun Kook Yoo. Support vector machine based arrhythmia classification using reduced features. International Journal of Control, Automation, and Systems, 3:571-579, 2005.
- [7] A.J. Joshi, S. Chandran, V.K. Jayaraman, and B.D. Kulkarni. Hybrid svm for multiclass arrhythmia classification. In Bioinformatics and Biomedicine, 2009. BIBM 09. IEEE International Conference on, pages 287-290, Nov 2009.
- [8] V.Ahanathapillai and J.J. Soraghan. Myocardial ischemia detection algorithm(mida): Automated echocardiography sequence analysis for diagnosis of heart muscle damage. In Computing in Cardiology, 2010, pages 405-408, Sept 2010.
- [9] T. Konttila, M. Stenroos, H. Vaananen, H. Hanninen, M. Lindholm, I. Tierala, and T. Katila. Support vector classification of acute myocardial ischemia with reduced sets of body surface potential map electrodes. In Computers in Cardiology, 2005, pages 869-872, Sept 2005.
- [10] P Ranjith, P.C Baby, and P Joseph. ECG analysis using wavelet transform: application to myocardial ischemia detection. ITBM-RBM, 24(1):44 - 47, 2003.
- [11] Ismail Babaoglu, Mustafa Servet Kiran, Erkan Ulker, and Mesut Gunduz. Diagnosis of coronary artery disease using artificial bee colony and k-nearest neighbor algorithms. International Journal of Computer and Communication Engineering, 2:56-59, 2013.
- [12] R. Alizadehsani, M.J. Hosseini, Z.A. Sani, A. Ghandeharioun, and R. Boghrati. Diagnosis of coronary artery disease using cost-sensitive algorithms. In Data Mining Workshops (ICDMW), 2012 IEEE 12th International Conference on, pages 9-16, Dec 2012.
- [13] A. Kampouraki, G. Manis, and C. Nikou. Heartbeat time series classification with support vector machines. Information Technology in Biomedicine, IEEE Transactions on, 13(4):512-518, July 2009.
- [14] Adam Gacek and Witold Pedrycz. ECG Signal Processing, Classification and Interpretation. Springer-Verlag London, 2012.
- [15] L. Yash, L. Pallavi, and A. Sameer. Ecg in non cardiac disorders.