

A Novel Over Voltage and Under Voltage Protecting System for Industrial and Domestic Applications

Dr. Shimpy Ralhan , Mr Mayank Lahare, Sakshi Singh, Rohan Dewangan

Assistance professor, Department of electrical and electronics engineering, SSTC, Bhilai (C.G.) INDIA

Under graduate student, Department of electrical and electronics engineering, SSTC, Bhilai, (C.G.) INDIA

Abstract: This document introduces a new system to protect industrial and residential loads from AC mains overvoltages and undervoltages. Rapid changes in voltage are a major problem for enterprises and household machinery and bring misery to electrical circuits. On-time circuit cells delay the alternating flooding of the heap and switching (switching on and off) too quickly. This is an inexpensive automatic power-off circuit made using transistors and other discrete components.

Keywords: undervoltage, overvoltage, industrial application, home application, protection system.

1. INTRODUCTION

Unexpected voltage changes are a huge problem in businesses and in homes, and they cause problems in electrical circuits. The On-time put off circuit cells the heap from flood replacement as well as the impact of fast changeover (on and off). This is a synthetic car cut-off circuit that uses transistors and other discrete parts to save money.

Therefore, problems caused by sagging, overvoltage, and undervoltage need to be eliminated and are probably detected and protected with the help of this system.

In this paper, we have established a circuit that can trip to a voltage of less than 198 volts, which is 0.9, which is nominally 220 volts. The sag is miles, and under voltage conditions, the circuit continues open to prevent current flow.

In this case, the down relay of the circuit remains open. If the voltage rises above the rated voltage of 1.1, 242 volts, and it is in a threshold and overvoltage condition, the circuit's top relay remains open during this time, leaving the circuit open. Therefore, you can protect expensive equipment by supplying power through this circuit.

The main goal of this study is to create indicators for low and high voltages. The proposed device protects expensive electrical and electronic equipment from the opposite effects of overvoltage and undervoltage protection. The circuitry of this system has an auto-reset feature and uses easily accessible components. Within the 555 timer, use the available comparators. The main parts of this study are: 555 timer. There are various protection techniques to protect electrical and electronic devices from various unexpected voltages such as overvoltage, undervoltage, common mode voltage, and voltage based on electromagnetic interference.

This paper introduces the basics of overvoltage and undervoltage, the causes of overvoltage and undervoltage, and the effects of overvoltage and undervoltage on power systems. This white paper also details the proposed protection system.

2. UNDERVOLTAGE

Low voltage is defined as a sudden drop in RMS voltage (RMS value) and is usually characterized by the remaining (held) voltage. Therefore, low voltage is a short-term drop in effective value. Voltages caused primarily by short circuits, large motor starts, and equipment failures. In addition, undervoltages can be categorized according to their duration, as shown in the graph.

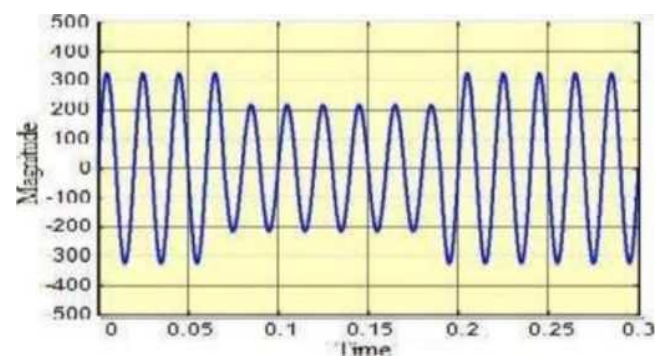

Fig 1: Under voltage

Classification of under voltage according to IEEE :

Types of under voltage	Duration	Magnitude
Instantaneous	0.5 - 30 cycles	0.1 -0.9 pu
Momentary	30 - 3 sec	0.1 -0.9 pu
Temporary	3 sec - 1 min	0.1 -0.9 pu

Low voltage is the most common power failure and its consequences are very serious, especially for industries and large commercial customers such as: B. Damage to sensitive equipment, and daily production and financial losses. Examples of sensitive devices are programmable logic controllers (PLCs), variable speed drives (ASDs), and chiller controls. The low voltage of the device connector can be caused by a short circuit failure in the transmission system hundreds of kilometers away.

3. OVERVOLTAGE

Overvoltage is defined as an increase in RMS value. As shown in Figure 2, voltage values from 1.1 pu to 1.8 pu at the main frequency over a period ranging from half a cycle to 1 minute

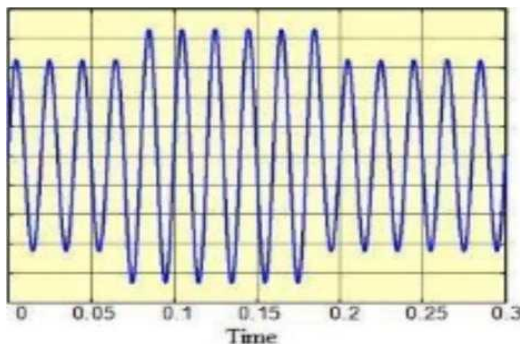

Fig 2: Overvoltage

Overvoltages are rarer than undervoltages, but they can also be caused by system errors. Overvoltages can occur due to single-phase ground fault failures, which increase the voltage in the other phases. This can also be caused by turning off heavy industrial loads or turning on capacitor banks. This is generally due to a non-grounded or floating grounded delta system where changes in reference ground cause a voltage rise in the non-grounded system.

Classification of overvoltage according to IEEE :

Types Of Voltages	Duration	Magnitude
Instantaneous	0.5 - 30 cycles	1.1 - 1.8 pu
Momentary	30 cycles - 3 sec	1.1 - 1.4 pu
Temporary	3 sec - 1 min	1.1 - 1.2 pu

The cause of overvoltage is mainly due to the excitation of the capacitor bank. It can also be caused by sudden load removal. When the load is cut off, the current drops sharply and the voltage rises. Where L is the inductance of the line. The effects of overvoltage are more serious and destructive. This can lead to electrical equipment failure due to high voltage overheating. Electronic devices and other sensitive devices are also prone to malfunction.

4. PROPOSED PROTECTION SYSTEM

The protection system to protect the load from overvoltage and undervoltage consists of various electrical and electronic components and devices such as step-down transformers, rectifiers, filters, voltage regulators LM358 ICs, resistors, capacitors, LEDs and diodes increase. The input of the transformer is connected to the main power supply, that is, 230VAC.

The input can also be given to the variable AC power supply, Variac. The output of the transformer is 12VAC and is supplied to the input of the 12VAC connector on the board..

The operating principle of the circuit lies in the operation of the operational amplifier IC. There is a voltage divider network along with a Zener diode used to control the triggering of power to the AC load connected to the system.

The operating range of the voltage is set in the system with the help of the voltage divider network. This set voltage range applies to the operating range of 180 VAC to 240 VAC at the input of a 12 VAC step-down transformer.

The mapping of the various components is shown in Figures 3-10:



Fig 3: Step Down Transformer



Fig 7: Rectifier

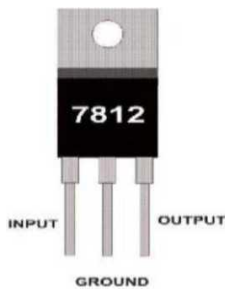

Fig 4: IC 7812



Fig 8: Relay

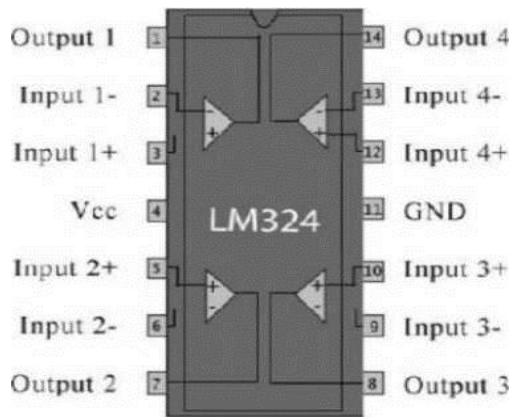

Fig 5: Pin Configuration of LM324

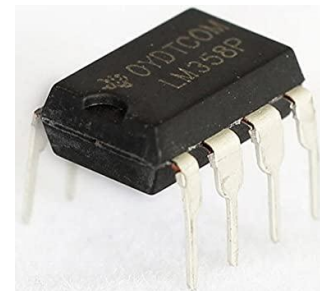

Fig 9: LM358 IC



Fig 6: Transistor

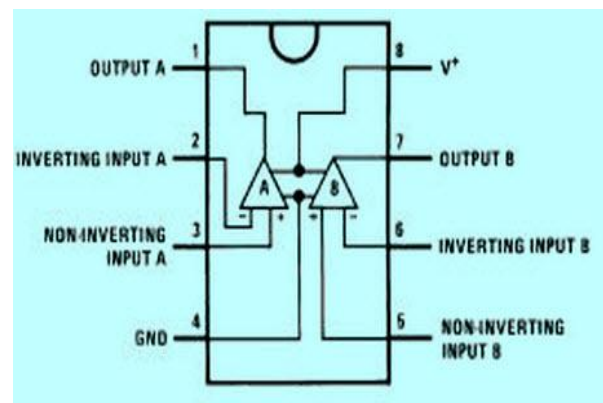

Fig 10: Pin Diagram of LM358 IC

Figure 2 shows the operation of the proposed protection system without overvoltage and undervoltage. 11.11.

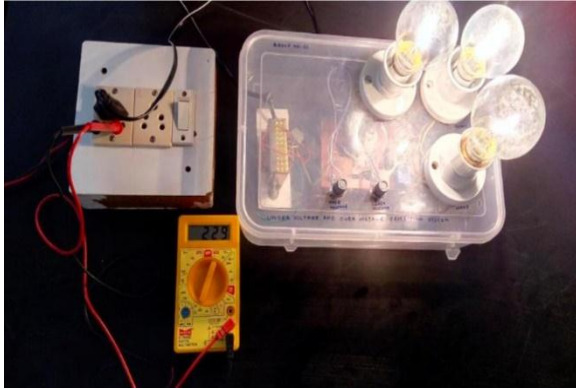

Fig. 11. Proposed system when there is no over voltage and under voltage in AC supply main

Figure 12 shows the behavior of the proposed protection system in the event of an overvoltage on the AC network. Here, the proposed system trips the circuit and protects the lamp load.



Fig.12. Proposed System when there is an over voltage in AC supply mains.

5. CONCLUSION

This document proposes a new system for protecting industrial and residential loads from AC power overvoltages and undervoltages. The proposed system has been designed, manufactured, and tested under two conditions. The first requirement is a standard AC supply with no overvoltage or undervoltage.

The overvoltage in the AC supply is the second condition. With the lamp load, the proposed system performed admirably. As a result, the suggested system is concluded to safeguard industrial and home applications from supply overvoltage and supply undervoltage. The suggested system can be modified to provide three-phase AC power to three-phase loads. The protection circuit can be used to protect expensive electrical appliances from abnormal situations such as sag, swell, undervoltage, and overvoltage, preventing damaging effects.

REFERENCES

1. Manish Paul, Antara Chaudhury. Snigdha Saikia (2015). "Hardware Implementation of Overvoltage and Under voltage Protection", UIREEICE Vol. 3, Issue 6, June 2015, ISSN(Online) 2321-2004.
2. Silicon institute of technology. "Power quality problem. identification and protection scheme for low voltage system". Orissa, November 2010.
3. G.Yalcinkaya, MILJ.Bollen and PACrossley (1999). "Characterization of voltage sags in industrial distribution systems, IEEE transactions on industry applications, vol 34, no 4.pp-682-688, July August.
4. CH Vithalani, Over-Under Voltage Protection of Electrical Appliances August 2003 Electronics for You
5. EPRI Project Manager R.Schinker. System Compatibility Research Project, "Effects of Temporary Overvoltage on Residential Products, 1008540 Final Report, March 2005
6. Hopkinson, R. HL, Ferturesonant Overvoltage Control Based on INA Tests on Three Phase Delta Wye Transformer Banks," IEEE Transactions on Power Apparatus and Systems, vol.86, pp.1258-65. October 1967.
7. Article. Thervoluge Under voltage load Protection",website <http://www.nevonprojects.com/Over-voltage Under-voltage-load-protection.html>, last accessed 27 September 2015.
8. LAMARCHE, Paper, "Controlled Ferroresonant Technology". Volume 1, Issue2. November 2006.

9. Mohammad Shah Alamgir and Sumit Dev, "Design and Implementation of an Automatic Voltage Regulator with a Great Precision and Proper Hysteresis", Vol.75, year 2015,
10. Endeavour Energy Power Quality & Reliability Centre,"Voltage Sag Mitigation, Technical Note 11. August 2012
11. Math H. J. Bollen, Understanding Power Quality Problems Voltage Sags and Interruptions", 2000, New Jersey, John Wiley & Sons.
12. All about Circuits, Voltage Regulation, Available from: http://www.allaboutcircuits.com/v2/chipt_9.6.html lastAccessed 29 September