

SMART CYCLE

Udhaya Shankar C¹, Roophika C S², Ridu Varshini N³, Keerthana B⁴

¹Associate Professor, Department of Electrical and Electronics Engineering, Kumaraguru College of Technology [autonomous], Coimbatore, India

^{2,3,4}Department of Electrical and Electronics Engineering, Kumaraguru College of Technology [autonomous], Coimbatore, India

Abstract - Today, million people rely on automobile as their primary means of transportation. Compared to other modes of transportation, cars are the most efficient and convenient means of transportation. Unfortunately, most cars use fossil fuels and are very expensive to maintain in the current situation. So, E-cycle that looks a lot like a regular bike, with an external electric motor instead of pedaling power. In some cases, pressing the accelerator pedal will start the engine, compared to regular cycles, it is far effective for transportation. Electric bicycles are usually an alternative to both traditional bicycles and cars. This project aims to Fabricate an Electric Bicycle, which can be used for commercial purpose without muscular power. Here, the E-cycle is fabricated with the help of converter to boost the voltage from the battery.

Key Words: SEPIC, LEAD ACID BATTERY, PEDAL ASSISTANT, DC-DC CONVERTER

1. INTRODUCTION

Due to the rapidly dwindling resources of petrol, diesel, and natural gas, the energy crisis is one of the primary worries in today's globe. In addition, environmental degradation is an additional component that contributes to resource depletion, which is a concerning warning. So, hereby our project provides a good solution for these problems. [1] Electric cycle, which is very efficient mode of transportation that comes with more advantages compared to traditional cycles and other motor vehicles. There are many types of bicycle available in market such as normal cycle that people need to peddle for it to move, motorized bicycle that uses fuel as its prime power and electric bicycle that can be sufficient for an hour, because of some weakness in the existence system, electric cycles came into picture.[2] Though there are electric cars and bikes available in the market, unfortunately electric cars tend to be expensive, mainly due to the cost of battery assembly. A four seater electric car being used to transport a single person is also wasteful of energy and also they requires parking spaces, costly, requires insurance and also need high maintenance.[3]

Less expensive E-bikes used bulky lead acid batteries because of the huge growth they started using NiMH, NiCad and Li-ion batteries which was lighter and denser capacity batteries. These were used mainly because of the

performance; however, there is an increase in range and speed with the new developments towards the E-bike. In 2007 E-bikes were increased by 10 to 30 percent of all two wheeled vehicles in major cities. In countries with dominant gasoline two-wheeler mode split, replacing those vehicles with electric bicycle could improve air quality and reduce greenhouse gases.

2. PROPOSED WORK

In general electric cycles comes with two 12V batteries which drives 24V dc motor, here we have been implementing this using a converter to replace a single 12V battery to reduce the weight of the bicycle.

So here SEPIC(single ended primary inductor-converter)is used to boost the voltage of a single 12V battery to give sufficient power to drive the motor.

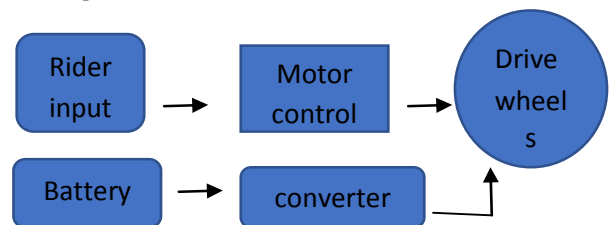

Fig -1: Block diagram

2.1 Methodology

Here, as described in figure -1.1,we have used SEPIC converter to boost the voltage from battery to the motor which drives the wheels.

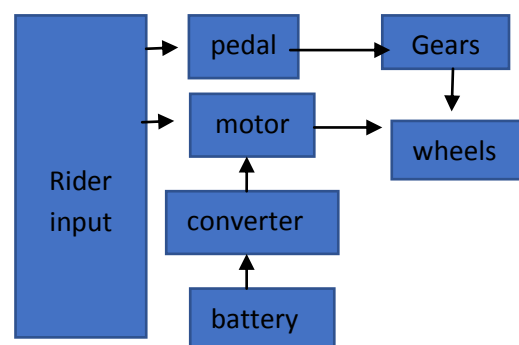

Fig -2 : Methodology

3. DESCRIPTION OF THE COMPONENTS

- Dc motor
- Bicycle
- E-brake
- SEPIC converter
- Lead Acid battery
- Accelerator
- Pulley

3.1 Dc motor

A brushed DC electric motor is an internally commutated electric designed to be run from a direct current power source. Brushed motors were the first commercially significant use of electric power to drive mechanical energy, and DC distribution systems have been used to power motors in commercial and industrial facilities for more than a century. The operating voltage or the strength of the magnetic field can be changed to change the speed of brushed DC motors. The speed and torque characteristics of a brushed motor can be changed depending on how the field is connected to the power source to produce stable speed or speed that is inversely proportional to the mechanical load. Generally, the rotational speed of a DC motor is proportional to the EMF in its coil (the voltage applied to it minus voltage lost on its resistance), and the torque is proportional to the current.

The reason brushed dc motor was chosen because the cost was the one of the main reasons as the project focused on an economical and user friendly so the motor had to be low cost and easy to work with minimum circuitry design to achieve the required results in this case rotation of the motor with variable speed. And the brushed dc motor has a higher torque at high load conduction so we decided to go with a brushed dc motor.

3.2 E-brake

The e-brakes are often called cut out switches and the overall effect is exactly that, the motor cuts off. The e-brake switch does not actually cut power to make this happen, what it does is it makes a connection and sends power to the controller, just the opposite of what "cut off switch" implies.

3.3 LEAD-ACID BATTERY

The lead-acid battery is the earliest type of rechargeable battery, yet still most widely used, despite having a very low energy-to-weight ratio and a low energy-to-volume ratio, Because of its ability to supply strong surge currents, the cells have a high power-to-weight ratio. These characteristics, together with their inexpensive cost, make them appealing for use in automobile starter motors to generate the high current necessary. Lead-acid batteries are

frequently utilised because they are less expensive than newer technology.

4. WORK DONE

4.1 Study of SEPIC

The single-ended primary-inductor converter (SEPIC) is a DC/DC converter that permits the electrical potential at its output to be more, less, or equal to the electrical potential at its input. The duty cycle of the control switch regulates the SEPIC's output.

A high frequency pulse is used to swiftly turn on and off a MOSFET in all dc-dc converters. What makes the SEPIC converter superior is what it does as a result of this. When the pulse is high/the MOSFET is on in the SEPIC, the input voltage charges inductor 1 and capacitor 1 charges inductor 2. The output is maintained by capacitor 2 while the diode is turned off. The inductors output through the diode to the load and the capacitors are charged when the pulse is low/the MOSFET is off. The output will be higher if the pulse is low for a bigger percentage of the time (duty cycle). This is due to the fact that the longer the inductors charge, the higher the voltage. The capacitors will not be able to charge if the pulse lasts too long, and the converter will fail.

4.2 Simulation results

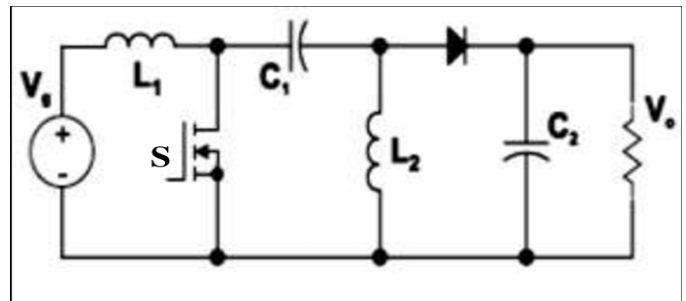

Fig- 4.2.1 circuit diagram

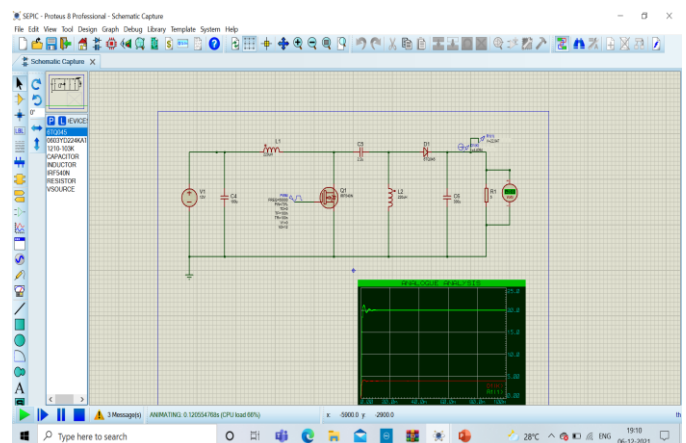

Fig 4.2.2- simulation result

4.3 ADVANTAGES OF SEPIC

- SEPIC – a buck boost converter.
- Provides non inverted output, unlike as Cuk and buck boost converters.
- The output of SEPIC is controlled by the duty cycle.
- Heat dissipation is less
- Greater efficiency
- less loss because of use of single switch
- provides stable output compared to other converters

5. RESULT

The bicycle is equipped with an electric motor which is mounted to the rear axle which drives the rear wheel. The electric motor that propels the bicycle is powered by a battery pack. A control unit controls the amount of current flow to the motor from the battery to vary the speed using a variable resistance assembly (accelerator). Recharging circuit consists of two parts motor and a circuit board.

To enhance the voltage fed to the dc motor sepic converter is used here which is used to drive the cycle without muscular power. By reducing a battery nearly 3.5 kg of weight is reduced but the thing to be noted here is that the efficiency will be quite low compared to the existing model, but on the other hand, the weight of the cycle is greatly reduced and make it easy for usage.

6. CONCLUSION

The range of the bicycle ride was successfully increased with the help of the E-bike kit by using a brushed DC motor to drive the bicycle when needed and powered by a lead acid battery. The whole unit was controlled by an **impact** unit.

As it is having two modes of drive electric and manual pedaling it will significantly improve rider's health than motorbikes and reduces rider fatigue than traditional bicycle. E-bikes are claimed to have a significantly lower environmental impact than conventional automobiles and generally seen as eco-friendly.

7. FUTURE SCOPE

The following are some of the enhancements that can be made to our project in the future:

- Lithium-Ion Battery
- Self-Recharging

- Regenerative Braking

- Range Extender

- Programmable ECU

In today's market the lithium ion batteries are expensive and hazardous, in the future due to improvement in technology the cost and safety could help in utilizing it to E-Bike.

Self-recharging is not efficient and reliable in today's technology which can be improved in the future.

Regenerative braking is still used only on high end cars and bikes in the near future this technology can be used on all forms of automobiles and E-Bikes.

Range extender by utilizing self-recharging and regenerative braking which could help to increase the range of hybrid and electric vehicles.

The ECU we are using is a pre-programmed circuit board which cannot be modified but in future it can be changed by utilizing a programmable ECU.

REFERENCES

1. Vivek V Kumar, Karthik A, "Design and Implementation of Electric Assisted Bicycle with Self Recharging Mechanism" International Conference on Innovations & Advances in Science, Engineering and Technology [IC - IASET 2014]
2. Deep R Prajapati, Kunjan Shinde, Abhishek Mhaske, "Design and Fabrication of Electric Bike."
3. Boopathi S, Saranya A, Raghuraman S, "Design and Fabrication of Low-Cost Electric Bicycle"
4. Christian Gorenflo, Ivan Rios, Lukasz Golab, "Usage Patterns of Electric Bicycles: An Analysis of the We-Bike Project."
5. Ian Vince McLoughlin, I. Komang Narendra, Leong Hai Koh, "Campus Mobility for the Future: The Electric Bicycle"
6. C. Abagnalea, M. Cardoneb, P. Iodicea, R. Marialtoc, S. Stranoa, "Design and Development of an Innovative E-Bike" 71st Conference of the Italian Thermal Machines Engineering Association, ATI2016, 14-16 September 2016, Turin, Italy.
7. Mitesh M. Trivedi, Manish K. Budhvani, Kuldeep M. Sapovadiya, "Design & Development of E-Bike - A Review"