

Battery Management System - Hardware Design

Raj Patel¹, Seema Talmale²

¹Student, Dept of Electronics Engineering, K.J. Somaiya College of Engineering, Mumbai, India

²Professor, Dept of Electronics Engineering, K.J. Somaiya College of Engineering, Mumbai, India

Abstract — Battery management system (BMS) is used in Electric Vehicles (EV) and Energy Storage Systems to monitor and control the charging and discharging of rechargeable batteries. BMS keeps the battery safe and reliable and increases the stability without going into damaging state. The state of the battery is maintained by monitoring voltage, current, and the ambient temperature. For monitoring purpose, data is obtained from various analog/digital sensors and processed through the microcontroller.

Introduction

In the imminent future, Electric Vehicles will be the leading form of transportation. Lithium-based rechargeable batteries will be widely used. These battery packs will need to be constantly monitored and managed in order to maintain the safety, efficiency and reliability of the whole electric vehicle. A battery management system consists of: (1) a battery level monitoring system (2) optimal charging algorithm and (3) a cell/thermal balancing circuitry. The voltage, current and temperature measurements are used to estimate all crucial states and parameters of the battery system, such as the battery impedance and capacity, state of health, state of charge, and the remaining useful life.

BMS

As shown in the Figure 1 below, the BMS consists of mainly three blocks which are: the Battery Monitoring Unit (BMU), the Battery Control Unit (BCU) and the Vehicle Control Unit (VCU). The BMS also interfaces with the rest of the vehicle energy management systems. Rest of the configurations are embedded within the BMS.

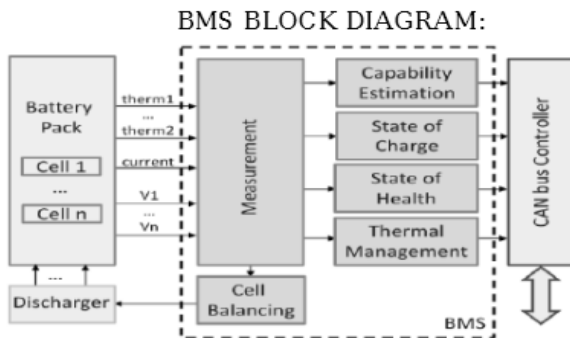

Figure 1: BMS Block Diagram

SOC Determination

The state of charge(SOC) is defined as the ratio of available capacity- Q(t), and the maximum possible charge that can be stored in a battery. State of charge plays an important role in a battery management system to examine the state of the battery which aids it in operating within the safe operation range by controlling the charging and discharging. The life span of the battery is also improved. The SOC is computed by using the given equation-

$$SOC=1- (\int idt /Cn)$$

Where,

I =Current

Cn=Max capacity the battery can hold

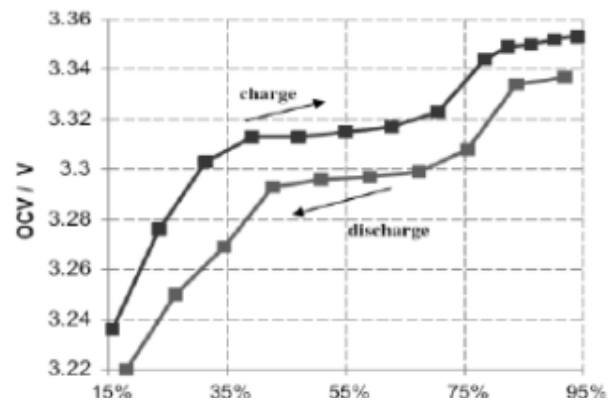

Figure 2: SOC during charging and discharging

SOH DETERMINATION

The State of Health (SOH) of a battery is the difference between a battery being surveyed and a new battery. It is the ratio of maximum battery charge to its rated capacity, and is shown as percentage seen below:

$$SOH/\%=100(Q_{max}/Cr)$$

Where,

Q_{max}/mAh= The maximum charge available of the battery

Cr= The rated capacity

Thermal Management

Thermal management plays a vital role in Li-ion systems because, the stability of the electrodes depend on the temperature within the cell and its effects on the volatile organic solvents that make up the electrolyte. Selected solvents have a boiling point at 90°C and any increase above 90°C would boil off the solvent. Hence, increasing the cell's internal pressure, and forcing the solvent to vent. Thus preventing such excessive rise in temperature helps preserve the integrity of the cells.

BATTERY SOC MODELING

The SOC is defined as the rated capacity of a new cell. As the cell ages, the cell capacity reduces. It is also affected by the discharge rate and temperature. At the end of the cell's life the actual capacity will be approaching only 80% of its rated capacity. In this case, even if the cell is fully charged, its SOC would only be 80%. For an accurate estimate the ageing and environmental factors have to be taken into account. If the SOC reference is also defined as the current fully charged capacity of the cell, then, the adjustment factors would have to be applied to the rated capacity to determine a new reference capacity.

The SOC of a fully charged cell is 100% but it will have a capacity of only 80% of a new cell. For cell balancing, it is crucial to know the SOC of any cell relative to the other cells. The ageing and environmental adjustments can be dismissed as all the cells will have been subjected to the same influences during their life cycle.

$$\ln * T_i = \text{constant}$$

Where,

- I: The discharge current (ampere)
- n: The battery constant (usually n=1.35)
- Ti: Discharge time at current I(second)

The Peukert relationship can be written as:

$$C_1 = C_2 * \left(\frac{I_2}{I_1}\right)^{(n-1)}$$

Where,

- C1, C2: The discharge rates at different discharge rate states.
- I1, I2: The current at the two different discharge rate states.

At a constant discharge rate, the battery SOC is given as:

$$SOC = 1 - \left(\frac{I * \text{Time}}{C}\right)$$

The current and discharge rate (C1 and I1) should be known for non-constant discharge rates. Given the current at the present time step I2, the corresponding discharge rate is calculated using equation for C1 and plugged into an incremental form of an equation for SOC. The incremental change in the battery ΔSOC can be given as:

$$\Delta SOC = I_2 \left[\frac{\Delta t / 3600}{C_1 * \left(\frac{I_2}{I_1}\right)^{(n-1)}} \right]$$

BMS HARDWARE DESIGN

The hardware design consists of a Master Board with the microcontroller that controls the BMS. In this board AVR128DA64 microcontroller is being used. This microcontroller of the AVR DA family makes use of the AVR CPU with a hardware multiplier, running at a speed of up to 24 MHz, with a 128 KB of Flash memory, 16 KB of Static RAM, and 512B of EEPROM. The AVR128DA64 is an adaptable and low power architecture including an event system, smart analog features, advanced digital peripherals and a Peripheral Touch Controller (PTC). The Master Board consists of the microcontroller, power and control circuitry. As the master board is powered using Low Voltage (LV) battery, it needs to be further stepped down to a certain voltage for the microcontrollers and other integrated circuits. For voltage step down, low power voltage regulators or buck converters are used. Various communication circuits like CANBUS, RS485, RS232 and Ethernet are present on the board. These circuits communicate with the microcontroller using I2C, SPI and UART protocols. CANBUS is widely used in automobile industry for communication. Hence the data of BMS and battery balancing can be sent to the main Vehicle Control Unit (VCU) directly over CANBUS. This VCU later controls the whole vehicular system which includes the BMS, BCU and other peripherals that are used. The board also consists of Real Time Clock and SD Card for real time monitoring and data logging.

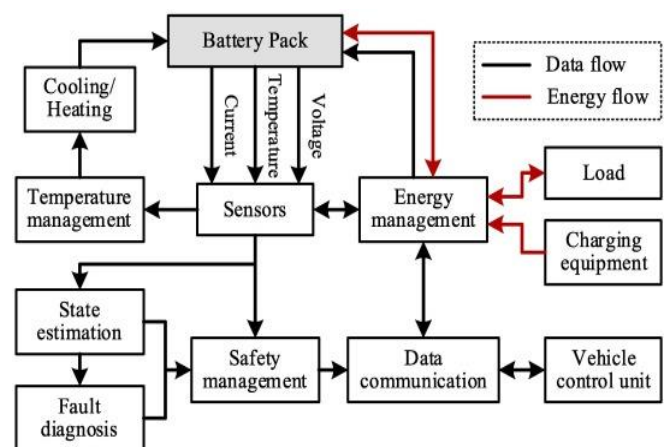

Figure 3: EV Block Diagram

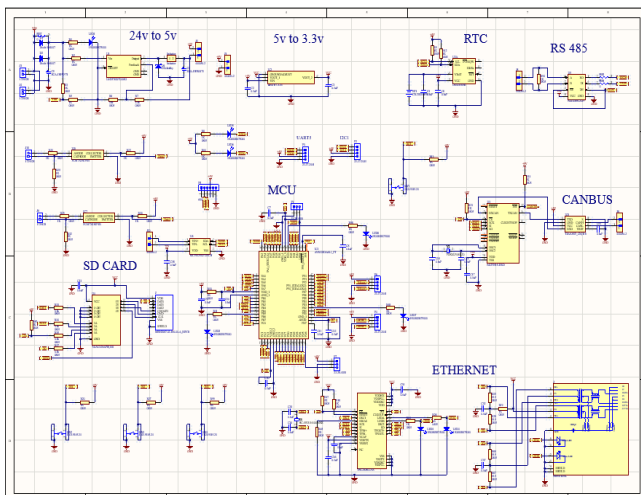

Figure 4: Schematic of the Master Board

The control circuitry consists of feedback and control systems which includes cell voltage feedback, temperature feedback and power mosfets to control the charging and discharging of the cells. The voltage feedback can be taken by using high precision voltage sensors or for prototyping one can use a simple voltage divider circuit. The temperature feedback is taken either by thermistors, thermocouples or RTDs. For isolation purpose, opt couplers are used in the circuit to control other peripheral components. The battery balancing board communicates through iso SPI communication protocol. It is a bidirectional Serial Peripheral Interface (SPI) communication between any two isolated devices through a single twisted-pair connection. The logic states are encoded by the transmitting LTC6820 and are transferred through an isolation barrier to another LTC6820. The receiving LTC6820 decodes the data and drives the slave bus to the appropriate logic states. A pulse transformer is used in the isolation bridge to achieve hundreds of volts of isolation.

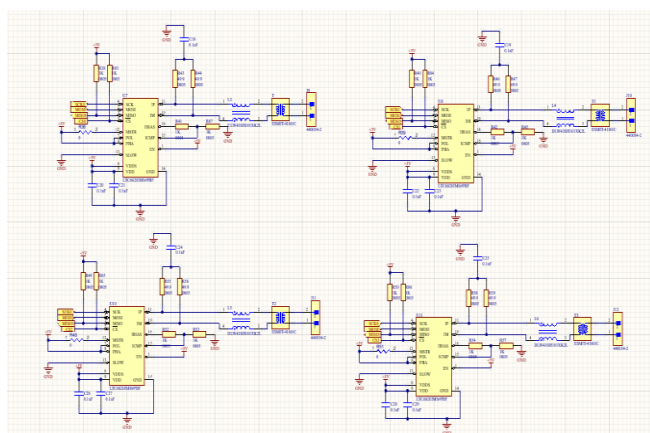

Figure 5: Schematic of LTC6820 isoSPI circuit

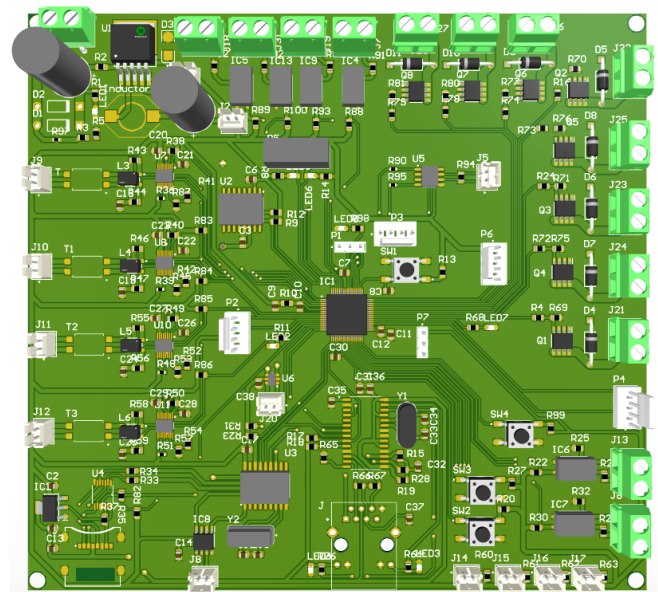

Figure 6: The Master Board PCB

BALANCING BOARD

The balancing board consists of LTC6813. It is a multi-cell battery stack monitor. Value of 18 series connected battery cells can be monitored with a total measurement error of less than 2.2mV. A number of LTC6813 devices can be connected in series, providing the simultaneous cell monitoring of long, high voltage battery strings. Each LTC6813 has an isoSPI interface for high speed, RF immunity, and long distance communications. Multiple devices are connected in a daisy chain formation with one host processor connection for all devices. The daisy chain operates bidirectionally, ensuring communication integrity.

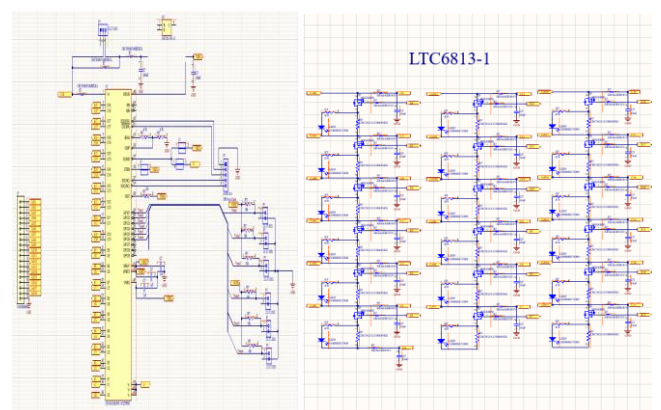

Figure 7: Schematic of Battery Balancing circuit

Figure 7 shows the circuit diagram of LTC6813 connections with different cells. The data obtained from these cells are sent over the isoSPI network to the master board using LTC6820.

Conclusion

Major battery management system technologies are comprehensively discussed in this paper. The key focus of this paper is to give a brief idea about State of Charge, State of Health, Thermal management, and Battery SOC modeling. A version of the master board for BMS was designed. This system allows to program different control signals and peripherals from the feedback given by the battery pack. The implementation of the AVR based microcontroller was done along with the cell balancing and isoSPI communication ICs. Various other communication protocol facilities were given for smooth functioning and wireless control of the BMS. Data logging feature proved to be very helpful. Different types of cell balancing techniques were discussed. Overall the BMS proves to be an essential part of energy storage systems.

References

1. Cabrera, Jose & Vega, Aurelio & Tobajas, Félix & Deniz, Victor & Fabelo, Himar. (2014). Design of a reconfigurable Li-Ion Battery Management System (BMS). 1-6. 10.1109/TAEE.2014.6900162.
2. John Chatzakis, Kostas Kalaitzakis, Nicholas C. Voulgaris and Stefanos N. Manias, "Designing a New Generalized Battery Management System", IEEE Trans. On I.E., VOL. 50, NO. 5, Oct. 2003.
3. Designing a New Generalized Battery Management System. John Chatzakis, Kostas Kalaitzakis, Nicholas C. Voulgaris, and Stefanos N. Manias, Senior Member, IEEE Transactions on Industrial Electronics, Vol. 50, No. 5, October 2003
4. Liu, K.; Li, K.; Peng, Q.; Zhang, C. A brief review on key technologies in the battery management system of electric vehicles. *Front. Mech. Eng.* 2019, 14, 47–64.
5. Karmi, G.; Li, X. Thermal management of Lithium-ion batteries for electric vehicles. *Int. J. Energy Res.* 2013, 37, 13-24.
6. Guo, Z.; Qiu, X.; Hou, G.; Liaw, B.Y.; Zhang, C. State of health estimation for lithium ion batteries based on charging curves. *J. Power Sources* 2014, 249, 457-462
7. H.J. Bergveld, *Battery Management Systems Design by Modeling* 2001, ISBN 9074445-51-9