

Review of Wireless Charging Technologies for Electric Vehicles

¹Raghavendra L, ²Sathish K R, ³Priyadarshini L

¹Associate Prof., ²Assistant Prof., ³Assistant Prof.

Department of Electrical and Electronics Engineering, ATME College of Engineering, Mysuru, Karnataka, India

Abstract

Electric vehicles will reduce greenhouse gas emissions while simultaneously reducing petrol prices. A variety of charging networks must be built in a user-friendly environment to boost the adoption of electric vehicles. WEVCS (Wireless Electric Vehicle Charging Systems) may be a feasible alternative to using a plug to charge electric vehicles. This paper describes the present state of wireless power transfer technologies for electric vehicles. WEVCS have been related to health and safety problems, which have been investigated in connection to the development of current international standards. The static and dynamic WEVCS applications are reviewed, as well as current advancements with features from universities, research laboratories, and industry. Furthermore, future concept-based WEVCS, such as "Vehicle-to-Grid (V2G)" and "in-wheel" Wireless Charging Systems (WCS), are reviewed and examined, with qualitative comparisons to other existing technology.

1. Introduction:

The transportation industry is a major contributor to global climate change and CO₂ emissions [1]. With transportation accounting for almost 60% of global oil usage in 2017, the demand for a clean alternative is urgent [2]. Electric vehicles (EVs) are a critical component in the transition to a clean energy civilization [3]. EVs have been advanced tremendously in terms of performance and range. Various models are commercially available on the current automotive market. With a rising number of EVs on the road, determining how to charge them properly and efficiently remains a challenge, having a substantial influence on power networks [4], [5]. Almost majority of the existing EVs are charged by electric cables. Cables must be physically linked to the EVs for charging, whether at home or on the roadway. These strong connections might be quite dangerous, especially in inclement weather. Furthermore, they may produce sparking when plugged in and unplugged, which severely limits the usage of EVs in some situations, such as near petrol stations and airports. Wireless charging, which is more versatile and convenient, has gotten a lot of attention. Several firms, including Tesla, BMW, and Nissan, have begun to build wirelessly charged electric vehicles that do not require cumbersome connections. The wireless (inductive) link, rather than a physical cable connection, successfully prevents sparking. Wireless charging also gives up new opportunities for dynamic charging, such as charging while driving.

In high-power applications, such as EVs [6] and plug-in electric vehicles (PEVs) [7] in stationary [8] applications, Wireless Charging Systems (WCS) have been suggested. WCS can provide more benefits in terms of simplicity, dependability, and user friendliness than plugin charging solutions [9]. WCS have an issue or restriction in that they can only be used when the automobile is parked or in stationary modes, such as at parking lots, garages, or at traffic lights. Furthermore, stationary WCS have a number of obstacles, including EMC concerns, restricted power transmission, bulky constructions, shorter range, and greater efficiency [10–12]. The dynamic mode of operation of the WCS for EVs has been investigated in order to increase the two areas of range and sufficient battery storage volume [13,14]. This technology enables battery storage devices to be charged while the vehicle is in motion.

The vehicle uses less expensive battery storage space and has a longer range of travel [15]. However, before being generally accepted, a dynamic WCS must overcome two major obstacles: a significant air gap and coil misalignment. The coil alignment and air-gap distance between the source and receiver affect power transfer efficiency [10,16]. For compact passenger vehicles, the usual air-gap distance ranges from 150 to 300 mm, whereas it may grow for bigger vehicles. Because the automobile is driven automatically in dynamic mode, aligning the ideal driving position on the transmitter coil is simple. On both the transmitting and receiving sides, several compensation strategies, such as series and parallel combinations, are used to decrease parasitic losses and increase system efficiency [17,18]. The fundamental functioning of WCS for EVs, including power

transfer mechanisms, is examined in this review study. In order to optimize power transmission efficiency, a range of wireless transformer architectures are also discussed. Current advances in the dynamic and static modes of WEVCS in both the corporate and academic sectors are also discussed in this paper.

2. Wireless charging system for EVs

2.1. Basic operating principle

Figure 1 shows the fundamental block diagram of the static WCS for EVs. AC mains from the grid are transformed into high frequency (HF) AC using AC/DC and DC/AC converters to facilitate power transfer from the transmission coil to the reception coil. On both the transmitting and receiving sides, compensatory topologies based on series and parallel combinations are used to increase overall system efficiency [19,20]. The oscillating magnetic flux fields are converted to HF AC by the receiving coil, which is usually positioned below the car. The HF AC is then converted to a steady DC supply that the on-board batteries can utilize. To avoid any health and safety issues and to assure steady operation, the power control, communications, and battery management system (BMS) are also integrated. To eliminate any harmful leakage fluxes and enhance magnetic flux distribution, magnetic planar ferrite plates are used on both the transmitter and receiver sides.

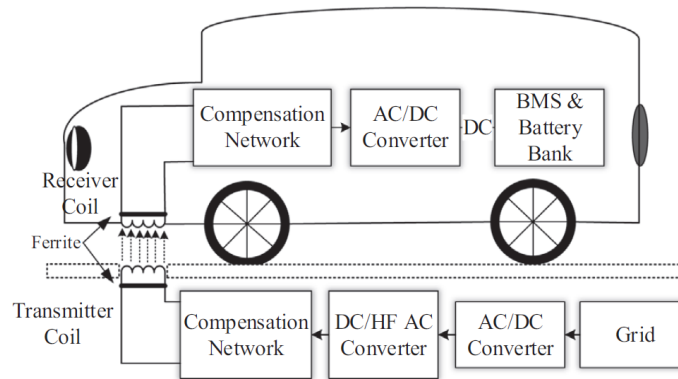

Fig. 1. Basic block diagram of static wireless charging system for EVs.

2.2 Health and safety concerns

WEVCS provide a number of benefits over traditional plug-in charging devices. It does, however, come with three main health and safety concerns: electrical, magnetic, and fire hazards. WEVCS is a high-current, high-voltage system. This might result in an electrical shock hazard if the gadget malfunctions or is accidentally damaged as a consequence of environmental conditions (hot or cold) or physical damage. Furthermore, level 1 (3.7 kW) and level 2 (7.7 kW) WEVCS are commonly seen in homes, dormitories, and general parking places, with transmitter charging pads embedded in the ground or concrete. To give protection and avoid any life-threatening scenarios, this type of setup needs additional safety regulations.

Magnetic fluxes produced at high power levels may exceed the minimal requirements and limits established by standards authorities, posing a risk to the general public. Electromagnetic compatibility (EMC) and electromagnetic interference (EMI) must be investigated to address the challenge of technological safety features in order to safeguard the surrounding plants and animals. Furthermore, strong power transmission from the transmitter to the receiver's charging pads occurs over huge air gaps ranging from 150 mm to 300 mm and at frequencies ranging from a few kilohertz to a few megahertz. As a result of the enormous air gaps, high frequency leakage fluxes are generated. The amount of such exposure fluxes must be below or satisfy the human exposure limits (IEEE C.95.1 2005, For a range of human body parts, see ICNIRP 1998 (0 Hz-300 GHz) and ICNIRP 2010 (0 Hz-100 kHz) [21]. Maximum permissible exposure (MPE) and specific absorption ratio (SAR) have been used to define appropriate limits [22]. If a person with health monitoring equipment, such as a pacemaker, is exposed to leakage fluxes, they may experience health problems. This may happen if you're sitting in the car when it's wireless, or if you're walking or standing near the wireless charging pads. The influence of EMC and EMI concerns on a range of magnetic ferrite forms has

been verified using FEM simulation to tackle such problems [23]. Furthermore, several continuing research and development prototypes have been built and tested to make the WEVCS more user-friendly.

2.3 Health and safety standards

It is important to specify standards for power level, efficiency, operating frequency, EMC, EMI, safety and testing for the research and commercialization of the WEVCS in order to provide a user-friendly environment for the technology. Many international organisation and task forces, including the Society of Automotive Engineers (SAE), the International Electro Technical Commission (IEC), the Institute of Electrical and Electronics Engineers (IEEE) and Underwriters Laboratories (UL) have been collaborating with universities, governments, institutes, and the EV industry to enable commercialization. Regarding EMF limits, EMC levels, and compatibility with health monitoring medical implanted devices like pacemakers, the International Commission on Non-Ionizing Radiation Protection (ICNIRP), Federal Communications Commission (FCC), and American Association of Medical Instrumentation (AAMI) based electromagnetic societies are referred to [24]. It's unfortunate that features of standards and interoperability haven't been fully established because there are some substantial roadblocks to this technology's application.

3. Challenges and hurdles to the deployment of WEVCS

Despite the fact that WEVCS provide more benefits than plug-in chargers, obstacles like as health and safety, budgets, power range limits, infrastructure development, and maintenance must be solved before deployment can take place. Sections 2.2 and 2.3, respectively, have highlighted health and safety problems such as EMC, fire, and electrical dangers with the recent development of the standards. The power range limits of the WEVCS, as compared to plug-in chargers, is another key barrier to widespread acceptability. The AC Level 1 (1.4–1.9 kW) and 2 (3.3–20 kW) on-board charging systems have a charging range of 2–20 miles per hour. In 20 minutes, DC rapid charging (up to 100 kW) may provide 60 to 80 miles of range [26–28]. According to the new J2954 specifications, WPT classes for static mode can go up to 22 kW. They're still in the early stages of research and development. To address these challenges, a sophisticated network of static and dynamic wireless charging stations must be installed on the highways. Due to incompatibility with present arrangements, such a network necessitates the building of new infrastructure. Because the beginning cost of WEVCS Level 1 (3.3 kW) might be around \$2470 [25], this can result in increased financial obligations for governmental organisation.

With a charging power level of 200 kW, the dynamic WCS can cost up to A\$2M/km/lane [29]. For emerging and poor nations, this is expensive. Because the building is such a large investment, good maintenance is essential to avoid severe losses due to incorrect handling, wear and tear, and limits of foreign object identification (FOI) [30]. Overall, a number of experimental using simulation scenarios-based techniques are offered to build user-friendly international standards that can assure worldwide uniformity in order to effectively deploy WEVCS.

4. Future application concepts of WEVCS

4.1. Wireless vehicle to grid (W-V2G)

The rapid growth of PEVs has necessitated the development of quick and efficient charging and power transfer techniques. As the number of PEVs grows, so does the demand for electricity from distribution networks, which has a negative influence on them. Renewable energy sources (RES) have been introduced to the microgrid to compensate for the increased power demand, although they have limited support facilities. The vehicle-to-grid (V2G) idea can provide a solution for charging and discharging to the distribution network, as well as improved scheduling [8]. The bi-directional power transmission application for PEVs with wireless and plug-In modes is shown in Figure 2. EVs with an on-board bi-directional charger in the plug-In V2G mode allow the user to connect to the grid or to their house at peak hours. The car is charged from an AC wall socket during off-peak hours. To ensure additional protection to the user, AC is converted through DC and supplied to an isolated DC/DC converter. BMS, control and protection, and a bi-directional DC/DC converter are used to send converted DC to a battery. When charging the battery bank, this converter acts in buck (step-down mode), and when discharging, it operates in boost mode (in order to increase power level). Figure 2 illustrates this (b). The disadvantage of this method is that it necessitates physical contact and human handling to charge or discharge the electric vehicles, which introduces extra risks such as electric shock and trip hazards. To address these issues, a wireless V2G has been developed, as illustrated in Fig. 2. (a).

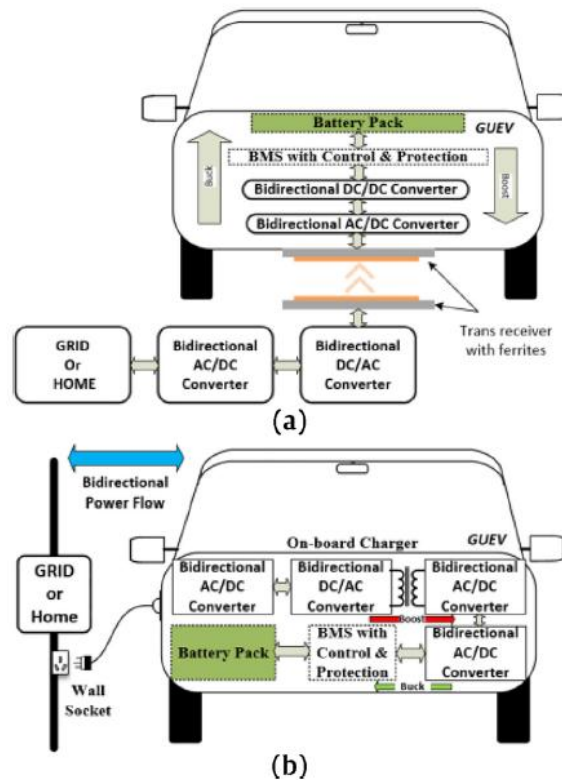

Fig. 2. Bidirectional power transfer applications (a) wireless V2G (b) plug-In V2G.

The comparison between wireless V2G and plug-in V2G is shown in Table 1. Unlike plug-in V2G, the primary side of the wireless transformer is integrated with bidirectional power converters on the road or parking surface. The receiver coil is positioned beneath the vehicle, while the remaining bi-directional power converters are mounted in the body. The design is self-contained and uses a wireless transformer to offer further isolation between the source and receiver sides. In static or dynamic modes, surplus energy can be sent to PEVs to relieve stress or received energy to rectify peak demand energy. Furthermore, in a dynamic V2G operation, this technology can serve as a buffer or backup for mobile energy storage.

Table.1: Comparison between Plug-In V2G and Wireless V2G

Features	Plug-In V2G	Wireless V2G
Method	Traditional Conductive	Wireless Power Transfer
Convenience	Medium	Very High
Power Transfer Efficiency	>90%	>90%
Power Transfer Capability	High	High
Position Sensitivity	N/A	Medium to High
Connection Compatibility	Variety of standards shapes and sizes	No Plugs
Health and Safety: Isolation	Compulsory on-board transformer	Wireless Transformer
Electric Shock Hazard	Medium to high	Low to medium
EMI	Low	Medium to high
Air-gap Sensitivity	N/A	Medium to High
Operating frequency	16–100 kHz	81.9–90 kHz
Operating Function	Manual	Automatic
Power Transfer Scheduling	Manual	Automatic

4.2. In Wheel WCS

4.2.1. Configuration of IW-WCS

EMC issues, limited power transmission, bulky constructions, and improved efficiency are among obstacles that stationary WEVCS confront [6,31,32]. Additionally, the coil alignment and air-gap distance between the source and receiver affect power transfer efficiency [31,33]. For compact passenger vehicles, the usual air-gap distance ranges from 150 to 300 mm, whereas it may grow for bigger vehicles. The alignment problem can be handled with the use of sensor technology or parking assistance, which can direct the driver to the coil's centre. Before becoming more generally adopted, Dynamic-WEVCS technology must overcome two major obstacles: a huge air gap and coil misalignment. The misalignment problem can be overcome to some extent due to the large number of source coils. In-wheel WCS (IW-WCS) has been developed for stationary and dynamic applications to address air-gap issues in the WEVCS. It is also less dependent on receiving coil shape and placement standardization, as shown in research publications [17,34–36]. IW-WCS, both static and dynamic, are future technologies that may be utilized to charge EVs or PHEVs while stationary or moving. IW-WCS provides substantial benefits over existing quasi-dynamic or dynamic-WCS due to decreased air-gaps and greater coupling efficiency between the transmitter and receiver. The multiple source or source coils, like other WEVCS, are usually positioned beneath the road surface.

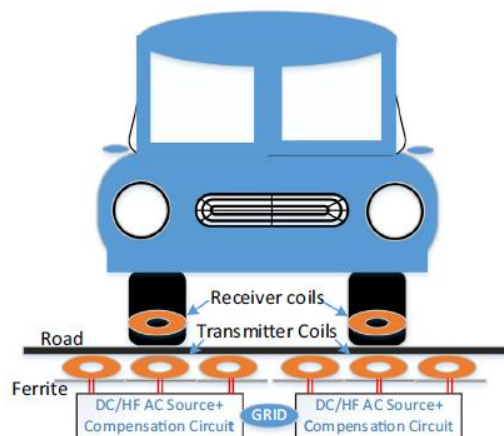

Fig. 3. Schematic diagram of Static and Dynamic In-Wheel WCS.

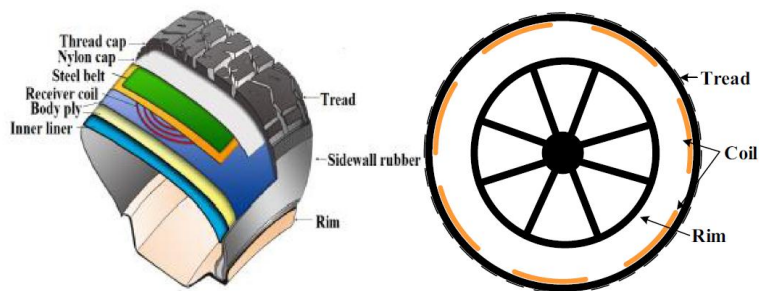

Fig. 4. In-Wheel WCS (a) internal coil placement (b) coil arrangement.

Figure 3 shows the IW-WCS basic schematic diagram for stationary and dynamic applications. A compensating circuit connects the primary windings to the main grid source, which is transformed to a high frequency (HF) AC source. The secondary coils of the IW-WCS are integrated into the tyre construction, unlike other WEVCS. In compared to conventional static- or dynamic-WEVCS, the air gap between the source and receiver coils in an IW-WCS is lower. The wireless transformer coils, power supply, and internal structure of the tyre are the three primary structural components of an IW-WCS, all of which must be properly built in order to create an efficient static and dynamic IW-WCS. Figure 4 shows a detailed internal positioning of the

receiver coils. Inside the tyre, many receiver coils are arranged in a parallel configuration. The benefit of this design is that only the receiver coil that is in touch with the transmitter is activated. Multiple receiver coils may be triggered in some circumstances when horizontal misalignment occurs. These are the devices that deliver electricity to the battery bank or load. A resonant capacitor, rectifier, and filtering circuits are all included in each receiver coil. The receiver coils array should be placed between the steel belt and the body ply.

5. Conclusion

This work presents a foundational description of the WEVCS for fixed and dynamic applications using present research methods. Concerns about health and safety have been raised, and current global standards improvements have been presented to WEVCS. With state-of-the-art stationary and dynamic WEVCS, present research and development from a range of governmental and commercial organizations has been analyzed and summarized. Finally, future technologies that are emerging are evaluated. The most present breakthroughs in the field of WEVCS are discussed in this article.

6. Reference

1. International Energy Agency (IEA), "Global Energy & CO2 Status Report 2017," IEA, 2018.
2. "BP Energy Outlook 2017," 2017. [Online].
3. N. Adnan, S. M. Nordin, I. Rahman, P. Vasant and M. A. Noor, "An overview of electric vehicle technology: a vision towards sustainable transportation", *Intelligent Transportation and Planning: Breakthroughs in Research and Practice*, 2018.
4. S. Sachan and N. Adnan, "Stochastic charging of electric vehicles in smart power distribution grids", *Sustainable Cities and Society*, Vol. 40, pp. 91-100, 2018.
5. N. Adnan, S. M. Nordin and O. Althawadi, "Barriers towards widespread adoption of V2G technology in smart grid environment: from laboratories to commercialization", *Sustainable Interdependent Networks*, pp. 121-134, 2018.
6. K.A. Kalwar, M. Aamir, S. Mekhilef, Inductively coupled power transfer (ICPT) for electric vehicle charging – a review, *Renew. Sustain. Energy Rev.* 47 (2015) 462–475.
7. G. Ombach, Design considerations for wireless charging system for electric and plug-in hybrid vehicles, *Hybrid Electr. Vehicles Conf. 2013* (2013) 1–4.
8. D. Leskarac, C. Panchal, S. Stegen, J. Lu, PEV Charging Technologies and V2G on Distributed Systems and Utility Interfaces, in: J. Lu, J. Hossain (Eds.), *Vehicle-to-Grid: Linking Electric Vehicles to the Smart Grid*, The Institution of Engineering and Technology (IET), London, United Kingdom, 2015, pp. 157–209.
9. H. Barth, M. Jung, M. Braun, B. Schmülling, U. Reker, "Concept Evaluation of an Inductive Charging System for Electric Vehicles", Presented at the 3rd European Conference SmartGrids and E-Mobility, Munchen, Germany, 2011.
10. M. SangCheol, K. Bong-Chul, C. Shin-Young, A. Chi-Hyung, M. Gun-Woo, Analysis and design of a wireless power transfer system with an intermediate coil for high efficiency, *Indust. Electr., IEEE Trans.* 61 (2014) 5861–5870.
11. G.A. Covic, J.T. Boys, Inductive power transfer, *Proc. IEEE* 101 (2013) 1276–1289.
12. G.A. Covic, J.T. Boys, Modern trends in inductive power transfer for transportation applications. *Emerging and selected topics in power electronics, IEEE J.* 1 (2013) 28–41.
13. S. Lukic, Z. Pantic, Cutting the cord: static and dynamic inductive wireless charging of electric vehicles, *Electr. Magazine, IEEE* 1 (2013) 57–64.

14. M. Eghtesadi, Inductive Power Transfer to an Electric Vehicle-Analytical Model, Vehicular Technology Conference, 1990 IEEE 40th, 1990, pp. 100–104.
15. M. Fuller, Wireless charging in California: range, recharge, and vehicle electrification, *Trans. Res. Part C: Emerg. Technol.* 67 (2016) 343–356.
16. F. van der Pijl, P. Bauer, M. Castilla, Control method for wireless inductive energy transfer systems with relatively large air gap, *Industr. Electr., IEEE Trans.* 60 (2013) 382–390.
17. Q. Zhu, L. Wang, C. Liao, Compensate capacitor optimization for kilowatt-level magnetically resonant wireless charging system, *Indust. Electr., IEEE Trans.* (2014).
18. K. Jinwook, K. Do-Hyeon, P. Young-Jin, Analysis of capacitive impedance matching networks for simultaneous wireless power transfer to multiple devices, *Industr. Electr., IEEE Trans.* 62 (2015) 2807–2813.
19. J.L. Villa, J. Sallan, J.F.S. Osorio, A. Llombart, High-misalignment tolerant compensation topology For ICPT Systems, *IEEE Trans. Indust. Electr.* 59 (2012) 945–951.
20. K. Kalwar, S. Mekhilef, M. Seyedmahmoudian, B. Horan, Coil design for high misalignment tolerant inductive power transfer system for EV charging, *Energies* 9 (2016) 937.
21. (1998, April) Guidelines for limiting exposure to time-varying electric, magnetic, and electromagnetic fields. *Health Physics*.
22. R. Bashirullah, Wireless implants, *IEEE Microwave Mag.* 11 (2010) S14–S23.
23. C. Panchal, D. Leskarac, J. Lu, S. Stegen, Investigation of flux leakages and EMC problems in wireless charging systems for EV and other mobile applications, *Environ. Electromagnet. (CEEM), 2012 6th Asia-Pacific Conf.* (2012) 301–304.
24. J. Schneider, Developments in Wireless Power Transfer Standards and Regulations, *IEEE Stand. Educ. eMagaz.* 98 (2016).
25. (2017, 27 February). Plugless Power. Available: <https://www.pluglesspower.com/shop/>.
26. H. L. Chen. (2016, 27 February). Optocouplers Help Promote Safe, Efficient EV Charging Stations. Available: <http://electronicdesign.com/power/optocouplers-help-promote-safe-efficient-ev-charging-stations>.
27. T. Bohn. (2013, 27 February). PEV Charging Standards Status Including AC, DC and Wireless Technologies.
28. B. Berman. (2014, 27 February). Electric Vehicle Charging for Businesses.
29. A. Shekhar, V. Prasanth, P. Bauer, M. Bolech, Economic viability study of an on-road wireless charging system with a generic driving range estimation method, *Energies* 9 (2016) 76.
30. Vatsala, R. Hasan Khan, Y. Varshney, and A. Ahmad, Challenges and Potential Solutions for the Deployment of Wireless Charging Infrastructure for xEVs in India, 2017.
31. C. Liu, A.P. Hu, B. Wang, N.K.C. Nair, A capacitively coupled contactless matrix charging platform with soft switched transformer control, *IEEE Trans. Indust. Electr.* 60 (2013) 249–260.
32. J. Dai, D.C. Ludois, “Wireless electric vehicle charging via capacitive power transfer through a conformal bumper”, *IEEE Appl. Power Electr. Conf. Expos.(APEC) 2015* (2015) 3307–3313.

33. A.P. Hu, C. Liu, H.L. Li, A Novel Contactless Battery Charging System for Soccer Playing Robot, 2008 15th International Conference on Mechatronics and Machine Vision in Practice, 2008, pp. 646–650.
34. W. Li, High Frequency Wireless Power Transmission at low Frequency using Permanent Magnet Coupling Thesis, Master Applied Science, Vancouver,2007.
35. C. Qiu, K.T. Chau, C. Liu, C.C. Chan, Overview of wireless power transfer for electric vehicle charging, 2013 World Electric Vehicle Symposium and Exhibition (EVS27), 2013, pp. 1–9.
36. K.W. Klontz, A. Esser, R.R. Bacon, D.M. Divan, D.W. Novotny, R.D. Lorenz, An electric vehicle charging system with 'universal' inductive interface, Conf. Rec. Power Conv. Conf. - Yokohama 1993, 227–232.

BIOGRAPHIES



Raghavendra L
Associate Professor
Department of EEE
ATME College of Engineering, Mysuru, Karnataka.



Dr. Sathish K R
Assistant Professor
Department of EEE
ATME College of Engineering, Mysuru, Karnataka.



Priyadarshini L
Assistant Professor
Department of EEE
ATME College of Engineering, Mysuru, Karnataka.