

Automatic Car Parking System Using PLC

Veena Ghosalkar¹, Devayani Karedla², Jayesh Sawaratkar³, Saujeet Sarkar⁴, Mohini Kher⁵

^{1,2,3,4}Department of Electronics and Electrical Engineering, NHITM, Thane, Maharashtra

⁵ Professor, Dept. Electrical Engineering, New Horizon Institute of Technology, Maharashtra, India

Abstract - The main aim of this project is to style a totally PLC-controlled automobile parking system with less human interference. With the rising population in today's world, time has become most significant and to reduce the time taken by trivial activities like finding an area to park during a busy place and avoid tie up. today we tend to area unit seeing that generally accidents occur in parking things by cars going at high speed or caused by pissed off drivers unable to search out a parking lot for an extended amount of your time. In our project we tend to propose a wise and automatic automobile parking model that may facilitate the user in booking their parking areas beforehand and also the vehicle are ready to park mechanically once within the automobile parking space. The distinction between our project of PLC-controlled automobile parking systems is we tend to hope to reduce human interaction the maximum amount as doable and build each the vehicle and also the park fitted with sensors that may facilitate US execute a secure and economical method of parking. Hence, we tend to aim to produce a totally safe and automatic expertise that's strong and may be enforced in real time and hopefully be enforced because the general norm for parking systems within the future.

Key Words: Dc Motor, Programmable logic controller, Sensors, Relays, Multi floor, Automated.

1. INTRODUCTION

Automated automotive parking could be a technique wherever the system mechanically parks and retrieves cars that usually use a carry mechanism. the bottom space and therefore the capability of the garage will be used additional expeditiously by parking cars during this manner. The intention is to compact additional cars within the same house, scale back the house required to park identical variety of automotives or permit car parking wherever antecedently there would are no space. For electrical vehicles there'll charging facilities wherever the voltage of the automotive are going to be checked and if the battery is absolutely charged there'll be a sign within the unit.

In the Urban Cities the population is bit by bit increasing so is that the use of vehicles. This ends up in increase of parking problems in most thronged places of cities like

malls, market areas, offices etc. The advantages of automatic automobile parking area unit economical usage of areas, decreasing the land area and increasing the quantity of place vehicles, saving time by taking and delivering automobile in an exceedingly few seconds, providing security and safety for the automobile from stealing and damages whereas parking. As for the electrical cars, charging stations aren't nonetheless unremarkably accessible in our country, thus providing a Charging Station at the car parking zone provides the electrical automobile users less difficult accessibility. during this project our main goal is to develop a paradigm of an automatic parking system and charging unit that is capable of parking and retrieving the vehicle. we are going to style the automation method of associate degree automatic parking system and a charging station wherever the total method will get controlled through a Programmable logic unit.

2. DESCRIPTION OF SYSTEM

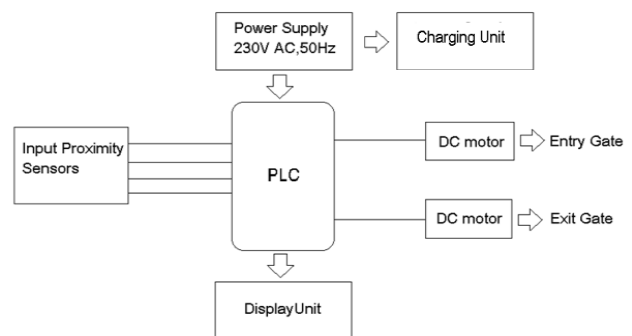

Fig -1 Block Diagram of PLC

2.1 Programmable Logic Controller (PLC)

A PLC may be a laptop specially designed to control faithfully below harsh industrial environments – like extreme temperatures, wet, dry, and/or soiled conditions. PLCs square measure wont to change industrial processes like a producing plant's line, AN beneficiation plant, or a effluent treatment plant. PLCs share several options of the private laptop you've got reception. They each have an influence offer, a computer hardware (Central process Unit), inputs and outputs (I/O), memory, and operative package (although it's a distinct operative software).



Fig -2 PLC MM3030-4

The biggest variations square measure that a PLC will perform distinct and continuous functions that a computer cannot do, and a PLC is far higher suited to rough industrial environments. A PLC are often thought of as a 'ruggedized' computer that manages the mechanical device processes of Associate in Nursing industrial atmosphere. PLCs play a vital role within the field of automation, forming a part of a bigger SCADA system.

A PLC are often programmed consistent with the operational demand of the method. within the producing business, there'll be a desire for reprogramming because of the amendment within the nature of production. to beat this problem, PLC-based management systems were introduced. We'll initial discuss PLC basics before viewing varied applications of PLCs.

2.2 Proximity sensor

Proximity sensors are wont to sight the presence of any object while not the necessity for any physical contact. electromagnetic wave is emitted and checks for the changes within the field of the thing and therefore the signal. Wilfried Gehl, music director Pepperl and Ludwig Emil Klaus Julius Fuchs unreal the primary proximity device. These are utilized in parking heaps, mobile phones, conveyor systems, and lots of alternative places. The three types of



Fig -3 Proximity Sensor

The 3 varieties of proximity sensors are magnetic kind, capacitance kind and high-frequency oscillation kind sensors. The principle is predicated on the coil associated generator to make an magnetic attraction field within the sensing surface's surroundings.

2.3 DC Motor

A DC motor is associate electrical machine that converts current into energy. during a DC motor, the input current is that the DC that is reworked into the mechanical rotation.



Fig -4 Dc Motor

A DC motor is any of a category of rotary electrical motors that converts electrical energy (DC) current into energy. the foremost common varieties believe the forces created by magnetic fields. Nearly all kinds of DC motors have some internal mechanism, either mechanical device or electronic, to sporadically amendment the direction of current partially of the motor.

DC motors were the primary kind of motor wide used, as they might be power-driven from existing direct-current lighting power distribution systems. A DC motor's speed is controlled over a large vary, victimization either a variable provide voltage or by dynamic the strength of current in its field windings. tiny DC motors are employed in tools, toys, and appliances. The universal motor will care for DC however could be a light-weight brushed motor used for transportable power tools and appliances. Larger DC motors are presently employed in propulsion of electrical vehicles, elevators and hoists, and in drives for steel rolling mills. the appearance of power natural philosophy has created replacement of DC motors with AC motors doable in several applications.

3. Result

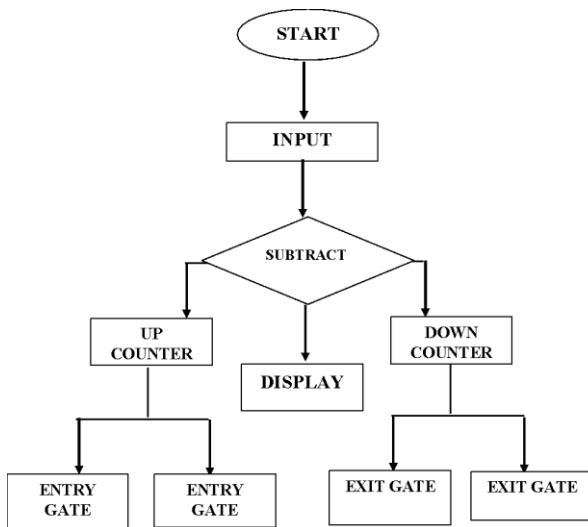
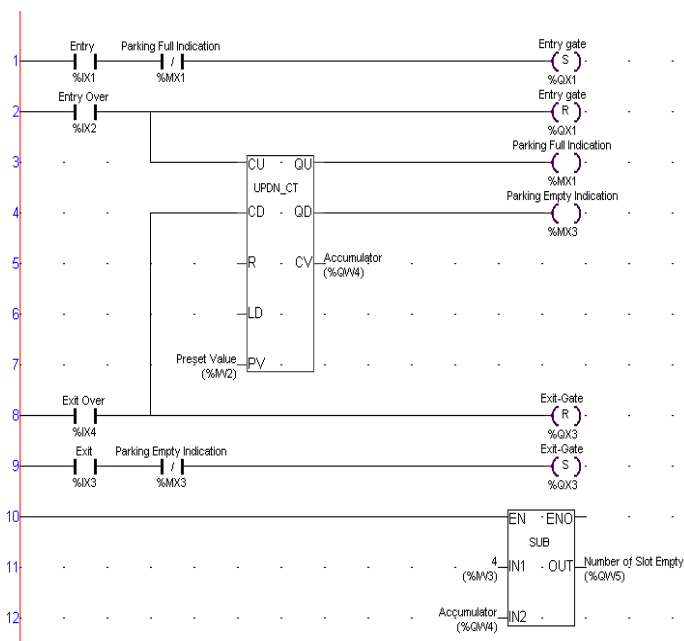

Fig -5 Flowchart of Automatic Car parking system

3.1. Ladder Diagram

Due to jammed space we have a tendency to face voluminous issues of car parking at basement or underground at mall, hotels, complicated etc. this can be happening thanks to contradiction between the apace growing variety of vehicles and restricted parking areas in malls, look and sophisticated in cities ends up in the development of “difficult parking and disorderly parking”. Current parking downside has serious impacts on people’s quality of life and therefore the running of roads.



By simple automation we can reduce the car parking problem in the basement or underground in shopping malls, hotels, complex etc. The Entry/Exit at the basement is a single lane passage and it needs traffic lights to control cars. Here we consider two lights indication for cars control. First Output indication prohibit cars entering or leaving while second output indication lights allow cars entering and leaving. When car enters at the passage from the entry of the ground floor, both the indication will be ON. Other car entering and leaving is prohibited during the process till the car passes through the single passage. When passage is clear both indication will be ON and allow other cars entering from the ground floor or basement. Initially we will keep first indication ON and second indication OFF.

4. CONCLUSIONS

This project is managing to successfully develop an Automatic car parking system and charging station for electric vehicles. Firstly, when a particular car will be placed at the parking point the doors will open and as the car enters the given mark the sensors help to get aligned properly .The charging unit will be situated beside the parking mark and same follows to the other parking marks too. The main advantages of this system are efficient usage of spaces, decreasing the land space and increasing the number of parked vehicles, saving time by taking and delivering car in few seconds, providing security and safety for the car from theft and damages while parking.

REFERENCES

- [1] Shishir Mazumder , Papu Moni Saikia, "International Journal of New Technologies in Science and Engineering", Vol. 5, Issue. 3, 2018, ISSN 2349-078
- [2] IJSRD - International Journal for Scientific Research & Development| Vol. 7, Issue 04, 2019 | ISSN (online): 2321-0613
- [3] International Research Journal of Engineering and Technology (IRJET) e-ISSN: 2395-0056 Volume: 05 Issue: 03 | Mar-2018 www.irjet.net p-ISSN: 2395-0072 "