

GESTURE CONTROL FORKLIFT

Harshad Patil ¹, Vaibhav Chavan ², Omkar Gaikwad ³, Nikhil Pathak ⁴, Ganesh Mhatre ⁵

^{1,2,3,4} UG STUDENT Department Of Mechatronics NHITM,Thane.

⁵ Assistant Professor, NHITM,Thane.

Abstract :- In this paper we introduce hand gesture control based prototype of the forklift. Conventionally , To move any object required the human efforts or any machine which is operated by the human with the buttons controls machine which is highly risky . But nowadays technology is moved faster with the help of internet. We can control any type of machine with internet . So we try make the device which is work on the internet of things .The device is made up of various sensor . This device is control with the help of hand gesture . We use accelerometer to detect the hand gestures . Using hand gesture user can moved the device in forwards , backwards , turns left , turns right .This is made for the loading and unloading the goods .

I.INTRODUCTION;-

Recently technology is advanced . There are many changes comes in the technology . Use of internet of things reduces the human intervention with machine.

We try to execute a interface which allows user to navigate a device Gesture control is the easy way to control vehicle or this Systems. To navigates Forklift we used to different hand gesture

There are many hand gesture recognition system they are Following is (1) Internet based trajectory recognition system (2) vision based trajectory system.

We make the system with Arduinos based the Gesture Control Forklift an interface proposed by us as detailed in section(III, IV) .The working of the system is given section (V ,VI).

II.OBJECTIVE :-

1. Speed is important any devices . Due to use of sensor which are based on IoT make the device faster. The response time this sensor is very accurate and quick .

2.Sensor can sense little minute vibration , every movements of the devices . So they great output . Due to good sensing capability they work properly .

3.There is less number of components use to make this devise so the cost manufacturing is less .

4. To make the design of this vehicle in such way that they can used for various purposes . by changing some structures it can be used for various work.

III.HARDWARE OF SYSTEM :-

1.ACCELEROMETER :-

It is an electro mechanical sensor. It is designed to measure either static or dynamic acceleration . It converts. mechanical energy into an electrical energy . The multi axis accelerometer Can detect both the magnitude and the direction of acceleration.

It is used to measure vibration on cars, machines, buildings. It i also used t to recordings of High frequency of bi-axial or Tri- axial acceleration

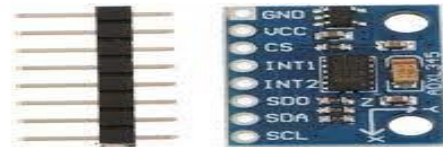

Image :- 1.Accelerometer

2.ARDUINO NANO

Arduino nano is a small complete breadboard based on the ATmegas 328 The arduino nano is the most used and documented board of the whole Arduino family The Atmega 328 also Feature 1kb of EEPROM. Input voltage have 7-12 V. It have 8 analog pins

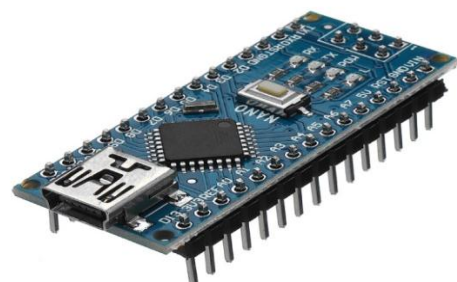

Image :-2 Arduino nano

4. RF MODULE :-

RF module provide design solution for IoT,M2M and smart application Projects. It is small electronic device. That is used to transmit or receive audio signal between two devices. It is often desirable to communicate with another device wirelessly.

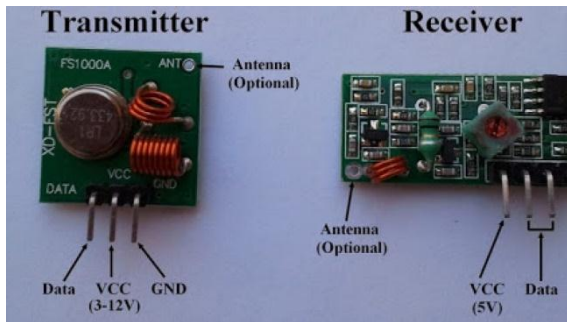

Image :-3 RF module

5.MOTOR DRIVER :-

motor driver, module used for driving DC and stepper motors. we used L298 motor driver. It is high power motor driver motor driver module.

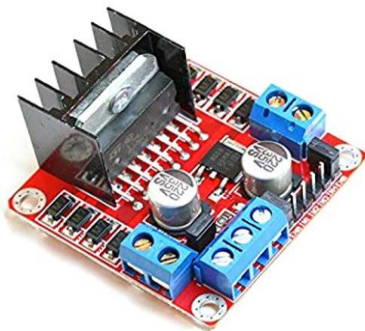

Image :- 5 Motor driver

6.HT 12 D :-

The HT 12 DC IC is a cmos series 12 bit RF decoder. Mostly it is used remote Control Application have this technology's .



Image :- 6 HT12D

7. HT 12 E :-

The HT 12 E IC is always come with its. Pair with HT12D. These together form an Encoder and Decoder pair.



Image :- 7 HT12E

SOFTWARE USE

1) Audino software :-

We use open source Arduino Software (IDE) make it easy to write code and upload it into the system.

2) Protius software:-

We use this software to design our PCB board. Software made design quick and easy.

3) Diptrace software:-

We use this Software to design Schematic circuit diagram.

IV.CIRCUIT DIAGRAM :

1.TRANSMITTER CIRCUIT

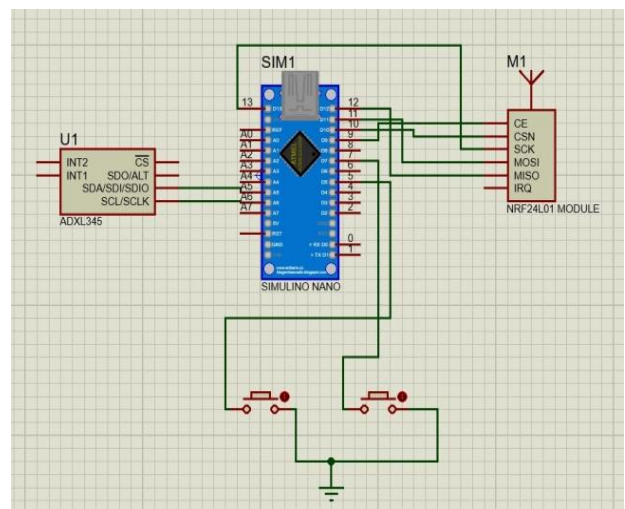

Figure :1 Transmitter circuit diagram

In the transmitter circuit Accelerometer ADXL 345 is used detect motion as gesture the accelerometer senses the motion and sends to microcontroller .

Then microcontroller sends the the signal to the HT12E Encoder. The HT12E sends the output of Encoder to RF Transmitter. The data sent by microcontroller is receive and is transmitted through RF Transmitter. This data will by receive RF Receiver.

2.RECEIVER CIRCUIT :

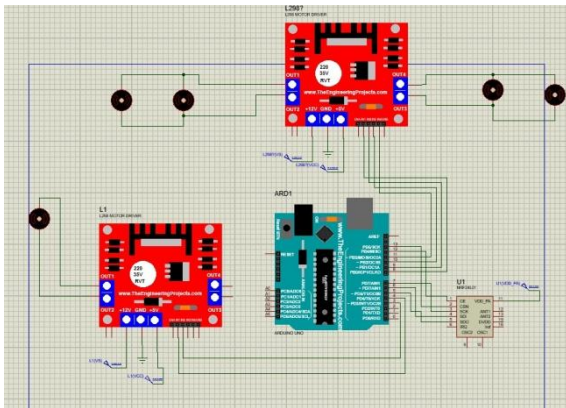

Figure :2 Receiver circuit diagram

The transmitted data sent by RF transmitter is received by RF receiver. This signal is decoded by HT 12D Decoder. The decoded signal is sent to motor driver the motor driver give access to the motor and work according to it.

V.FLOW CHART / DIAGRAM

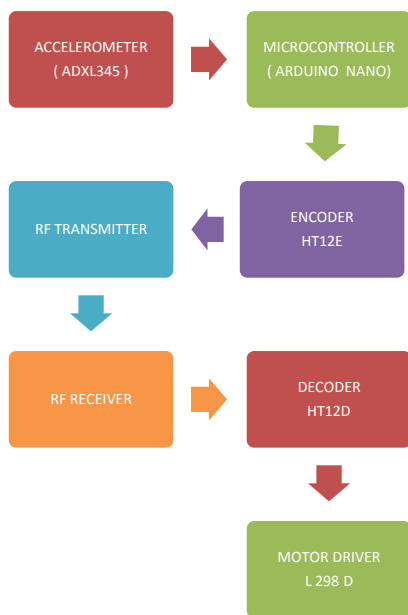

Figure 3:- flow chart / diagram of proposed system

VI.WORKING MODEL:-

When user make the gesture like they move their hand or turn it that motion of their hand is detect by accelerometer sensor.

Accelerometer sensor is to detect and sends that signal to arduino nano receive it and work on it .

Arduino sends the signal to encoder HT12D . Encoder sends the encoded signal to RF transmitter .

Transmitted signal is received by the RF receiver and send to decoder . decoder decoded that signal sends to motor driver.

Motor driver drives the motor according generated signal.

In this system we use two buttons for lifting up or down word of forklift . In the proposed system one button use for lifting upwards of forks and another one is use for down word motion of the forks.

VII.CONCLUSION :-

In this paper , gesture control forklifts has been design and construct it. This device is fully automatic moves according to hand gestures .This is the prototype device therefore it works in the range of 0-100 Meter area. At the end of result expected efficiency of the device is achieved. This device can upgrade to a construct wheelchair too the physically challenged people’s . or to construct the gaming car or fighter robot’s .

VIII.REFERENCE :-

1. www.ijtee.org in
2. www.ijsdr.org
3. Hand Gesture Recognition Based Controlled Vehicle, International Journal on Emerging Technologies (Special Issue NCETST-2017) 8(1): 94-97(2017)
- www.researchtrend.net
4. www.electronicwings.com
5. www.electronicshub.com
6. <https://lastminuteengineers.com/>