

DESIGN AND ANALYSIS OF THERMAL COOLING SYSTEM FOR PASSENGER COMPARTMENT OF AUTOMOTIVE VEHICLE

MEET MUKESHBHAI PATEL¹, PANKIT KAMESHBHAI SHAH², PRIYANK SANJIV VOHRA³, MIHIR RAJUBHAI PATEL⁴, RANJAN KUMAR⁵, PROF. MADHUSUDAN BAROT⁶

^{1,2,3,4,5} UG Student of Automobile Engineering, Indus University, Gujarat, India

⁶ Assistant Professor of Automobile Engineering, Indus University, Gujarat, India

Abstract – This research work describes the prototype and implementation of automotive cooling system. During the summer and winter seasons, the temperature inside a car parked outdoors can be very high or low, which can be offensive to drivers and passengers. Therefore, there is a need for a device that keeps the inside of the car at a comfortable temperature in parking lots and driveways. The purpose of this research was to build a lightweight and compact car cooler. The car's air conditioning system allows the driver to maintain a reasonable temperature while sitting at home or in the parking lot. The designed system can fit in a car hut.

Key Words: Air cooling, Heating, Car Cooling, Car Heating, Cooling fan.

1. INTRODUCTION

While summer time warmth is in dangerous, and when we return to the car that has left open in direct daylight, the cabin is best one oven. on this mission, we've got advanced a manner to quickly cold your automobile or avoid in summer season. absolutely everyone is familiar with the moment when it again to their vehicle on a warm summer time day, and they open the door to welcome matters like the freshest region on this planet-your automobile inside cabin.

Most of the people are currently using a vehicle, and at the same time as riding, the auto may additionally ought to park outdoors uncovered to direct sunlight. if you park your car in the daylight for a long term, the air within the car becomes very hot. The temperature in the car can easily rise to 55 ° C. Even on a fairly cloudy day, the temperature inside the car can effortlessly reach 45 ° C. it's difficult to get in a vehicle that has been uncovered to the sun for several hours. The high temperature within the car causes absolute soreness to the driving force for the first 10 minutes.

In current years, many researchers at the thermal comfort of vehicles were suggested. On a clear day, the comfort of the auto relies upon closely on the heat radiation change between the automobile and its environment, and the inner radiation within the vehicle. Radiation is arguably the maximum instant phenomenon of power transfer. To be satisfied, it is enough to bear in mind the instant sensations and comfort you sense while you switch on a shaded street after a long force on a sunny day.

The fan gadget installed in the cabin box detects the temperature with a temperature probe constant to the cabin that detects the temperature and sends a sign to the cooling machine. The fan machine sends a sign to the controller that knows the temperature that detected the temperature. increasingly more with Bluetooth wireless generation, the warmth of the automobile evaporates and the car is cooled to 2-3°C. the percentage of warmth dissipated in the four-wheeler. may be decided from preliminary warmness switch analysis. you can also consciousness on a particular gasoline kind. warmness transfer analysis consists of convection and radiation from the glass to the inside and outside of the car. approximately eighty% of the temperature in the automobile rises within the first 30 minutes.

It then passes thru a cleanser, scrubber, or other filter out that reduces the amount of fuel. whilst the ambient temperature changed into 22.2 ° C to 35.6 ° C, the average temperature inside the automobile multiplied by using 44 ° C. On a clear day, the temperature upward thrust of the automobile was simply sizeable despite the fact that the ambient temperature was not so excessive. The engine can't offer the surest operating temperature; consequently, it ends in the heavy-obligation operation at the engine and increases the gasoline intake.

2. Literature Review

P. Danca, A. Vartis, and A. Dožanu ^[1] developed a methodology for monitoring the internal temperature of vehicles parked in the sun. It can be seen that the temperature rises of the vehicle when parked on a sunny day is a significant problem that causes inconvenience to passengers.

M. Simion, L. Socaciu, and P. Unguresan ^[2] studied Factors that Influence the Thermal Comfort inside vehicle. it states that the ventilator inhales contemporary air from outside into the within cabin of a vehicle and exhales hot air to the surface. On a sunny day, solar power is wont to run the ventilator, and to charge the battery at the same time. throughout a cloudy day, the ventilator is driven by the battery.

M. F. Basar, M. Musa, M. Y. Faizal, and N. H. a Razik ^[3] has found the choice means in Reducing automotive Cabin

Temperature victimization transportable automotive Cooling System (Car-Cool). the most objective of the analysis is to propose a cooling system that ready to management and maintain temperature within the automotive at the vary of twenty-five to thirty once place underneath very popular condition. The results of testing show that the vehicle's owner whom victimization this product capable to take care of the galley temperature approaching temperature.

R. Saidur, H. H. Masjuki, and M. Hasanuzzaman ^[4] investigate the Performance of AN Improved star automotive Ventilator. This investigation tried that, the improved star automotive ventilator will offer a comfort level on top of the present star automotive ventilator. Improved ventilator provided a minimum of Martinmas reduced temperature within a automotive compared to the present ventilator. The flow of improved ventilator was five.5 times on top of existing ventilator. If the flow of star automotive ventilator is enlarged, the higher result may be obtained for the soak temperature. it'll offer larger comfort for passengers on their initial entrance to the vehicle, keeping the inside cooler.

D. Costa and At. all ^[5] will conduct an analysis of the associated title of children left unattended in secular cars in Brazil. Regarding the amount from 2006 to 2015, we tend to gather information from the news on thirty-one cases and twenty-one deaths. The cases largely involved a caregiver, particularly a parent, who forgot the child (71%), but the cases also included the child deliberately left in the vehicle (23%) or access to four wheels (3%). Children served are more often forgotten in fatal cases (86%), mainly due to day care, then in non-fatal accidents where circumstances were more evenly distributed between forgetting (40%) and deliberate abandonment (50%).

Danish EPA ^[6] has done the danger assessment of risky substances within the indoor setting of cars. the goal of this project is to solicit a summary of whether or not the amount of VOCs in new / new cars will cause a health risk. The project is focusing alone on the emission from the inside elements of the cabin, because the indoor air quality laid low with external contaminants like ventilation air containing exhaust residues of fuel and substances gaseous from the equipment of the automobile, aren't coated by the project. the inside elements of the automobile cabin encompass many manmade materials, which can emit completely different chemical compounds. The contribution from every material to the concentration within the car's indoor climate depends on the area of the fabric, and whether or not the surface is roofed by different materials.

K. Omar ^[7] found the detection of the composition of aromatic hydrocarbon vapors formed inside the passenger compartment of the car. the results show that their squares measure completely different compositions of gas within the passenger compartment of the cars. In addition to the gas (Z)

-1- (Ethoxycarbonyl-1-Fluoro-2- (Methoxycarbonyl) -1, 3- Butadiene, which is found inside the cabins of cars, there are alternative gases of square measurement such as- (3 -Oxo-3H- Benzo [F] Chromen-2-Yl) -2, 4 (1H, 3H) - Quinoline Dione, Ethane-D6, Ethylene-D4, Heptacosafuoro-Tributylamine, Nonanal, Decanal, caracin capric acid, 11-Dodecen -1-Al, benzenethanamine, 3-fluoro-a, 5-dihydroxy-N-methyl-, 2-base propionic, organic compound a-methyl-a-oxo-ethyl, silane methyl-, hexadecenoic acid.

S. C. Vishweshwara, J. Marhoon and A. L. Dhali ^[8] established the study on the mitigation and excessive temperatures of the car interior in Muscat and Oman. It shows that the international isolation of the main stars of Muscat and Oman generally causes very high temperatures in the vicinity, especially during the summer season. During the summer, if cars are directly exposed to the sun, the interior of the car can undergo a form of atmospheric phenomenon which can cause the interior temperature to rise and cause car problems such as color fading and wear of the seat covers, and even cause injuries to various components of the cabin. The extreme temperature that prevails inside the vehicle in daylight is definitely out of reach of the occupants once they arrive they have to drive.

M. A. Jasni ^[9] had done Associate in Nursing experimental Comparison Study of the Passive ways in Reducing automotive Cabin Interior Temperature. the aim of this experimental study is to see the foremost technically possible passive technique in reducing the automotive interior temperature. 3 ways were through an experiment studied; mistreatment sunshades, ventilators and window tints. A 1.5 national sedan automotive was utilized in this study wherever it had been exposed to direct daylight for an amount of five hours for four totally different cases. The temperatures measured by thermocouples strategically set at intervals the automotive were obtained and analysed. it's discovered that the most temperature occurred at the dashboard for all cases. The usage of ventilators is found to scale back the typical most temperature for the close air within the automotive by the maximum amount as 3.3o C.

3. Components Specification

3.1 ARDUINO UNO

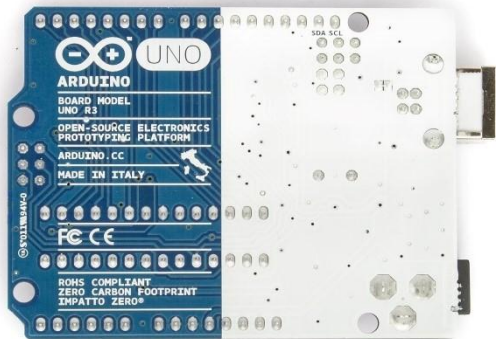

Fig -1: Arduino Uno R3 Back



Fig -2: Arduino Uno R3 Front

Overview

The Arduino UNO is a microcomputer which is based on the ATMEGA328 microcontroller. It contains 14 digital input/output pins, 6 analogue inputs, a 16 MHz ceramic resonator, a USB connector, a power source, a 3ICSP header, and a reset button. contains all of the components required to run a microcontroller. The FTDI USB TOSERIAL controller chip is missing from the UNO, as it is on all previous cards. The Atmega16U2, on the other hand, is configured as a USB to serial converter.

1.0 pin array: Added AREF pin, near SDA pin and SCL pin, and IOREF near 2 other new pins, RESET pin. This allows the screen to be adjusted to the voltage supplied by the board. In the future, the shield will be compatible with both boards that use AVRs that operate at 5V and Arduino Dues that operate at 3.3V. The second is an unconnected pin that is reserved for future use.

- Stronger RESET circuit.
- Atmega 16U2 replace the 8U2.

"Uno" manner one in Italian and became named to signify the subsequent Arduino 1.0 release. Uno and model 1.0 could be the reference model of the evolving Arduino. Uno is the modern product at the USB Arduino board and is the reference version for the Arduino platform. See the Arduino Board Index for a contrast with preceding versions.

Summary

Microcontroller	ATmega328
Operating Voltage	5V
Input Voltage (recommended)	7-12V
Input Voltage (limits)	6-20V
Digital I/O Pins	14 (of which 6 provide PWM output)
Analog Input Pins	6
DC Current per I/O Pin	40 Ma
DC Current for 3.3V Pin	50 mA
Flash Memory	32 KB (ATmega328) of which 0.5 KB used by bootloader
SRAM	2 KB (ATmega328)
EEPROM	1 KB (ATmega328)
Clock Speed	16 MHz

Power

By using USB or external power supply, the Arduino Uno can be powered. The power supply will be selected automatically. The AC to DC adapter (wall outlet) or battery can provide external (non-USB) power. You can connect the adapter by plugging the 2.1mm Center Plus plug into the power jack on the board. The battery cable can be plugged into the Gnd and Vin headers of the POWER connector. The board can be powered from an external 6–20-volt power source. Below 7V, the 5V pin supplies less than 5 volts and can destabilize the board. If a voltage above 12V is used, the voltage regulator may overheat and destroy the board. 7 to 12 is the optimum range.

- VIN. Input voltage to the Arduino board whilst the usage of an outside electricity deliver (rather than five volts from a USB port or different regulated electricity deliver). Power may be provided thru this pin. If electricity is furnished thru the electricity jack, get admission to via this pin.
- 5V. The board regulator offers a managed 5V to this pin. A DC electricity jack (7-12V), a USB connector (5V), or the board's VIN pin can all be used to electricity the board (7-12V). Bypassing the regulator and powering the board at once from the 5V or 3.3V pins, can harm the board. We strongly suggest you to withstand this.
- 3V3. A 3.3-volt deliver generated via way of means of the on-board regulator.
- GND. Ground pins.

Memory

ATmega328 is 32KB (0.5 KB is used for the boot loader). It also has 2KB of SRAM and 1KB of EEPROM (which can be read and written using the EEPROM library).

3.2 HC-05 Bluetooth to Serial Port Module

Overview



Fig -3: HC-05 Bluetooth to Serial Port Module

The HC-05 module is a easy Bluetooth SPP (Serial Port Protocol) module that lets in for the development of a obvious wi-fi serial connection. Bluetooth V2.0+EDR (Enhanced Data Rate) 3Mbps Modulation serial port Bluetooth module. It has a CSR Blue center 04-External unmarried chip Bluetooth device with CMOS and AFH technology (Adaptive Frequency Hopping Feature). It has a modest footprint of 12.7mmx27mm. I wish it'll make your complete design/improvement manner easier.

Specifications

Hardware features

- Typical -80dBm sensitivity
- Up to +4dBm RF transmit power
- Low Power 1.8V Operation ,1.8 to 3.6V I/O
- PIO control
- UART interface with programmable baud rate
- With integrated antenna
- With edge connector

Software features

- Default Data bits: 8. 1st stop bit Baud rate: 38400 There is no parity in this. It has data control supported, baud rate: 9600, 19200, 38400, 57600, 115200, 230400, 460800.
- If PIO0 has a rising pulse, the device will be stopped.
- PIO1 status instruction port (low-disconnected, high-connected).
- Red and blue leds can be linked to PIO10 and PIO11 individually. When the master and slave are coupled, the red and blue leds blink every 2 seconds, whereas when they are disconnected, only the blue led blinks every 2 seconds.

- By default, auto-connect with the most recently powered-on device.
- Allow the pairing device to connect without a hitch.
- When auto-pairing, the default PINCODE is "0000."
- If you are disconnected because you have moved out of range of your connection, it will reconnect in 30 minutes.

3.3 L298N Dual H-Bridge Motor Driver

The L298 Dual H-Bridge Motor Driver Integrated Circuit is the bottom of this twin bidirectional motor driver. The circuit will assist you to control cars in each guideline with comfort and independence. It is properly desirable for robot packages and can be incorporated to a microcontroller simply with some manipulate strains in keeping with motor. Simple guide switches, TTL good judgment gates, relays, and different digital gadgets can all be connected to it. This board consists of energy LED signals, a +5V regulator on board, and shield diodes.

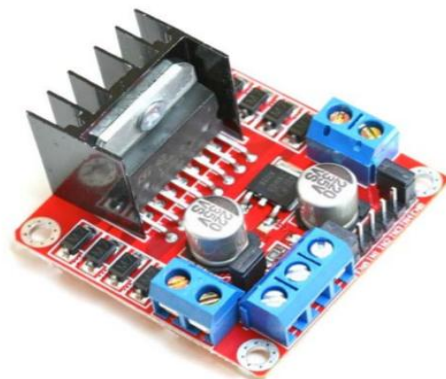

Fig -4 SKU: MDU-1049

Brief Data:

- Input Voltage: 3.2V~40Vdc. Brief Data:
- Driver: L298N Dual H Bridge DC Motor Driver
- Power Supply: DC 5 V - 35 V
- Peak current: 2 Amp
- Operating current range: 0 ~ 36mA
- Control signal input voltage range:
- Low: $-0.3V \leq V_{in} \leq 1.5V$.
- High: $2.3V \leq V_{in} \leq V_{ss}$.
- Enable signal input voltage range:
- Low: $-0.3 \leq V_{in} \leq 1.5V$ (control signal is invalid).
- High: $2.3V \leq V_{in} \leq V_{ss}$ (control signal active).
- Maximum power consumption: 20W (when the temperature $T = 75^\circ\text{C}$).
- Storage temperature: $-25^\circ\text{C} \sim +130^\circ\text{C}$
- On-board +5V regulated Output supply (supply to controller board i.e., Arduino).
- Size: 3.4cm x 4.3cm x 2.7cm

Schematic Diagram:

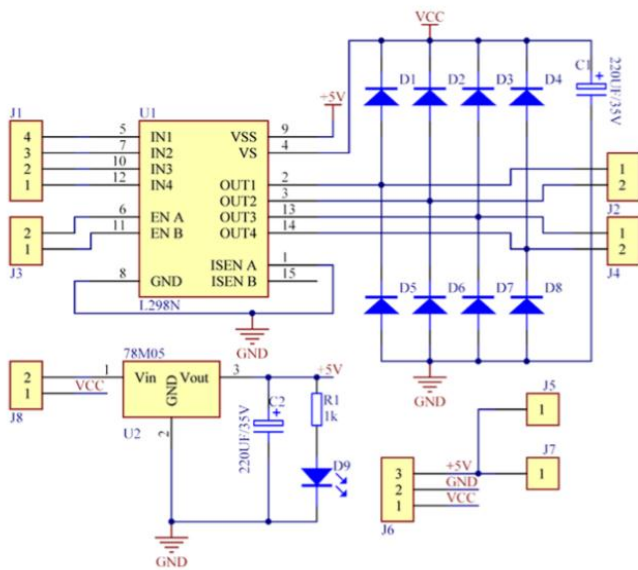

Fig - 5: Schematic Diagram

FEATURES: DC Fan
24V 6020
Brushless DC Cooling Fan

SPECIFICATIONS:

- Size: 60mm (L) x 60mm (W) x 20mm (H)
- Rated Voltage: 24V
- Rated Current: 0.15A
- Rated Power: 2W
- Rated Speed: 4000RPM
- Noise Level: 28dB(A)
- Connector: 2pin/2wire

3.5 CONTAINER BOX

- Here we have used the 25ltr plastic container box for the project
- The size of the box is 26x45x34 cm.

Board Dimension & Pins Function:

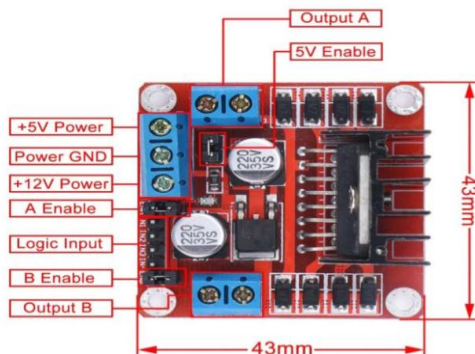

Fig -6: Board Dimension

3.4 FAN



Fig -7: Fan

Ultra-quiet Low-speed brushless DC fan.
Size: 60mm (L) x 60mm (W) x 20mm (H).
Housing Material: High Quality Plastic Housing .24V, 0.15A



Fig -8 CONTAINER BOX

3.6 Waterproof DS18B20 Digital Temperature Sensor



Fig -9 Temperature Sensor

The DS18B20 Arduino Temperature sensor has been waterproofed in this version. When you need to measure something from afar or in damp conditions, this tool comes in handy. While the sensor can withstand temperatures up to 125°F, the cable is PVC-coated, thus we recommend keeping it around 100°F. Even over vast distances, there is no signal deterioration because they are digital! The DS18B20 uses a 1-Wire interface to provide 9 to 12-bit (adjustable) temperature readings, requiring only one wire (and ground) from a central CPU. 3.0-5.5V systems are compatible. Multiple DS18B20s can exist on the same 1-Wire bus since each DS18B20 has a unique silicon serial number. This enables temperature sensors to be placed in a variety of locations. HVAC environmental controls, measuring temperatures inside buildings, equipment or machinery, and process monitoring and control are among applications where this functionality comes in handy.

Specification

- Temperature range: -55 to 125° C
- 1-Wire interface
- only one digital pin for communication
- 64-bit ID burned to chip
- Temperature-restriction alarm system
- Query time: less than 750ms
- 3 wires interface: red wire (VCC), Black wire (GND) Yellow wire (DATA)
- Stainless steel tube
- Tube diameter: 6mm
- Cable diameter: 4mm
- Length: 90cm

2.7 Battery



Fig -10: Battery

Here, we have used 12-volt 1.2 Ah rechargeable sealed lead acid battery. The length of battery is 3.82”, width is 1.69” and the height is 2.01”.

4. Calculation

CALCULATION OF THE REQUIRED DATA AND TIME

Battery charging time

Battery rating = 2 amp / hour

Required = 1.75 amp / hour

Battery life = 1.14 hour /all fan

1 fan

N = 2000 rpm

I = 2.50 mA current

Voltage = 12 volt

$P (in) = V \times I$

$$= 12 \times 250 \div 0.001$$

$$= 3 \text{ watts/Fan}$$

$P (out) = 2\pi NT \div 60000$

$$= (2 \times 3.14 \times 2000 \times 1.25) \div 6000$$

$$= 2.61 \text{ watts}$$

Total power consumption,

$$= P (out) \times n (\text{no of fan})$$

$$= 2.61 \times 8$$

$$P(\text{total}) = 20.88 \text{ watts}$$

$$P = V \times I$$

$$I = P \div V = 20.88 \div 12 = 1.75 \text{ Amp.}$$

Flow per fan,

Q = 25 liters/min (LPM)

$$= 25 \times 10^{-3} \text{ m}^3 / \text{min}$$

Total volume of container = 25 liters

Flow all fan,

Q (total) = 25×8 = 200 liters / min

$$= 200 \times 10^{-3} \text{ m}^3 / \text{min}$$

Total time required for cooling,

$$= 1 \text{ min} / 8$$

$$= 25 \text{ sec}$$

5. Conclusion

In present scenario, due to abnormal atmospheric condition, harmful gas is generated. The present thermal cooling system has a capacity to reduce hazardous gases and create comfortable condition inside the car.

In order to improve the fuel efficiency of the vehicle, it is important to reduce the air conditioning load of the vehicle. If the heat load in the passenger compartment can be reduced, the power consumption of the air conditioning compressor can also be reduced.

A potential way to reduce a car's fuel consumption is to lower the car's climate temperature. Minimizing the heat build-up in the cabin using a fan has been reported as an efficient way to lower the soak temperature. The energy absorbed by the glass determines the temperature of the glass and thus the direction of heat flow.

References

- [1] P. Danca, A. Vartires, and A. Dogeanu, "An Overview of Current Methods for Thermal Comfort Assessment in Vehicle Cabin," *Energy Procedia*, vol. 85, pp. 162–169, 2016.
- [2] M. Simion, L. Socaciu, and P. Unguresan, "Factors which Influence the Thermal Comfort Inside of Vehicles," in *Energy Procedia*, 2016, vol. 85.
- [3] M. F. Basar, M. Musa, M. Y. Faizal, and N. H. a Razik, "Alternative Way in Reducing Car Cabin Temperature Using Portable Car Cooling System (Car-Cool)," *International Journal of Innovative Technology and Exploring Engineering*, vol. 3, no. 3, pp. 140–143, 2013.
- [4] R. Saidur, H. H. Masjuki, and M. Hasanuzzaman, "Performance of An Improved Solar Car Ventilator," *International Journal of Mechanical and Materials Engineering*, vol. 4, no. 1, pp. 24–34, 2009.
- [5] D. Costa and A. Grundstein, "An analysis of children left unattended in parked motor vehicles in Brazil," *International Journal of Environmental Research and Public Health*, vol. 13, no. 7, 2016.
- [6] P. Ferrara et al., "Children left unattended in parked vehicles: A focus on recent Italian cases and a review of literature," *Italian Journal of Pediatrics*, vol. 39, no. 1, p. 1, 2013.
- [7] Danish EPA, Risk assessment of hazardous substances in the indoor environment of cars - a pilot study, no. 154. DK-5000 Odense C: The Danish Environmental Protection Agency Editor, 2017.
- [8] K. Omar, "Detection of the vapor benzene composition formed inside the car cabin," *Chemical Physics*, vol. 36, no. 2011, pp. 3501–3503, 2011.
- [9] N. M. Barnes, T. Ng, K. K. Ma, and K. M. Lai, "In-cabin air quality during driving and engine idling in air-conditioned private vehicles in Hong Kong," *International Journal of Physics: Conference Series*
- [10] S. C. Vishweshwara, J. Marhoon, and A. L. Dhali, "Study of Excessive Cabin Temperatures of the Car Parked in Oman and its Mitigation," *International Journal of Multidisciplinary Sciences And Engineering*, vol. 4, no. 9, pp. 18–22, 2013.
- [11] M. A. Jasni and F. M. Nasir, "Experimental Comparison Study of the Passive Methods in Reducing Car Cabin Interior Temperature," 2012, pp. 229–233.
- [12] T. Hendricks and T. Thoensen, "Passive cooling system for a vehicle," US 2005/0061484A1, 2003.
- [13] A. C. Wong, R. P. Feight, J. D. Duffy, and G. S. Hall, "Vehicle interior cooling system," CA2575027C, 2007.