

## CONCRETE-ENCASED CFST BEAM-COLUMN JOINTS: A REVIEW

Ashina Anna Ronni<sup>1</sup>, Jinta John<sup>2</sup>

<sup>1</sup>Student, St. Joseph's College of Engineering and Technology, Palai

<sup>2</sup>Assistant Profosser, St. Joseph's College of Engineering and Technology, Palai

\*\*\*

**Abstract** - Beam- column joints are the most seismically affected element in a framed structure, hence seismic performance of joint is of great importance for overall structural safety. In order to make appropriate design decisions for joints, it is necessary to know how joints behave.

Concrete-encased concrete-filled steel tubular (CFST) beam-column joints consist of CFST inside and reinforced concrete outside. Several investigations have been conducted on joints with steel beams and RC columns and with steel beams and CFST columns. This paper reviews the present state of knowledge of properties and performance of concrete-encased CFST beam-column joints.

**Key Words:** Beam-column joints, CFST, seismic performance.

### 1. INTRODUCTION

Earthquakes are violent tremors in the earth's crust that generate shock waves in all directions from its point of origin which is caused by a sudden release of energy in the earth's crust that causes seismic waves. The intersections of beams and columns at reinforced concrete structures are called beam-column joints. Beam-column joints are the most seismically affected element in a framed structure, hence seismic performance of joint is of great importance for overall structural safety. The connection between beam and column in a frame structure is most likely to sustain damage during a seismic disaster. In order to make necessary design decisions for joints, you need to know how joints behave.

A composite member is a structural member made up of two or more materials having dissimilar properties. [6] As they are made of multiple materials, they exhibit properties of both and have superior properties to the individual ones. One of the most popularly used composite members in the structural engineering industry is steel-concrete composite. As we all know concrete is good in taking compressive load and weak in taking tensile load. Also, steel is strong in tension loading. By combining both, it utilizes concrete's compressive strength and steel's resistance to tension and making it more efficient in construction. Concrete-filled steel tubular structures are one among these types of concrete-steel composite.

Concrete-filled steel tubular (CFST) structures have great structural benefits, including increased strength and resistance to fire attack, high ductility and energy

absorption. In some recent buildings, concrete-encased steel-tube columns (CFST) have been used to connect with reinforced concrete (RC) or steel beams. The concrete-encased concrete-filled steel tubular (CFST) beam-column joint is made up of core CFST and reinforced concrete (RC) outside. As the composite column is more fire-resistant and structurally durable than a typical CFST one due to the outer RC part. Fig 1 shows typical cross section of concrete-encased CFST columns. Concrete-encased CFST beam-column joints are stronger, more ductile, and can carry more weight than ordinary RC beam-column joints due to the performance of their embedded steel tube. Moreover, the composite joints demonstrated favourable seismic behaviour and could be used in earthquake-prone areas. Concrete-encased concrete-filled steel tubular (CFST) beam-column joints consist of CFST inside and reinforced concrete outside. This method has certain advantages over conventional reinforced concrete (RC) columns, such as higher ductility due to the contribution of the CFST, and faster construction speed because the CFST can be constructed first to carry the entire construction load by itself and concrete and reinforcing bars for the outer walls can be poured or installed later.

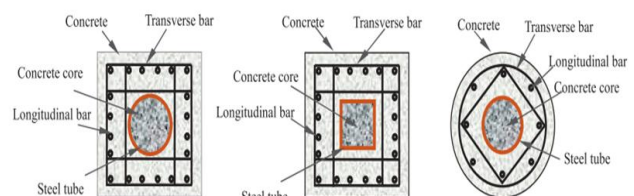

Fig-1: Commonly used cross sections of concrete-encased CFST columns.

### 2. COMPONENT BEHAVIOUR OF CFST

The widespread application of concrete-filled steel tubes in engineering has led to large-diameter steel tube columns being used in the ground floors of high-rise and super high-rise buildings. By decreasing the cross-sectional dimensions of the upper columns as the number of floors increases, the dead weight of the structure will be reduced and engineering costs will be saved. The column connections where the cross-sectional sizes change become the crucial area that affects the seismic performance of the whole structure. Typical sections of steel used for CFST for filling concrete are circular hollow section (CHS), a square hollow section (SHS) or a rectangular hollow section (RHS). It is found that circular cross sections provide the strongest locked up to the core concrete, whereas

square or rectangular cross sections are more likely to cause local buckling. In the meantime, concrete-filled steel tubes with SHS and RHS are still increasingly used in construction due to their ease of beam-to-column connection design, high cross-sectional bending stiffness, and aesthetic value. The use of polygons, elliptical and rounded-ended rectangular shapes for aesthetic purposes is also becoming common now-a-days. Fig 2 shows typical concrete-filled steel tubular cross section.

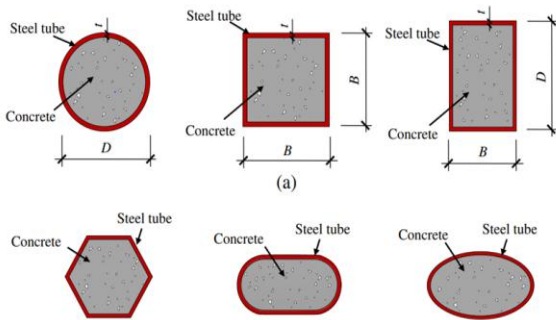

Fig-2: Typical concrete-filled steel tubular cross sections.

It is known that concrete is good in taking compressive load and weak in taking tensile load. Despite structural steel's high tensile strength, its shape may buckle locally under compression. CFST is designed in a way that most important characteristics of both concrete and steel can be taken advantage on the structure. The concrete and the steel tube sustain the axial load coming to the structure together. Concrete confined in steel tube, and the concrete core helps to relieve local buckling of the steel tube. Fig 3 shows the schematic failure modes of hollow steel tube, concrete and CFST columns. The steel tube shows both inward and outward buckling, while the concrete column exhibits shear failure. Only the outward buckling of the concrete-filled steel tube can be observed, and the inner concrete fails in a more ductile manner.

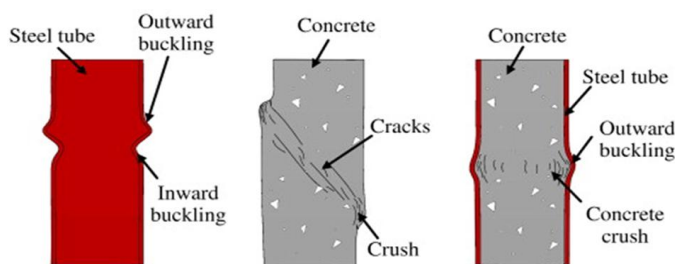

Fig-3: Schematic failure modes of hollow steel tube, concrete and CFST columns.

Apart from conventional CFST other members coming under this CFST family are concrete-filled double skin steel tubes, concrete-encased concrete-filled steel tubes and reinforced and stiffened concrete-filled steel tubes.

### 3. CONNECTIONS CONSIDERED FOR JOINTS

At the time of a seismic disaster damages usually concentrates around the beam-column connection. The combination loading of shear force and bending moment tend to lead to the damage of the connection between beam and column and further to the collapse of structure. Hence, seismic performance of beam-column connection is a critical factor affecting the life of the structure. Different connections considered for joints and their behaviour were also studied by authors and they are follows:

Beam-column connections are mainly divided into internal-diaphragm, through-diaphragm, and external-diaphragm connections. [2] The internal-diaphragm beam-column connections weld the diaphragm inside the column position corresponding to the flange under maintaining the column, the through-diaphragm beam-column connections separate the upper and lower steel tubular columns through the diaphragms connected with the beams and the external-diaphragm beam-column connections connect the beams and columns through the external diaphragm. In case of through-diaphragm beam-column connections, the arrangement of diaphragms guarantees continuity of pressure transfer, but it is difficult to weld the inner diaphragms, and only welding can secure the through-diaphragms to the columns. In case of workability external beam-column connections are highly workable.

Zhang et al. [3] studied the seismic behaviour on the external-diaphragm beam-column connections of central columns and side columns under axial compressive load and cyclic load. The cyclic shear tests of unequal height beam-tube column connections with outer annular stiffeners were carried out by Mou et al. [4], and the experimental results demonstrated that the increase in outer annular stiffener size improved the hysteretic behaviour of the connections. A study by Bai et al. [5] compared the seismic performance of steel beam-columns connected with outer annular stiffeners under unidirectional and bidirectional cyclic loads and proposed the calculation of strength formula for ring stiffeners. When compared with the other two connections, external-diaphragm beam-column connections have better structural performance, including higher bearing capacity, better plastic deformation, and more efficient stress transfer.

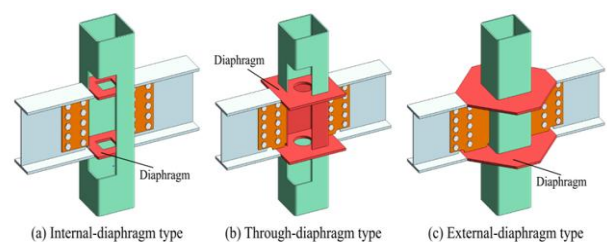

Fig-4: The typical beam-column connections.

The investigations on the connection behaviour of CFST column-to-beam joint implanted by steel rebars under cyclic loading by Mou et al. concluded that

- Most of the bending moment and plastic deformation of the whole column-to-beam joint occurs at the column-column connections. There was a noticeable rotational deformation at the connection between the upper and middle columns as opposed to the connection between the lower and middle columns.
- Strain distributions on the outer annular stiffeners and webs bolted to the beam indicated that their contribution to the deformation of CFST column-to-beam joints was limited.
- It was found that in the connection zone, steel tubes tended to axially deform mostly at the connections between the beam and the column flanges rather than at the webs of the column. Compression expansion of the infilled concrete is thought to be responsible for the bulging outward of the column flanges.

#### 4. EXPERIMENTS

Several scholars conducted experimental investigations on the performance of concrete-encased concrete-filled steel tubular (CFST) structures.

Experimental research and numerical simulation are conducted on square concrete-encased CFST stub columns after ISO-834 fire exposure in order to find mechanical properties is done by Kai et al. [7] temperature distribution and load versus displacement are calculated. From study it is concluded that compressive failure is the mode of failure noticed in the fire exposed concrete- encased CFST stub column. Time of exposure of specimen in fire and sectional area of core have significant influence on the reduction of axial compressive strength and axial stiffness of square concrete-encased CFST stub columns after the exposure in fire.

#### 5. EXPERIMENTAL PROGRAM TO FIND SEISMIC PERFORMANCE OF CONCRETE ENCASED CFST BEAM- COLUMN JOINTS.

In the study conducted by Wei Li et al. [1] Experimental investigation was carried out for joints made up of steel beams and concrete-encased CFST column. In his experiment constant axial loading is applied on top of the column, and the reverse cyclic loading was applied at the beam ends. The failure patterns, the hysteretic relations, the deformation and the strain distributions were recorded and analyzed.

For the experiments following data are used:

#### 5. 1 Material properties

A mild steel plate was cut into beam webs and flanges, then welded together and straight electric weld was applied to the steel tube for the column. Table 1 lists the material properties of steel.

In the test, two types of concrete were used, a core filling tube is for the inside steel tube, and an outer RC and slab are for the outside steel tube. The concrete placement was performed in two steps. At first, the steel tube of all specimens was filled with core concrete. After that, the outer concrete along with the slab concrete were placed together for all specimens. For each type of concrete specimen, the compressive strength of concrete cube ( $f_{cu}$ ) was obtained and the average strength value was calculated only if the strength error between tested cubes was less than 15%. The obtained concrete strength as well as the mixtures are presented in Table 2.

Table-1: Material properties of steel.

Components	t or d mm	$f_y$ N/mm <sup>2</sup>	$f_u$ N/mm <sup>2</sup>	$E_s$ N/mm <sup>2</sup>	$\delta$ %
Beam flange	10	386	472	2.14x10 <sup>5</sup>	36.7
Beam web	8	395	495	2.05x10 <sup>5</sup>	25.4
Tube	6	371	535	1.97x10 <sup>5</sup>	23
Rebar	8	343	516	1.91x10 <sup>5</sup>	23.1
	10	383	547	1.99x10 <sup>5</sup>	19.8
	14	396	523	2.08x10 <sup>5</sup>	24.1
	18	384	529	2.05x10 <sup>5</sup>	25.8

Table-2: Mixtures and properties of concrete.

Type	Core concrete	Outer concrete
Cement (kg/m <sup>3</sup> )	428	284
Coarse aggregate (kg/m <sup>3</sup> )	870	870
Fine aggregate (kg/m <sup>3</sup> )	783	783
Fly ash (kg/m <sup>3</sup> )	143	129
Water (kg/m <sup>3</sup> )	186	207
Water Reducer (kg/m <sup>3</sup> )	8.56	5.13
$f_{cu}$ (N/mm <sup>2</sup> )	69.7	65.7

### 5. 2 Loading apparatus

Two columns were simply supported, and both beam ends were connected to independently worked MTS actuators. The test setups for planar joints and 3-D joints are shown in Fig. 5 and Fig. 6, respectively. To apply the axial compressive load to the column, a hydraulic jack of 5000kN was used. In the next step, beams were subjected to reversible cyclic loads that were gradually increased keeping axial compressive load constant throughout the test. During the force control stage, the actuators were controlled at a rate of approximately 1 kN/s; during the displacement control stage, they were controlled at a rate of approximately 1 mm/s.

The experiments were finished when all three cycles of  $5\Delta y$  were completed or the joint strength dropped below 85% of the maximum load.

### 5. 3 Measurements

In MTS actuators, the cyclic loads and displacements at beam ends are directly measured by transducers. In order to measure strains at different locations, numerous strain gauges were installed and arrangement of transducers are shown in Fig. 7. These transducers are used for measuring joint shear deformations, relative rotation between column and beam etc.

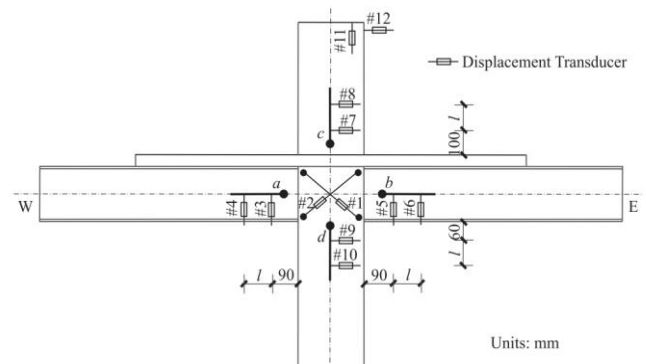

Fig-7. Arrangement of displacement transducers.

### 5. 4 Experimental results

The tests were controlled well and completed smoothly. Numerous failures of components were observed during and after the tests, including crushing and cracking of concrete, buckling of beam flanges and longitudinal bars, as shown in Fig. 8

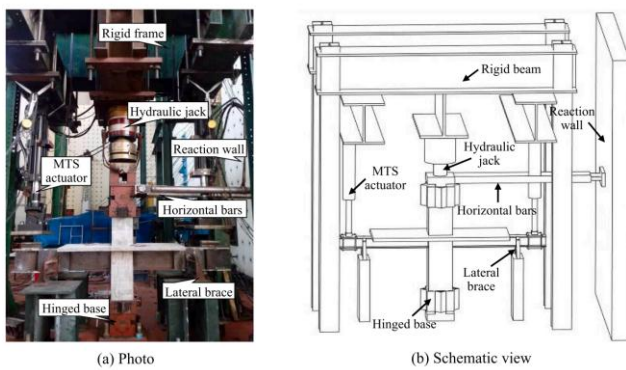

Fig-5: Test setup for planar joints.

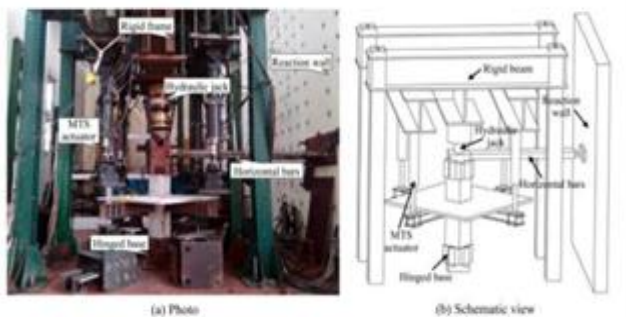

Fig-6: Test setup for 3D joints.



Fig-8: Typical component failures.

Within the parameter range of this study, following conclusions are made:

- Three types of failure were identified for the tested joint specimens: the beam bending failure, the panel shear failure, and the column compression-bending failure.
- As the beam-to-column strength ratio increased, the load carrying capacity increased, while the axial load level had little impact.
- The load-carrying capacity increased as the beam-to-column strength ratio increased, while the axial load level had minor effect. [1]

## 6. CONCLUSIONS

In this review concrete encased concrete filled steel tubular structure, its properties, components, connection behaviour, load carrying capacity etc. with a practical test is successfully studied and analyzed. From the review of the literatures and my studies it is concluded that concrete filled CFST structures perform well under loading conditions. As the beam- column strength ratio increased, little impact is shown on axial load. Few failure types are noticed such as beam bending failure, panel shear failure, compression bending failure etc.

As it is a composite material it shows properties of both steel and concrete. Due to excellent fire resistance, load carrying capacity, durability etc. it becomes a better choice for construction industry.

## REFERENCES

- [1] Wei Li, Li-Feng Xu and Wei-Wu Qian, "Seismic performance of 3-D steel beam to concrete-encased CFST column joints: Tests", 2021.
- [2] Ben Mou, Yingze Li and Qiyun Qiao, "Connection behavior of CFST column-to-beam joint implanted by steel rebars under cyclic loading", 2021.
- [3] Zhang D, Gao S and Gong J, "Seismic behaviour of steel beam to circular CFST column assemblies with external diaphragms", 2012.
- [4] Mou B, Li X and Bai YT, "Shear behaviour of panel zones in steel beam-to-column connections with unequal depth of outer annular stiffener", 2019.
- [5] Bai Y, Wang S and Mou B, "Bi-directional seismic behavior of steel beam-column connections with outer annular stiffener", 2021.
- [6] K. B. Manikandan and C. Umarani, "Understandings on the Performance of Concrete-Filled Steel Tube with Different Kinds of Concrete Infill", 2021.
- [7] Kai Xiang, Yan-chong Pan and Guo-hui Wang, "Axial compression analysis of square concrete-encased concrete filled steel tubular stub columns after fire exposure", 2017.
- [8] Fei-Yu Liao, Lin-Hai Han and Zhong Tao, "Behaviour of composite joints with concrete encased CFST columns under cyclic loading: Experiments", 2014.
- [9] Wei Li, Li-Feng Xu and Wei-Wu Qian, "Seismic performance of concrete-encased CFST column to steel beam joints with different connection details", 2022.
- [10] Yu-Feng An, Lin-Hai Han and Charles Roeder, "Performance of concrete-encased CFST box stub columns under axial compression", 2015.