

Solar based Pond Cleaning Machine

Purushothaman T¹, Maheshbala A², Karthick Prasath A³, Shanthi T⁴

¹²³Department of Electrical and Electronics Engineering, Kumaraguru College of Technology [Autonomous], Coimbatore, India

⁴Assistant Professor, Department of Electrical and Electronics Engineering, Kumaraguru College of Technology [Autonomous], Coimbatore, India

Abstract - Water contamination has been a key source of concern for the environment. The majority of water bodies, such as ponds, lakes, and streams, are heavily contaminated. Floating garbage is a significant pollutant. The floating garbage has been removed using machines. These goods are occasionally unlawfully dumped directly into a water body or wetland, or deposited along riverbanks or lakeshores in both urban and rural regions. Trash is also generated by people who fish or engage in other water-related activities. Trash, regardless of its source or sort, pollutes water. This project focuses on a pond cleaning machine powered by solar energy. The operation was carried out in response to the current state of our national rivers, which are dumping crores of gallons of sewage and are laden with pollutants, hazardous materials, and floating solid debris, among other things.



Key Words: Pond cleaning, Debris, Solar Panel, DC motor, Arduino UNO, Bluetooth Module.

Fig-1 : Floating waste in water bodies

1. INTRODUCTION

Ponds are a common sight in the Earth's geography. They are generally valued ecosystems that give humans with a variety of commodities and services. They provide not only a plentiful supply of precious water, but also valuable habitats for flowers and animals, mitigate hydrological extreme events (drought and floods), influence microclimate, enhance the landscape's elegant splendour, and provide numerous recreational opportunities. In India, ponds have a special significance. Pollution for the closing decades, there has been an explosive increasing in the urban population without corresponding growth of civic centres such as adequate infrastructure for the disposal of waste. Hence, as an increasing number of people are migrating to cities the urban civic services are becoming less. The suggested idea seeks to successfully clean water bodies without requiring a lot of manual labour and to keep the machine's design cost low in comparison to other machines on the market.

2. MOTIVATION

Dry waste, such as plastic waste or bottles, float on the water surface because they have a lower specific weight than water, making them visible on the water surface. Water logging is becoming more of a concern as a result of plastic, solid waste, and metal, which encourages bug proliferation and diseases like malaria. Because this is dangerous to human life, the concept for this research arose.

As a result, solid trash must be removed from riverbeds, ponds, and other bodies of water. Nowadays, most waste collection by humans is done with a scoop net with a long handle. However, when the amount of garbage is large, the operation necessitates a lot of effort from the cleaning crew. The goal of our suggested system is to reduce or eliminate the problems that arise when utilising a man-operated equipment, as well as the increased trash disposal rate.

3. PROPOSED WORK

Our main goal is to lift waste trash from the water's surface and deposit it in a tray. Currently available river cleaning machines are primarily powered by gasoline or diesel. We employed solar electricity as the primary source of energy in our project. As a result, the project's name has been changed to "Solar Based Pond Cleaning Machine".

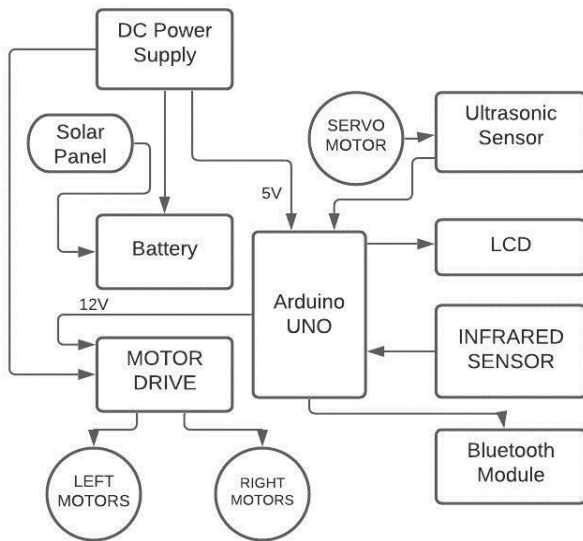

Fig-2 : Block diagram

4. WORKING

In this model we have used six motors. All of them are DC gear motor. First and second motor is used for conveyor to lift wastage from river and the speed of the conveyor motor is 30 RPM and operated at 12 volts. The balance four motors are used for the vehicle movement. This movement includes Forward, Backward, Left, Right, Reverse and Stop operation. These all six motors are operated at 12 volts DC. An ultrasonic sensor is placed at the centre of the model in front view. This ensures the distance of the waste particle from the vehicle for measuring purpose. Two Infrared sensors are used in this model for detection purpose and they are fitted at left and right corner of vehicle's front side. The wastes collected from the pond are stored in the tray which is fitted inside the vehicle. The collected wastages are thrown on the collecting tray with the help of conveyer. The LCD display in this model is used to display the distance of the waste particle from the vehicle in centimetres and to display how much grams of wastes are collected.

For all control operations in our vehicle, we used an Arduino Uno. Our vehicle's heart is Arduino Uno. The Arduino Uno uses the Bluetooth module to regulate the motor's speed. Because we have a Bluetooth module fitted for remote operation, we can operate the vehicle from our phone. Our vehicle is easily controlled by the phone. By the use of our vehicle the required human effort to clean water surface will be very less.

5. EXPERIMENTAL RESULTS AND ANALYSIS

5.1 MOVEMENTS

S.No.	Ultrasonic Reading (cm)	IR Reading (logical)		Movement
		L.IR	R.IR	
1.	11-30	1	1	Forward
2.	6-10	1	1	Reverse
3.	-	1	0	Left
4.	-	0	1	Right
5.	0-5	1	1	Stop

Here,

L.IR – Leftside IR sensor

R.IR – Rightside IR sensor

5.2 MOTOR OPERATION

S.No	Operation	Motor rotation	Motor Condition
1.	Forward	Clockwise	M1,M2, M3,M4- same speed
2.	Reverse	Anti-Clockwise	M1,M2, M3,M4- same speed
3.	Left	Clockwise	M1,M2-same speed(low) M3,M4-same speed (high)
4.	Right	Clockwise	M1,M2-same speed (high) M3,M4-same speed(low)
5.	Stop	-	M1,M2, M3,M4- idle state

Here,

M1,M2,M3,M4 – DC Motor

6. CONCLUSION

This pond water cleaning machine design and analysis is based on literature and research from many journals and papers that are relevantly available, and it is constructed in accordance so that it may provide flexibility in operation. It is very cheap and very valuable for society based on its design and estimation of cost and availability. Our project accomplished an impressive feat in terms of environmental protection and is particularly useful for small-scale projects.

7. FUTURE SCOPE

In future, this model can be developed into large scale for actual practice in big rivers or lakes.

- By expanding the machine's capacity, the vehicle can be developed for major rivers such as the Narmada and Ganga.
- For further development, we can use devices such as a camera, a buzzer, and sensors.

8. REFERENCES

[1]<https://www.britannica.com/explore/savingearth/wp-content/uploads/sites/4/2019/03/plastic-pollution-hero.jpg>

[2] IEEE July 2017, Amphibious Clean-up Robot, NanPan, Lifeng Kan, Yajun Sun, Jinlun Dai.

[3] IJAERD - Volume 05, Issue 03, March 2018, Design and Fabrication of River Waste Collector, Mahto Ravishankarkumar Ravindrabhai, Dehadray Vaibhav, Kaka Smit, Prof. Ankur Joshi.

[4] ICCAS October 2017, A Floating Waste Scooper Robot on Water Surface, Niramom Ruangpayoongsak, Jakkrit Sumroengrit, Monthian Leanglum.

[5] IJRSI - Volume 4, Issue 6, June 2017, Design and Removal of Floating Wastes on Water Bodies, Aishwarya N. A, Arpitha M, Chaithra K, Chira Shankar, Navyashree D.