

Design and Analysis of Brat Scramble Motorcycles

A Review

Kazingufu N. Fortunat¹, Panchal Bhagyesh², Patel Pankaj³, Ansari Shakil⁴, Krupal Shah⁵, Bharat Dogra⁶

^{1,2,3,4} Student of Automobile Engineering Department, IITE, Indus University

^{5,6} Asst. Prof. Department of Automobile Engineering, Indus University

Abstract A review of the design and analysis of the frame has been carried out in this paper. In a Two-Wheeler, the frame is crucial since it bears the weight of the vehicle. It is critical to conduct various tests and analyses on various materials and frameworks. In this article, software analyses such as ANSYS, CATIA, and CAD were discussed. Different methodologies such as the Finite element method (FEM), Experimental modal analysis (EMA), the modal parameters, natural frequency, and mode shape of the structure might be determined to acquire a better knowledge of the frame's challenges.

Keyword: Two-Wheeler, Frame, FEA, ANSYS, CATIA, CAD

1. INTRODUCTION

The Scrambler's origins may be traced back to the turn of the twentieth century in jolly old England, where a group of mad Englishmen began dabbling in a new type of motorcycle racing that took place off the main path.

The term "brat style" was coined by Brat Style, a bespoke motorbike shop. Their custom built "language" was copied all over the world, and they were dubbed "Brat style" motorcycles, as if they were a brand.

1.1 Scrambler Motorcycle

It's a bike that can be used both on and off the road. Scramblers may appear to be a new phenomenon, but they've been around for quite some time. The bikes were pared down to save weight for speed, given taller suspensions, spoked wheels and knobby tyres, and high exhaust pipes for ground clearance to make them suitable for the landscape races. Headlamps are smaller and set on shorter brackets, while the handlebars themselves are larger and braced across their width. Exhausts are often high, seats are shorter and occasionally thicker, and wheels are always spoked on aluminium rims. [1]

1.2 Brat Motorcycle

A brat type bike is a non-rigid custom with either a flat, slab seat long enough to ride two-up or a solo seat that has been

lowered via modest frame modification. It has a lowered stance and has had most of the extraneous equipment removed, such as fairings and chrome. Mini-apes, superbike bars, and motocross bars are all OK, but clip-ons are not. Bike with moto-styled bars commonly falls into the "brat tracker" category, especially if slightly knobby tyres are installed. [18]

2. Literature Survey

Raut et.al, [2] has describe various type of two-wheeler chassis frame and this includes Backbone Frame, Diamond Frame, Single Cradle Frame, Double Cradle Frame and Perimeter Frame. The Backbone Frame is one of the cheapest and simplest frames to make it give a great flexibility in design and it is mostly use in naked and off-road motorcycles such as ex-hero Honda CD 100. A Diamond frame is one of the frames that are mostly found in India and these frames are of the shape of the diamond bikes with this type of frames are Hero CBZ Star, Yamaha FZ and Bajaj Pulsar 135 LS. Motorcycle racing study has revealed that major benefits are to be upsurge in terms of rigidity by connecting the steering head to the swing arm in as short a distance as possible. This is the perception behindhand the perimeter chassis. In India there is only the Bajaj Pulsar 200NS and Yamaha R15 are the bike with the perimeter frame.

Inzamam et.al, [3] uses CATIA software for designing the chassis of the existing two-wheeler and after the proper design he did the analyzation of the system using ANSYS software.

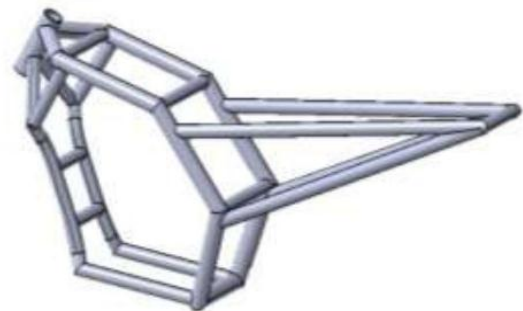

Figure 1: CAD model of chassis
Inzamam [3]

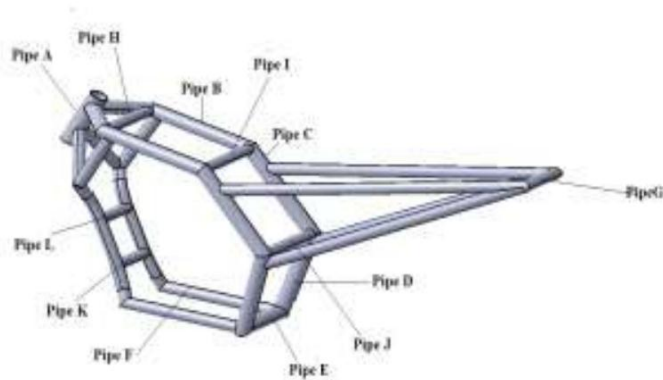

Figure 2: Detail nomenclature of existing chassis Inzamam [3]

Table 1: Dimensions of Chassis. Inzamam [3]

Sr. No	Pipe	Dimension
1	A	O.D.=48.30 mm, I.D.=42.76 mm
2	B	O.D. = 42.2 mm, I.D. = 36.66 mm
3	C	O.D. = 42.2 mm, I.D. = 36.66 mm
4	D	O.D. = 42.2 mm, I.D. = 36.66 mm
5	E	O.D. = 42.2 mm, I.D. = 36.66 mm
6	F	O.D. = 33.4 mm, I.D. = 27.86 mm
7	G	O.D. = 33.4 mm, I.D. = 27.86 mm
8	H	O.D. = 33.4 mm, I.D. = 27.86 mm
9	I	O.D. = 33.4 mm, I.D. = 27.86 mm
10	J	O.D. = 33.4 mm, I.D. = 27.86 mm
11	K	O.D. = 33.4 mm, I.D. = 27.86 mm
12	L	O.D. = 33.4 mm, I.D. = 27.86 mm

Prateek et.al, [4] has mentioned that the frame of a two-wheeler chassis is a skeleton on which parts like gear box and engine are fixed on. For frame to resist shock, vibration, twist and other stresses, it has to be durable so that it does not break easily. This is why the chassis is considered as the most important part of the vehicle. The chassis experiences different forces or loading conditions. Static, Dynamic, compressive, tensile ANSYS and Hyper works.

Djoko et.al, [5] To create a new Finite Element (FE) model motorcycle frame Djoko uses the computer-Aided Design (CAD) to create the technical drawing. With the object of making an exact image and the geometry of the FE model is then evaluated based on the real prototype. For confirming the FE model, the experimental modal analysis is done. According to this research, the chassis model is suspended using rubber ropes on a rigid jig and excited by an impact hammer. The load applied to the model will give satisfactory results that can be noticed by the accelerometer fitted at another point on the chassis.

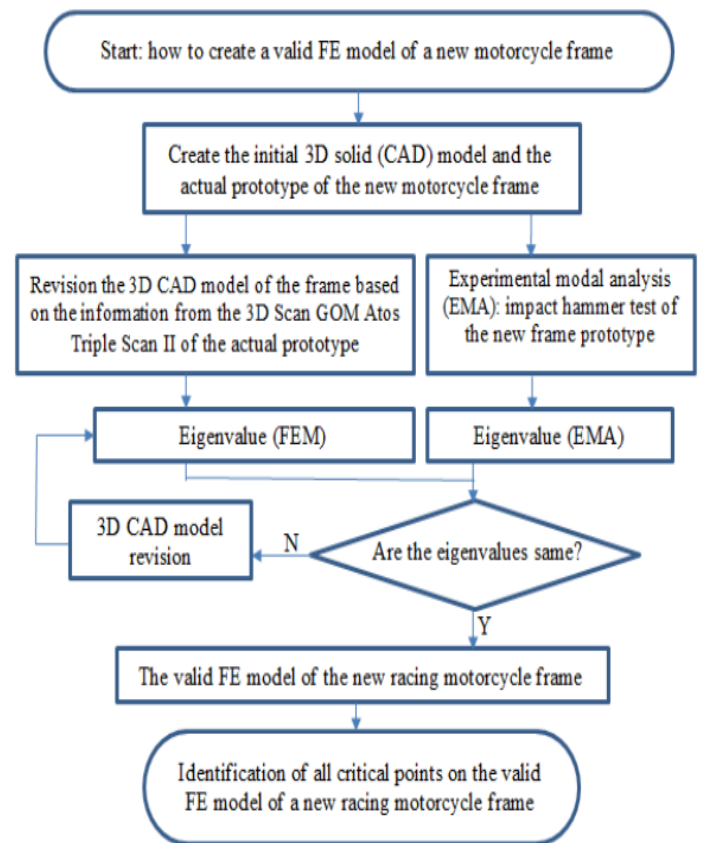

Figure 3: Method for creating a valid FE model of a new. Djoko [5]

According to Sasidhar et.al, [6] motorcycle frame is a fundamental structure of the bike. It gives the hinge points for both front and rear suspension and supports the rider and any pillion or luggage. A bike frame can be made of various materials like alloy steels, titanium alloys etc. But because of the various considerations like strength, Toughness and for this reason he imagined creating a frame with low carbon steel.

The properties of low carbon steel he chose:

1. The carbon content of the low carbon steel ranges from 0.05 to 0.320%
2. As due to the low carbon content this material gives the tendency of strength, Toughness, Ductile, best weld ability, Formability, good wear resistance.

Diogo et.al, [7] has stated that since the geometry tends to convert bending loads into axial loads leading to stiffer and lighter structures, Triangulated frames are the best solution for deformation problems on the frame chassis. Fixing the engine on the frame in a way that is a structural element supporting both the steering column and the rear suspension.[7]

The engine head's support has the objective of partially supporting the engine's weight. Due to design Doubts, it was well-thought-out that the motorcycle's weight was applied in the engine and that it was equally divided by all of its supports. After the analyzation it was established that this component resists yielding since its minimum safety factors is of 5.18 (45 MPa of maximum stress) located in the link to the backbone.

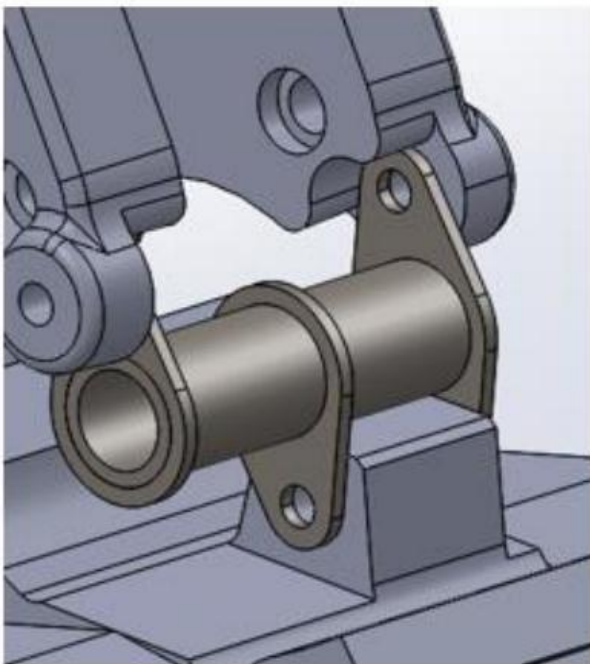

Figure 4: Engine Head's Support Diogo [7]

In modal analysis of two-wheeler chassis Santosh et.al, [8] has discussed that modal analysis is an effective tool for describing, considering and modelling structural dynamics. The performance of a structure in a shown frequency range can be designed as a set of specific modes of vibration. To represent a complete dynamic description of the structure, the modal parameters of all the modes with in the frequency range of interest is used. Average frequency results on experiment used the style shapes of the structure to decrease the size, disengage the derivation of motion when not using the modal or damping, and make the mathematical result more efficient. In his comparison between the pulsar 150cc chassis and passion chassis, he concluded that the pulsar 150cc chassis is very much better because of its deformation is very less compared to the one of the passion chassis. The comparison tables are shown below.

Table2: Mode distribution for pulsar 150cc chassis Santosh [8]

Mode	Frequency
1	19.157
2	49.723
3	55.455
4	78.605
5	87.949
6	94.276
7	95.702
8	103.73
9	143.18
10	184.12

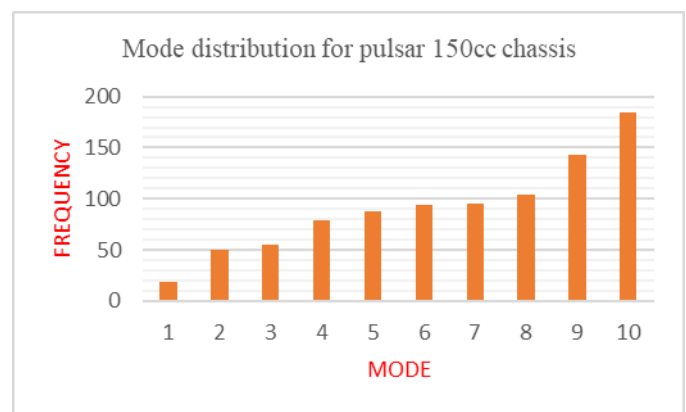
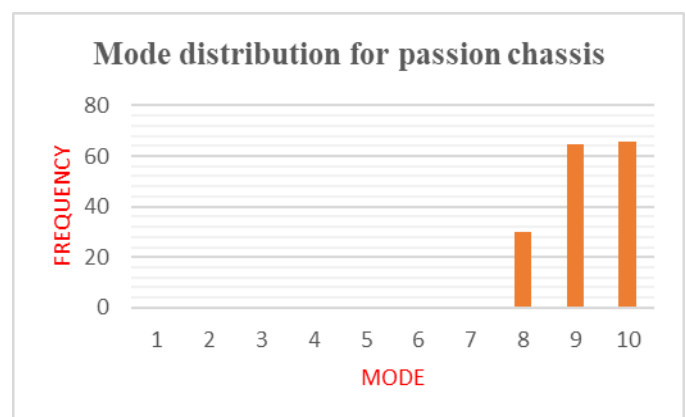

Table 3 : Mode distribution for passion chassis Santosh [8]

Mode	Frequency
1	0
2	0
3	0
4	0
5	5.99E-03
6	1.10E-02
7	1.60E-02
8	29.964
9	64.491
10	65.931



Saurabh et.al, [9], The Finite Element Analysis (FEA) is a numerical technique for discovering an approximate solution to boundary value problems for partial differential equations by subdivision of a problem domain into an easy part, called finite elements. Several methods from the calculus of variations are used to solve the problem by minimizing an associated error function. In engineering, FEA is used as a digital experiment tool for carrying out engineering analysis. It entails the use of mesh generation techniques for breaking down a large problem into smaller components, as well as the usage of FEM-coded software. The complex problem in FEA is typically a physical system with physical mechanisms such as the Euler-Bernoulli simple calculation, the heat equation, or the Navier-Stokes equations expressed as PDE or integral equations, and the divided small elements of the complex problem represent different areas in the physical system.

Prakash et.al, [10] has done a Finite Element analysis by comparing three types of materials properties used on chassis. The type of materials is: steel, Aluminum alloy 6063, Carbon fiber and titanium. The comparisons are shown in tables below

Table 4: Material properties Prakash [10]

S.No	Material	Young's modulus E	Poisson's Ratio U	Density ρ	Yield Stress σ _{yield}	Ultimate Tensile Stress σ _{uts}
1	Steel	210 GPa	0.3	7850kg/m ³	350M Pa	490MPa
2	Aluminum Alloy 6063	68.9GPa	0.33	2700kg/m ³	214M Pa	241MPa
3	Carbon Fibre	73.1GPa	0.33	2780kg/m ³	324M Pa	469MPa
4	Titanium	119GPa	0.34	4430kg/m ³	880M Pa	900MPa

Table 5: Comparative analysis of steel chassis with other types Prakash [10]

S.No	Material	Max. Stress	Max. Displacement
1	Steel	43.44MPa	0.11441mm
2	Aluminium Alloy 6063	43.70 MPa	0.34746 mm
3	Carbon Fibre	43.59MPa	0.1846mm
4	Titanium	35.14MPa	0.11400mm

After the comparison he saw that the results of finite element analysis of chassis the stresses are maximum at joint location and it also shows that all the materials have stress values less than their respective yield stress values. then it is concluded that the design is safe.

Isac et.al, [11] did a stress analysis of the selected conceptual solution and this analysis was done in a software Abaqus. He created a CATIA software system to make a 3D model frame and it is important to make a geometric representation. The most necessary thing is that the mesh shows the geometry of the very structure he was designing. This means that in order to be able to follow the outlines of the structure itself, the element should be of suitable size. the material also should be of properly selected so that the design representation can be as much realistic.

Narendra et.at [12] did a structure analysis of a two-wheeler suspension frame using steel with Bamboo and carbon Epoxy. This test was done by elastic analysis. Below we have tables showing the properties of this material.

Table 6: Suspension frame with Steel with Bamboo as material Narendra [12]

S.No	Model of suspension frame	Load Applied (N)	Total deformation (m)		Von-mises stress (Pa)	
			Max	Min	Max	Min
1	Circular cross section	750	9.5593e-6	0	2.58887e7	47.397
2	Oval cross section	750	1.6779e-5	0	3.2404e7	71.756
3	Rectangular cross section	750	6.532e-6	0	9.1225e6	135.19

Table 7: Suspension frame with Carbon Epoxy as material Narendra [12]

S.No	Model of suspension	Load Applied (N)	Total deformation (m)		Von-mises stress (Pa)	
			Max	Min	Max	Min
1	Circular cross section	750	1.5447e-5	0	2.9342e7	156.04
2	Oval cross section	750	1.3994e-5	0	2.9993e6	0.1766
3	Rectangular cross section	750	4.336e-6	0	7.911e6	39225

Looking at the results, for all the materials the stress values are less than their corresponding permissible yield stress values. After the experiment it is shown that model modifications frame is safe. The weight of the frame was also reduced up to 30%.

Neeraja et.al, [13] The frame, suspension, wheels, and brakes make up the two-wheeler chassis. The two-overall wheeler's style is defined by the chassis. The frame acts as a framework to which components such as the gearbox and

engine are attached. Steel, aluminium, or an alloy can be used. A spring is connected to a viscous damping element, a piston, in an oil-filled cylinder of a motorcycle suspension frame system. Single cradle frame, Double cradle frame, Backbone frame, Perimeter frame, and Trellis frame are some of the classifications. Computer-aided design (CAD), sometimes known as computer-aided design and drawing (CADD), is the field of computer technology to the design of a project. It's primarily used for thorough engineering of 3D and/or 2D models. Pro/ENGINEER Wildfire, for example, is the industry standard in 3D product design, with industry-leading productivity features that promote best design practices while assuring compliance with industry and business standards. There are various modules in Pro/Engineer, such as Part design, Assembly, Drawing, Sheet metal, and Manufacturing. In addition, FEA (Finite Element Analysis) was invented in 1943 by R. Courant, using the Ritz method of quantitative analysis and variable equation reduction to derive approximate results to vibration structures. To confirm our design, we performed structural and modal study on the suspension frame using four different materials, including Steel SS 316. The stress levels for the materials are fewer than their maximum values, based on the results.

H. Rashid et.al, [14] Superbikes with a dry weight of more than 100 kg rarely come with a double-stand, such as is commonly found on much lighter lower CC motorcycles. This double-stand functions as a temporary stand that places the motorcycle in a vertical standing position, which clear the way for the ease of either periodic or ad-hoc maintenance work. To smooth this, a special type of jack is needed to safely lift the bike. The common operating idea of today's superbike paddock stands is to lift either the front or rear tyre, depending on the maintenance work that needs to be done. The design process involved in designing the superbike paddock stand are: - Start, Identification of Needs, Idea & Concept Generation, Preliminary Design & CAD Modelling, Detail Design, Calculation & FEA Simulation, Fabrication, Assembly & Finishing, Testing & Verification. To analyses the maximum stresses acting on the designed stand, FEA was performed on the 3D CAD model. The analysis results consist of the deformation, von Mises Stress and translational displacement that occurs on the 3D CAD model of the designed stand, obtained through an FEA simulation using the software. However, the FEA revealed that scarcely any deformation befallen.

Maulik et.al, [15] The frame is a framework that items such as the gearbox and engine are mounted to. It is critical that the frame does not tighten up on a rough or pitted road surface. It should also not be transmitted to the body as a distortion. The resonance will occur if the natural frequency of the two-wheeler frame coincides with the stimulation frequency. The frame will experience dangerously significant oscillations as a result of resonance, which may result in excessive deflection and failure. Experimental modal analysis, which is the process of obtaining the modal

characteristics of a structure for all modes in the frequency range of interest, is critical for resolving the issues. The fundamental goal of this theory is to use experimental modal analysis to determine the natural frequency, damping, and mode shape of a two-wheeler frame. Preparation: defining the issue, assigning loads, constraints, and solving is the solution. Further processing and viewing of the results are done in the post-processing stage.

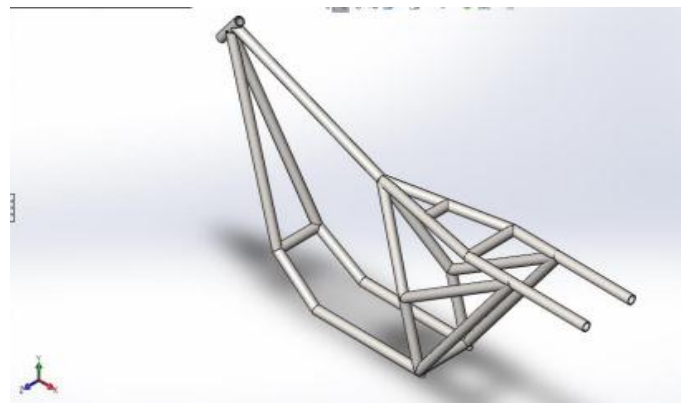

Figure 5:Geometry of Modify Double Cradle Frame using static analysis Maulik [15]

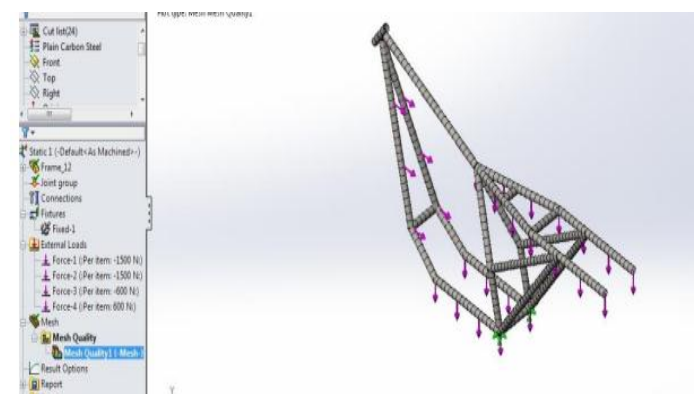

Figure 6: Meshing of Modify Double Cradle Frame using static analysis Maulik [15]

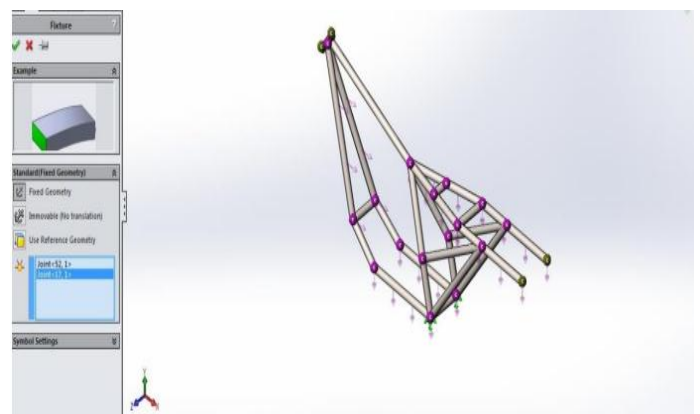

Figure 7: Boundary condition of Modify Double Cradle Frame using static analysis Maulik [15]

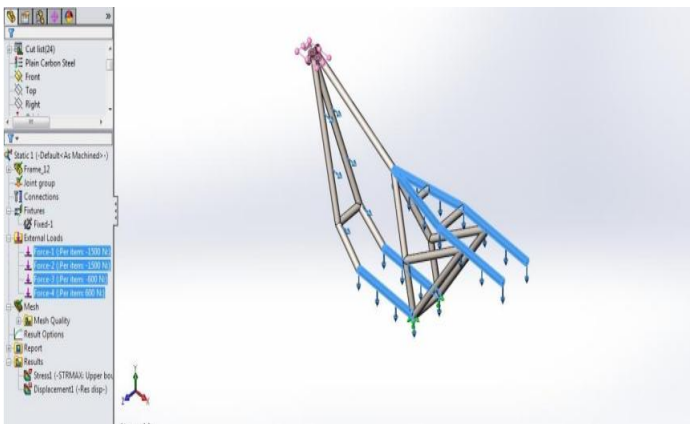

Figure 8: Force applying on Modify Double Cradle Frame. Maulik [15]

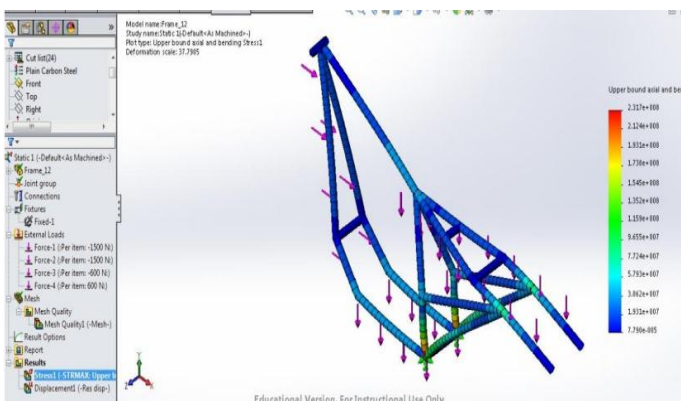

Figure 9: Von mises Stress analysis of Modify Double Cradle Frame Maulik[15]

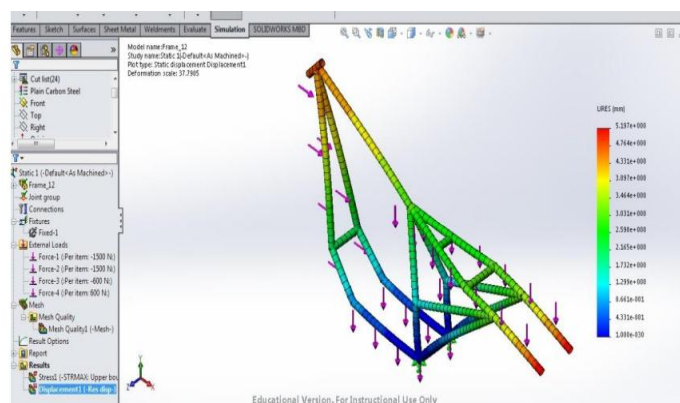

Figure 7: Deformation of Modify Double Cradle Frame Maulik [15]

Bala et al, [16] The motive of this thesis is to ameliorate the fuel efficiency of motor bike by reducing the weight of its frame without affecting the rudimentary functionalities, dimensions and performance. A topology optimization technique was used to reduce the frame's weight. In the first instance the load and stresses acting on the frame was studied. Material of the frame was chosen as Stainless Steel SS-316 and the frame was geometrically modelled using

Autodesk Solid works 2018. After optimization, the weight of the frame was minimized from 3.0695 kg to 2.215 kg with the weight reduction of 27.84%. The weight reduction shows that the topology optimization is an efficacious technique, without reimbursing the performance of the frame. The research clampdown is all the components of the automobile may be topology optimized for the weight reduction, thereby meliorate the fuel efficiency. Innovative design / Improvement in design also possible. The weight of a vehicle is reduced by reducing the frame's weight. Better fuel economy is achieved by reducing the weight of the vehicle. Topology optimization lowered the weight of the motorcycle frame. The regions of material removal at the frame were determined without adjusting the performance.

Arka et al, [17] The first step is to develop a 3D solid model of the frame by using Auto Cad Solid works software. Based on this model, the actual frame prototype was built from Stainless Steel SS 316 material and welded together by DR4000 welding robot using MIG welding process. The 3D solid model will then be revised based on the geometries of the real prototype obtained by the Atos Triple Scan II 3D Scan GOM. Furthermore, all welding parameters in the 3d view of the frame are assumed to have bead welding. Sim-Designer 2017 is used to create the meshing of the FE model. In order to acquire the dynamic characteristics of the FE model, Nastran 2014 SOL 103 is used to do a finite element analysis (FEA). The real frame prototype is subjected to experimental modal analysis (EMA). The frame sample is handed from a fixed jig in a free-free condition and subjected to an impact hammer test. Frequency response function (FRF) was then obtained from the ratio of a response and a force that is acquisition in a dynamic signal analyzer. To confirm the FE model, the experimental modal analysis (EMA) of the actual frame sample is performed. Frequency response function (FRF) was then obtained from the ratio of a response and a force that is acquisition in a dynamic signal analyzer. The eigenvalue of the FEA is validated using the EMA's eigenvalue. The simulation's frequency response reveals that the major reaction occurs at 3 Hz, which is the first natural frequency. These resonance conditions can be used to conduct a safety study of the frame construction. The proposed method is an effective tool for analyzing and designing a new motorbike frame.

3. CONCLUSIONS

As we evaluate our research, we reach a conclusion that:

- Steel and Aluminum Alloy 6063 it is most suitable material for building our project frame, it is also readily available, easy to find in the market and it is much preferable in the automobile industry. The ultimate tensile strength of steel and Aluminum Alloy 6063 is 490MPa and 241 MPa respectively. In addition to that, the young's modulus of the steel and aluminum is 210 GPa and 68.9 GPa respectively. However, Titanium is the strong and durable material which can be used to make

chassis of two-wheeler but as per the cost, it is very expensive and difficult to find in the market.

- After analyzing the review papers, we can conclude that the modified single cradle frame is the most appropriate frame to build a strong and durable two-wheel vehicle which is less complex.

REFERENCES

- [1] Siddhi Hatle1, Shubham Dhuri2, Vinayak Dubey3, Rajiv Patil4, Nihar Vaity5 "SCRAMBLER: A TYPE OF MOTORCYCLE,"/ International Research Journal of Engineering and Technology/Vol.07/ 2020
- [2] Abhijeet R. Raut1, Dr. A.D. Shirbhate2, "Design and Analysis of Two-Wheeler Composite Chassis Frame a Review"/ IJSRST/Vol.3/ 2017
- [3] Mr. Inzamam Mulla1, Prof. A. M. Qureshi2, "DESIGN ANALYSIS AND OPTIMIZATION OF TWO-WHEELER CHASSIS FOR WEIGHT REDUCTION" International Research Journal of Engineering and Technology/Vol.06,2019
- [4] Prateek Chaturvedi, "Analysis and Proposed Fabrication of Two-Wheeler Hybrid Chassis" international Conference on Automation, Computational and Technology Management, 2019
- [5] Djoko Setyanto1* , Arka Dwinanda Soewono2 , Andi Wibowo3 and Rugerri Toni Liong4, "Design of a Motorcycle Frame at an Automotive Company in Indonesia", International Journal of Engineering Research and Technology, Vol.13,2020
- [6] Sasidhar Gurugubelli* ,Rajiv Aditya Jayanthi, Hemanth Chelluri, Sai Rajeev Kilari, Sai Kiran Cheemala , Dinesh Allu "Design and Fabrication of Electric motor Bike Frame", International Journal of Scientific Research in Mechanical and Materials Engineering ,Vol. 2 2018
- [7] Diogo Rechená, Luís Sousa, Luís Eça, "MOTORCYCLE CHASSIS ANALYSIS" IDMEC, Vol. 2014
- [8] Santosh Hiremath *, Naresh Kumar, Nagareddy.G, Lakhn Rathod, "MODAL ANALYSIS OF TWO-WHEELER CHASSIS" INTERNATIONAL JOURNAL OF ENGINEERING SCIENCES & RESEARCH TECHNOLOGY, Vol. 2016
- [9] Saurabh Rege1, Chirag Khatri2 , Mrudul Nandedkar3 , Noopur Wagh4, "Design and Analysis of Frame for Electric Motorcycle", International Journal of Innovative Research in Science, Engineering and Technology, Vol.6 2017
- [10] #1Prakash Katdare, #2S.C. Shilwant, "Design Optimization of Two-Wheeler (Bike) Chassis" International Engineering Research Journal, Vol 2018
- [11] Isad Saric, Nedim Pervan, Mirsad Colic and Adil Muminovic, "CONCEPTUAL DESIGN AND STRESS ANALYSIS OF THE COMPOSITE FRAME OF DIRT JUMP MOUNTAIN BIKE" International Journal of Mechanical Engineering and Technology, Vol 9, 2018
- [12] R. Narendra Kumar1 Ch. Mani Kumar2, P.Surendra3 , M.V. Kiran Kumar4 P.Chaitanya Krishna5, "STRUCTURAL ANALYSIS OF A TWO WHEELED SUSPENSION FRAME BY USING STEEL WITH BAMBOO AND CARBON EPOXY" IJCRT, Vol 6, 2018
- [13] CH Neeraja, C.R.Sireesha, D.Jawaharlal, "STRUCTURAL ANALYSIS OF TWO-WHEELER SUSPENSION FRAM", International Journal of Engineering Research & Technology, Vol 1, 2012
- [14] H. Rashid1 , A.H. Abdullah1 , M.H. Mohd Noh1 , A.H. Abdul Hamid1 and N.M. Zainal Abidin1 "DESIGN OF A SUPERBIKE PADDOCK STAND USING CAD AND CAE TOOLS", International Journal of Automotive and Mechanical Engineering, Vol. 5, 2012
- [15] 1Maulik Lohia, 2Prof. Mohsin Bukhari, 3 Prof.Dhaval P Patel, 4 Amarishkumar J.Patel, 5 Sunilkumar N.Chaudhari, "Stress and Rigidity Analysis of Bike Chassis", 2015
- [16] C. Bala Manikandan a*, S. Balamurugan b, P. Balamurugan a, S. Lionel Beneston a "Weight reduction of motorcycle frame by topology optimization", International Scientific Journal published monthly by the World Academy of Materials and Manufacturing Engineering, Vol. 2018
- [17] Djoko Setyanto1* , Arka Dwinanda Soewono2 , Andi Wibowo3 and Rugerri Toni Liong4 "Design of a Motorcycle Frame at an Automotive Company in Indonesia" International Journal of Engineering Research and Technology, Vol 13, 2020
- [18] <https://www.bikeexif.com/tag/brat-style>