

Mathematical Thermal Model of a House

Shridhar Koppal¹, Prasanna Wagh², Akshay Patil³, Shubham Bhaingade⁴

¹B.E, Department of Mechanical Engineering, L.T.J.S.S. Lokmanya Tilak College of Engineering, Navi Mumbai, Maharashtra (India)

Abstract - This paper presents an analysis of heat & temperature & how it affects the thermodynamics of a complex body such as a house & predict the temperature variation. For this, the model takes into consideration the different physical properties of a house & the weather around it. The analysis is done on the outside vs inside house temperature & the cost of electricity.

Key Words: Thermal model, House, Thermostat, Scilab, Thermodynamics

1. Introduction:

Speaking about human comfort ASHRAE (American Society of Heating, Refrigerating and Air-Conditioning Engineers) states "Human comfort is that condition of mind which expresses satisfaction with the thermal environment". A house is a complex permanent structure comprising of different components such as RCC construction, bricks, woods, glass, steel & other metals etc. Each & every component affects the temperature distribution in the house. The number of people & various appliances also affect how the temperature is distributed across the house. The best way to analyse & improve this temperature control is to prepare a model calculating the temperature variation by taking all the affecting factors into account. Improper thermal design of the house not only lead to human discomfort but also increased cost & wastage of energy.

2. Problem statement:

When constructing a house, it is paramount that the heat flow & temperature gradient is kept in mind as it is utmost important for the inhabitants' comfort. An ideal thermally designed house also resources energy intake & thus prevents wastage of precious natural resources. The interaction between the heating system & thermal demand of a house is complex due to various factors such as weather, outside temperature, inhabitants' comfort & even economic status. The physical properties & characteristics of the house also play an important role.

3. Methodology:

For the following experiment & study, a simple remote house is selected. The house is rectangular in shape & has 1 room. The house has gable roof, angled at 40° at the apex. The house contains 6 windows of plain glass. The house is situated in a cold region with no humidity for ease of calculation. Due to the thermal conditions, thermostat & heater are used for temperature control.

4. Model of the house:

4.1 Project Parameters of the model:

SR. No	Parameter	Value	Unit
	House Dimensions		
1.	House Length	40	M
2.	House Width	15	M
3.	House Height	5	M
4.	Roof Angle	40	Degrees
5.	No. of Windows	6	
6.	Window Height	1	M
7.	Window Width	1	m
	Material Parameters		

8.	Wall Conductivity	0.038*3600	J/Hr/m/C
9.	Wall Thickness	0.2	m
10.	Window Conductivity	0.78*3600	J/Hr/m/C
11.	Window Thickness	0.01	m

Table -1: Project Parameters

4.2 Components:

- 1. Thermostat:** Thermostat is a regulating device component which senses the temperature of a physical system & takes action so that the system’s temperature is near the pre-determined set point. The thermostat is a closed loop control device which means it has a feedback element & controls the ambient temperature of the house by adjusting the heater output. The thermostat compares the current temperature of house with the required room temperature. According to the feedback received, the thermostat turns ON or OFF & gives information to heater.

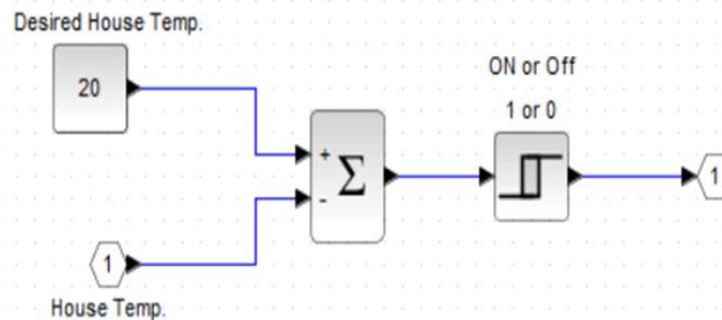

Fig -1: Superblock of Thermostat

- 2. Heater:** An electric heater converts electric energy into heat energy & outputs it to the system to raise the ambient room temperature. Air is introduced into the heater & the temperature of this air is increased & released into the system. The recirculated air is mixed with outside air & passed through a pre-heat coil to prevent freezing of water & to control the evaporation of water. Further the air is passed through a re-heat coil to raise the temperature of air to required dry bulb temperature. This conditioned air is distributed in the conditioned space via fans of a dedicated ventilation system. The electric heater uses forced convection method to heat the air.

When signaled by thermostat hot air blows at a constant flow rate.

$$\frac{dQ}{dt} = \frac{Thouse - Tout}{Req}$$

Rate of heat gain by Heater:

$$\frac{dQ}{dt} = \frac{dMair}{dt} * c(Theater - Thouse)$$

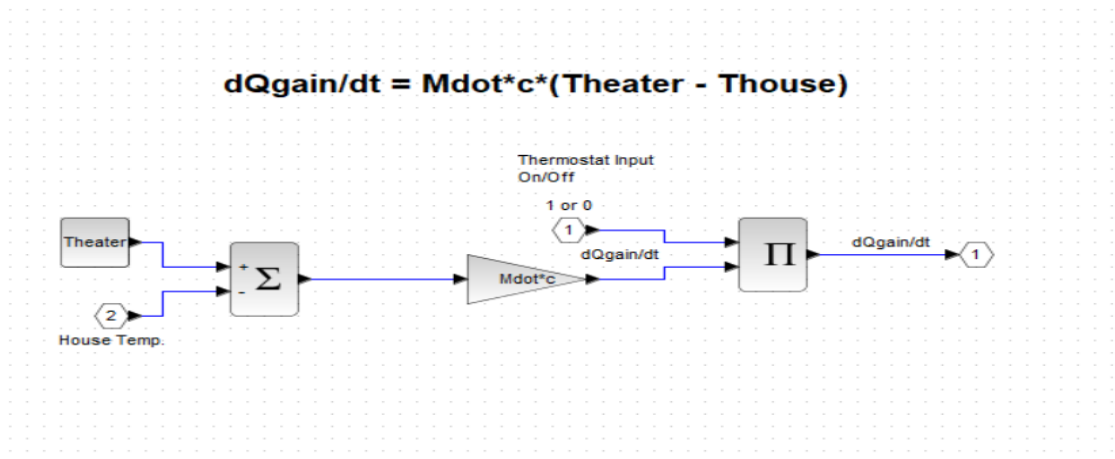

Fig -2: Superblock of Heater

3. **House:** The house is the system containing thermostat & heater. The boundary of the system i.e., the walls of the house do convective heat transfer with the surrounding air.

Rate of heat loss equation: Thermal energy loss from the room is by convection through the walls & windows.

$$Q_{loss} = \frac{k.A(T_{house} - T_{out}).t}{D}$$

$$\frac{Q_{loss}}{dt} = \frac{k.A(T_{house} - T_{out})}{D}$$

$$\frac{kA}{D} = \frac{1}{R} \quad \text{where R is thermal resistance.}$$

$$\frac{dQ_{loss}}{dt} = \frac{(T_{house} - T_{out})}{R}$$

Changing room Temperature equation.

$$\frac{dT_{house}}{dt} = \frac{1}{M_{air} \cdot C} \left(\frac{dQ_{gain}}{dt} - \frac{dQ_{loss}}{dt} \right)$$

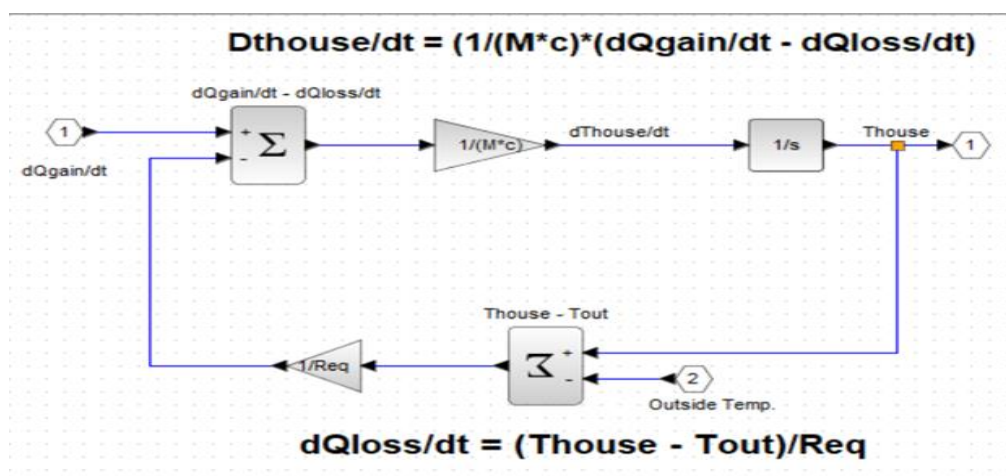

Fig -3: Superblock of House

5. **EXPLANATION:** Super blocks of the thermostat & heater are connected to the house. The house receives input from the temperature sensor & shares that data to the thermostat. The thermostat upon receiving the data analyses it and sends signal to the heater. The heater interprets the received command &, if necessary, increases/decreases or maintains the heating of the house. The meter connected to the heater calculates the cost of operation of the heater. A signal routing system calculates the temperature variation for analysis.
6. **Results:** The following project is done with the help of Scilab software. A control strategy is developed attached to obtain the temperature variation & cost of electricity of the house. The results show that as the outside temperature varies according to the climate & time so does the indoor temperature varies in accordance with the heat supplied by the heater. The continuous time system meter attached to the heater monitors & calculates the cost of operation & conveniently displays it in a graphical format. It is observed that the cost of operation keeps on increasing whilst the heater is on & functioning but it shows various slopes suggesting decreasing or increasing output which shows the control by thermostat. This concludes the modelling & analysis of the house.

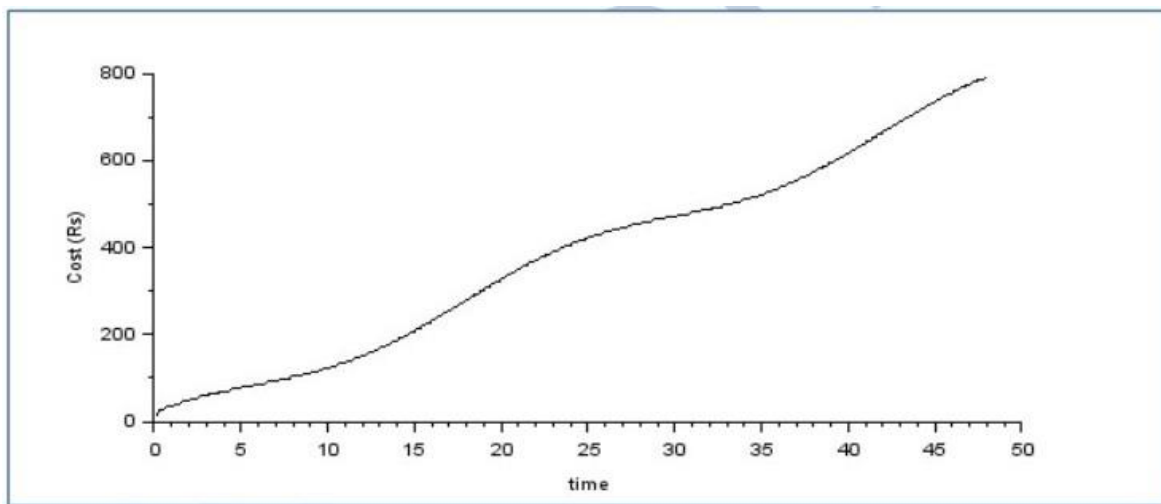

Chart -1: Cost of Heater

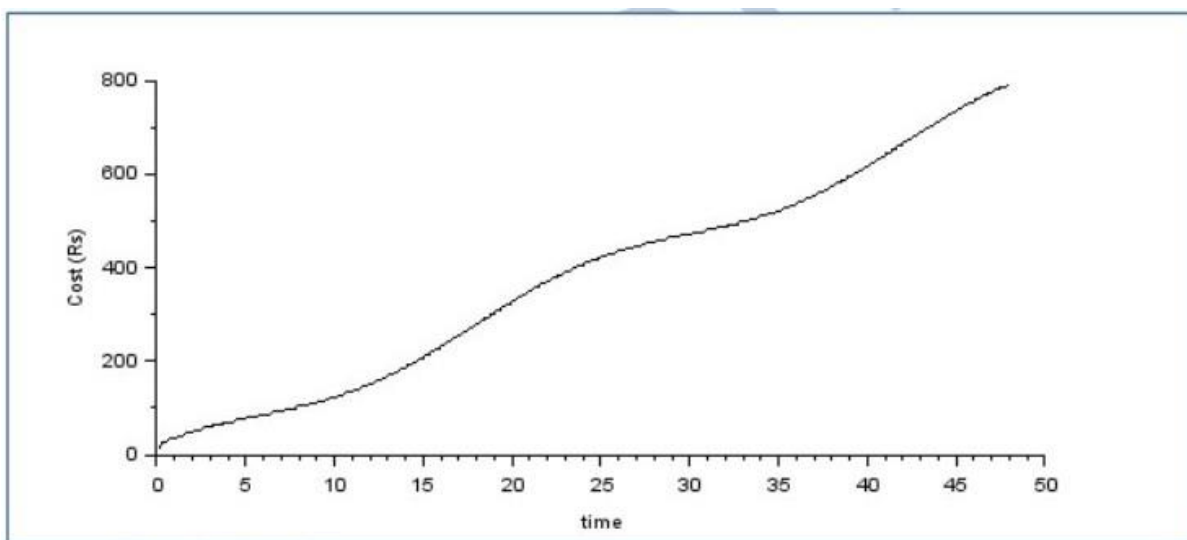

Chart -1: Temperature variation of the house.

7. **Future scope:** - To validate the software result we have plotted the graphs using theoretical calculations. Individuals can validate these results by doing experimental verification that is by building the actual model or by doing industrial projects related to Thermal modelling.
8. **Conclusion:** The following project sheds light upon the fundamental working system of how heating works in a house. Based upon the data calculated it can be concluded that the heating of the house is in fact dependent on the temperature variation of the surrounding climate. The thermostat successfully controls the Heater & provides utmost precision & in turn provides the comfort necessary. With the help of system meter & signal routing system, the heater output & cost deemed can be determined. All of this helps in understanding & improving the HVAC system of a house & can be further used in determining of similar systems in larger scale. The purpose of finding various thermal aspects of the house such as cost of heater, temperature variation has been successfully attained.

Acknowledgement:

1. Decibels Lab, Bangalore.
2. Dr. S.D. Dalvi (Project Guide, LTCE)

References:

1. **Thermal modelling of the building and its HVAC system using MATLAB/Simulink** "S. Karmacharya, G. Putrus, C. Underwood, K. Markamov, School of Computing, Engineering and Information Science 2School of the Built and Natural Environment Northumbria University Newcastle upon Tyne, UK"
2. **Modelling of thermal processes in apartment houses** "Sven Peets, Tõnis Peets and Eugen Kokin Institute of Engineering, Estonian University of Life Sciences, Fr. R. Kreutzwaldi 56, 51014 Tartu." Proc. Estonian Acad. Sci. Eng., 2006, 12, 1, 59–71
3. **MATHEMATICAL MODEL OF SELECTED OBJECT THERMAL PROPERTIES** "K. Peszynski, W. Szmyt, S. Wawrzyniak, D. Perczynski" 22nd International Conference Engineering Mechanics 2016 Svartika, Czech Republic, 9-12 May 2016
4. **Thermal performance modelling of residential house wall systems** "Fayez Aldawi, Firoz Alam, Abhijit Date, Mohammad Rasul; School of Aerospace, Mechanical and Manufacturing Engineering, RMIT University, Melbourne, 3083, Australia, School of Engineering and the Built Environment, Central Queensland University, Rockhampton QLD 4702, Australia" Science Direct Procedia Engineering 49 (2012) 161 – 168