

Vehicle Braking Distance Characterization using Different Brake Types

Sabry Allam¹, Fathy Nader², Khaled Abdelwahed³

¹Professor, Department of Automotive Engineering, Helwan University, Cairo, Egypt

²Researcher, Sehafa Technological College, El-Sehafa, Cairo, Egypt

³Assistant Professor, Department of Automotive Technology, Helwan University, Cairo, Egypt

Abstract – Braking distance refers to the distance a vehicle travels from the point where its brakes are fully applied to a complete stop. It is mainly affected by the original vehicle speed, the coefficient of friction between the tires and the road surface, the type of the used brake system, vehicle load, tire pressure, and road vertical grade.

In this research, theoretical and experimental characterization of the braking distances using conventional braking system, ABS, emergency braking systems are evaluated at different vehicle loads and speeds. The theoretical models are performed using Matlab Simulink, while the experimental works are done using a quarter car model, which is designed, manufactured, and built in the Lab.

It has been found that the vehicle braking distances (Ds) are inversely proportional to the brake oil pressure (the applied force) and friction coefficient, while they are direct proportional to the vehicle speeds and loads. It has found that the measured and predicted Ds are in a very good agreement at all operating conditions.

At constant load, Ds is decreased by 14% when the applied force is increased by 20%. At a vehicle speed of 100 km/hr, Ds is increased by 25% when its load varied from no load to full load. Ds is decreased about 12.5% by when the coefficient of friction is increased by 10%. Using ABS at 100 km/hr and full load, Ds is decreased about 35%, while using EBS with ABS at full load, Ds can be reduced about 25% comparing with the ABS alone.

Key Words: ABS, coefficient of friction, braking distance, Automatic Emergency Braking System.

1. INTRODUCTION

Driving a vehicle is not a challenge but to ensure safe driving is an issue. Therefore, car manufacturers and institutions are working to improve the safety on roads. Safe driving includes passive and active systems. Passive systems minimize passenger injury during a crash (seat belts, neck support etc.) where as active systems prevent crash such as antilock braking system (ABS) [1].

The braking in emergency situation in conventional vehicles causes the wheels to lock. This locking of brake reduces the friction between tires and road, as a result

driver loses the steering control of vehicle [2]. The anti-lock braking system detects the locking of wheel and releases brakes to avoid such situation. This operation results in improved longitudinal stability and steering control [3]. The ABS also tries to maximize the frictional forces between the tires and the road, consequently minimizing the braking distance.

Braking distance is applied as a significant basic parameter in e.g. calculations of stopping sight distance. A vehicle's braking distance depends on a number of factors pertaining to the vehicle, the road and the driver's behavior. The most important factors are; speed, coefficient of friction, braking behavior, braking system and condition, tyre condition and road's vertical grade.

All these factors affect braking distance to a greater or lesser extent depending on the actual conditions when decelerating. A general method for determining braking distance at different speeds, which is representative for the composition of cars, drivers and friction, requires knowledge of the significance of the individual factors for overall braking distance. The purpose of this study is to assess the braking behavior of nonprofessional drivers, including braking distances under different physical conditions [3]. The automatic braking is a technology for automobiles to sense an imminent collision with another vehicle, person or obstacle and to apply brakes to slow the vehicle without any driver input. Sensors are used to detect other vehicles or obstacles, these can be radar, video, infrared, laser, ultrasonic or other sensing technologies [4].

1.1 Disc Brake

There are two kinds of service brakes, that stop your vehicle while driving: disc and drum brakes. Disc brakes that shown in Figure 1 consist of; a brake rotor which is attached directly to the wheel. Hydraulic pressure from the master cylinder causes a caliper (which holds the brake pads just outside the rotor) to squeeze the brake pads on either side of the rotor. The friction between the pads and the rotor causes the vehicle to slow and stop.

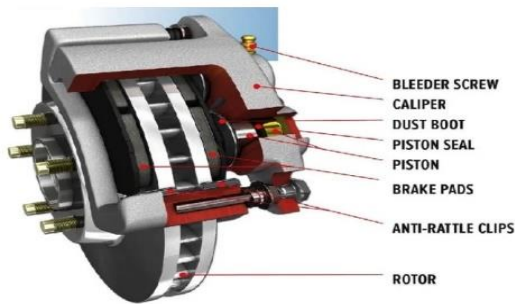

Figure (1) Disc brake system [6].

The braking force is generated by piston squeezing frictional material in both sides of the rotor/disc which is attached to the wheel. The U-shaped caliper is supported by stationary vehicle components such as the suspension system [5,6].

The disc brake systems are classified as; floating and fixed caliper. A floating caliper type is shown in figure (2). This type of brake uses only a single piston to squeeze the brake pad against the rotor [7].

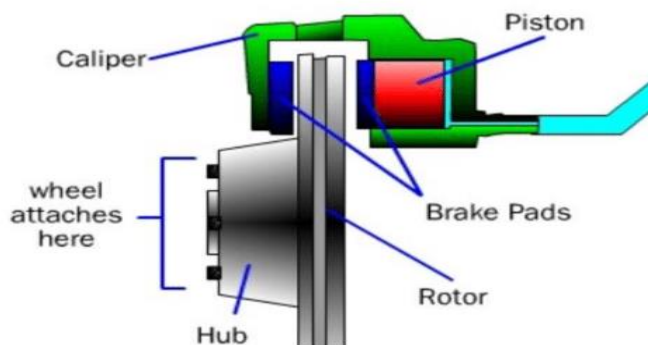

Figure (2) Floating caliper disc brake [7].

The reactive force shifts the caliper housing and presses the other brake pad against the rotor. Figure (2) shows the idea of operation of floating type disc brake, the brake fluid pushes the piston to the left when the brake is applied, so the piston pushes the inner pad and presses it against the disk, the sliding caliper housing reacts by shifting towards right pushing the left pad against the disc, in order to generate a frictional torque to slow or stop the rotor.

1.2 Anti-lock braking system

ABS (Anti-lock Braking System) is a braking system that ensures full control of the steering wheel by preventing the vehicle from locking the wheels in sudden braking situations in all road conditions and at all speeds. ABS system is developed to prevent the locking of the wheels on motor land vehicles. In the case of ABS braking, the change in the number of revolutions of each wheel is controlled by

an electronic control unit which is called Brake Control Module (BCM or EBCM). ABS is a system that does not lose the connection of the wheels with the steering wheel when the brake pedal is pressed. It stops the wheels by sending a command to the wheels with very short intervals, and after a very short time it sends the command again to deactivate squeezed brake calipers. This sequence state is repeated twenty times in a second. The aim is; when a car at high speed it cannot suddenly stops, it cannot stay where it is due to moment of inertia. So, it continues to slide forward suddenly. At this time, passengers inside the vehicle can even jump out of the windshield. However, ABS slows the wheels and stops the car in a controlled way. Figure (3) shows Location of wheel speed sensors, Master Cylinder, Control module in the vehicle [8].

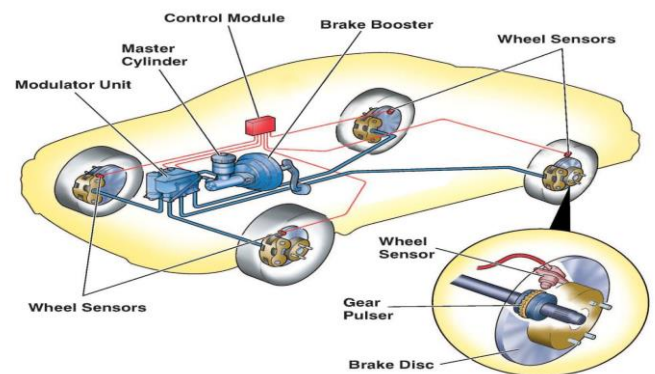

Figure (3) Location of wheel speed sensors, master cylinder, control module in the vehicle [8].

An antilock system can attain maximum frictional force and results minimum stopping distance. This objective of antilock systems however, is tempered by the need for vehicle stability and steerability. Stability The fundamental purpose of braking system to decelerating and stopping of the vehicle, maximum friction force may not be described in some cases like asphalt and ice (p-split) surface, such that significantly more braking force is obtainable on one side of the vehicle than on the other side. So when applying a full brake on both the sides will result in a yaw or skidding moment that will tend to pull the vehicle to the high friction side and results in vehicle instability. Here comes the concept of antilock system that maintains the slip both rear wheels at the same level and minimize two friction coefficient peaks, then lateral force is reasonably high though not maximized. This contributes to stability and an objective of antilock systems [8]. Figure (4) shows effect of Anti-lock Braking System.

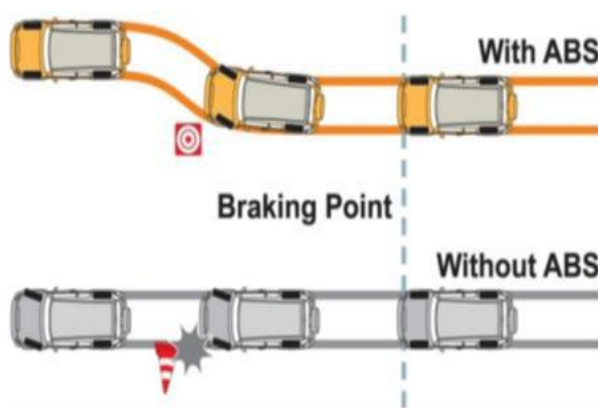

Figure (4) Effect of ABS [8]

1.3 Automatic Braking System

Automatic braking system uses an infra-red technology in a large sort of wireless applications and the most of the areas such as sensing and remote-control system. The electromagnetic spectrum is the infrared portion is spitted into three regions and they are close IR region, far IR region and middle IR regions. The wavelength of the regions and their applications are given. The close infrared region is 700 nm to 1400nm, fiber optic middle infrared sensor is 1400-3000nm and heat sensing infrared region is 3000nm to millimeter. For optical sensing and optical communication, icon optics technologies are utilized in the close to infrared region because the light-weight is a smaller amount complicated than RF once enforced as a supply of signal. Optical wireless communication is finished with IR information transmission for brief vary applications. The emergency braking system combination and with driver assistant system are used to slow down the automobile vehicle and potential warning before the collision. The research deals with the implementing of emergency braking using autotropic [9].

The results advised that several of those accidents were caused by basic cognitive process. Automatic braking system mix sensors technology with brake system to forestall high speed impact and number of the automated braking systems will stop collisions altogether however most of them are designed and placed for the luxurious high price vehicles. Since high-cost vehicles are additional doubtless to be fatal than affordable automatic braking systems will save lives and scale back the number of property harm that happens throughout an accident in traditional vehicles. a number of these systems use lasers others use radio detection and ranging and a few even use video information. The IR detector input is employed to work out if there is any objects gift within the path of the vehicle. The IR detector is placed before bumper; the system will then confirm the speed of the vehicle is larger than the speed of the thing before of it. A big speed of the vehicle could indicate that a collision is probably going to occur during which case the system is capable of

mechanically activating the brakes. The signal from the IR detector that is connected to the stepper motor through control unit which create the braking system to manage at this example. The speed detector senses the speed of the vehicle and stepper motor is activated depends on the speed of the vehicle. The braking is activated by programmed within the management unit. The stepper motor that drags the braking cable which is connected to the front and rear wheels at variable force. However, automatic brakes will save your life if you ever suffer from a short lapse in concentration. The idea of this project is price effective and might be used these in rider vehicle [10].

The work had an intense study to develop a new system. where driver may not apply the brake but the vehicle will able to stop or divert automatically due to obstacles. For the safety purpose and to avoid such unconditional accidents an automatic control braking system is introducing in the vehicles. Here a ranging sensor is used i.e. ultrasonic sensor which detect through the ultrasonic wave. Whenever a hindrance is recognized by the sensor, the ultrasonic sensor detects and reflect back to divert the route of the vehicles. In this study the vehicles will automatically divert and apply brake due to obstacle when the sensor senses the obstacle as shown in Figure (5). In this system an automatic braking and diverting system is designed in which the car will automatically reflect after received signal from the sensor [11]. In this study, ultrasonic sensor is used to model the automatic braking system. It enables to move the vehicle with less human driving focus. The interference is detected by the ultrasonic sensor. The servo motor functions as an actuator to process the feedback from the ultrasonic.

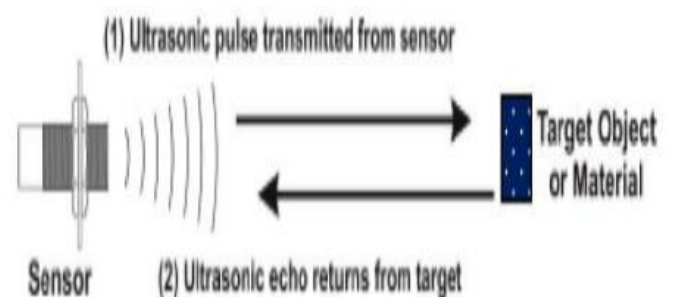

Figure (5) A schematic diagram of Ultrasound working principles in automatic braking [11].

2. LITERATURE REVIEW

M. Watany [12] presented a mathematical simulation of an ABS in MATLAB, which employs a quarter car vehicle's model undergoing a straight-line braking maneuver. The model also incorporates a hydraulic brake valve dynamics and road-tire interaction. The road-tire interaction model is given in the form of an empirical function (Magic

formula) describing the nonlinear relation between adhesion (rolling) coefficient and wheel slip. A Bang-Bang controller has been implemented with the above model for controlling wheel slip at given desired reference value. The braking performances in both assisted ABS mode and non-ABS mode have been evaluated by simulation. Simulated results of stopping distances were confirmed using a road test setup. The results indicate that the braking performance of automotive assisted ABS was improved significantly, the braking time advanced, and the stopping distance shorten consequently, the braking safety of vehicle can be improved.

The ultrasonic vehicle braking system involves an in front component of an automatic braking vehicle with an ultrasonic sensor generating and emitting the front of the ultrasonic wave at a certain distance in front of the vehicle was presented in [13]. Ultrasonic beneficiary likewise molded a vehicle's front area, getting an intelligent ultrasonic wave signal as an impression of the hindrance situated inside the separation determined. The wave was estimated to acquire the separation between the vehicles and the obstructions. On the other hand, Arduino is utilized to drive the servo engine based on location data to constrain the brake pedal to irregularly brake the vehicle to consequently brake the vehicle for safe braking.

The paper presented by Hemalatha B K, et, al., [14], comprises the use of Infrared sensors for obstacle detection with help of PIC microcontroller. This based on microcontroller technology for collecting data related to speed and transmitting it through a transceiver to a base station that analyzes the transmitted data and takes appropriate decisions Related to speed limit and control requirements.

N. V. Kumbhojkar, etc. al [15], presented the use of ultrasonic sensors with help of PIC microcontroller, transducers and servo motor braking mechanism. It is intended to use in vehicles where the drivers may not brake manually, but the speed of the vehicle can be reduced automatically due to the sensing of the obstacles.

Zhang, Lu [16] has designed technology of an Automatic Braking System in the Reversing Based on Electric Vacuum Booster. This system can avoid the collisions in the reserving and keep the vehicle in low uniform speed. This system is mainly involved in four major modules, the detecting module, MCU module, braking control module, and display module. He used the fuzzy PI controller to maintain the vehicle speed by EVB. If the real-time distance is in the dangerous range, the vehicle will immediately stop. In this system, ultrasonic sensors are used to measure distance. The result of the experiment shows the success rate is up to 95%. The process of vehicle braking is traveled between 0.15m and 0.25m. Advantages of this system, displays of real-time speed, real-time acceleration.

Jeyanthi R [17] has presented an advanced automatic braking system with sensor fusion concept. This technique allows for both detection and classification of objects. An ultrasonic sensor is used to measure the distance between vehicle and obstacle and, the capacitive sensor is used for classification of objects. The result shows he placed the system in a car whose braking system is controlled by a DC motor. He has tested the working of the system in a three-speed level operation specified above. The system responded by reducing the speed of the vehicle when the obstacle is placed at a variable distance from it. Also, the system disabled horn automatically and reduced speed automatically in restricted areas.

Vidyadhar M. [18] presented a system that can enhance the safety of the vehicle. This system depends on three parts, First, the anti-collision system using a laser beam and then using an ultrasonic sensor is implemented which gives better accuracy. This system gives the solution that can assist the driver by warning him about impending obstacle & approaching the vehicle that may lead to the collision, in addition to this they are also implementing & auto retarding system which helps in avoiding accidents. In this system ultrasonic sensor, motor driver and LCD are used. In addition to this, they have implemented an automatic wiper speed control which controls the speed of wiper based on the intensity of rainfall.

Firoz S. [19] presented an intelligent mechatronic braking system. The main target for this presented technology is, cars can run automatic braking due to obstacles when the sensor senses the obstacles. The braking circuit function is to break the car automatically after the received signal from the sensor. An intelligent mechatronic system includes an ultrasonic wave emitter provided on the front portion of a car producing and emitting ultrasonic waves frontward in a predetermined distance. The reflected wave (detected pulse) measured the distance between the obstacle and the vehicle. Then a microcontroller (ATMEGA32) is used to control the speed of the vehicle.

Shival D. [20] has designed and Development of Vehicle Anti-collision System using Electromagnet and Ultrasonic Sensors. The electromagnetic anti-collision device was Designed in order to avoid Vehicular Head to Head/Back collision that estimates the distance between the two vehicles running extreme traffic condition. An ultrasonic sensor used to find the rang distance between two vehicles moving and sends it to the ECU (electronic control unit) using these inputs if it finds the vehicle in the vicinity of the other it will automatically actuate the sensor strip for Electromagnetic Induction. A microcontroller (ATMEGA 16) responsible for received signals echo from the ultrasonic range finding the sensor.

T.U. An and Santhosh K. [21] presented an advanced accident avoidance system for automobiles. The complete

system model of the proposed system is divided into two main modules as first model Collision Avoidance System (CAS), another model Automated Accident Detection and Information system (AADIS). To avoid an early collision system, control the speed of the vehicle depends on the information such as the distance between two vehicles and the speed of the vehicle. In this system used IR sensors to detect the in front vehicles and ultrasonic sensors to detect adjacent vehicles.

T. P. Gawande [22] has proposed the technology of speed control system. he designed a module to control speed & automatic braking system in the vehicle. The main objective of this system to prevent the driver and passenger inside the vehicle from the accident and automatically inform about the hurdle in the path of the vehicle on displays through LED with the help different of sensors. The main components of this system are the electronic circuit such as the sensor, relay, control system, microcontroller, the signal transmitter, signal receiver and peripheral interface circuit (PIC). An ultrasonic sensor which consists of an ultrasonic transmitter and ultrasonic receiver used to detect the obstacle or hurdle and sent signals to control unit, then control unit processed this signal and sent suitable signals to a warning system to warn the driver.

C. Kuchimanchi [23] has proposed technology of collision warning with automatic braking system for Electric Cars. This system is used to reduce the speed of the vehicle and stop it when the distance between the driver's vehicle and the front vehicle became limited. Collision detection is done by using ultrasonic and stop indication using a flashing LED and LCD display. When an ultrasonic sensor detects the objects such as vehicle or pedestrian, it sends the signal to the microcontroller which sends the signal to the brake circuit. Brake circuit consists of the servo motor and a lever which connected to the brake pedal, when servo motor received the signal from microcontroller the arm of the servo motor rotates the brake, a pedal is actuated and the brake is applied, to ensure optimal braking force and minimum braking distance.

J. Lewis [24] has proposed technology of fabrication of an automated collision avoidance system using ultrasonic sensor. The main components of this system are the ultrasonic sensor transmitter, ultrasonic sensor receiver, the microcontroller (8051), pneumatic cylinder and solenoid valve. Operating Principle is depending on air is compressed in the range of 4 to 4.5 bars. An ultrasonic sensor is provided in the front-end portion of the vehicle. Emitter continuously sends ultrasonic waves and waits for it to return back. In case of an obstacle present in the path, the waves are reflected back to the device to be sensed by the detector. The time taken by ultrasonic waves to reflect back to the detector is computed to find the distance from

the obstacle. On a forecast of the crash, the microcontroller (8051) controls a buzzer to alarm the driver.

R. S. Krishnaveni [25] has described a system based on an intelligent vicinity adapter for automobiles. The main objective of this system is preventing accidents that frequently occur on highways and to reduce discomforts at the speed breaker and potholes. It consists of units such as an ultrasonic sensor unit, ATmega328 microcontroller unit, servo-motor, auto-clutch, and anti-lock brake system. The ultrasonic sensor is used for sensing obstacles, speed breaker, and potholes and sends signals to control the brake system. Where the ultrasonic sensor emits the ultrasonic waves from the transducer. The emitted waves are reflected back by any object present at the front of this vehicle. As soon as the wave is emitted, the sensor changes to receiver mode. So, it senses the obstacles such as human or vehicle at a range of 10m and it sends signals to the microcontroller. The microcontroller (ATmega328P) calculates the distance of the obstacle and controls the servo motor. It sends the signals as 0-degree position, 90-degree position or 180-degree position to the servo motor.

T. Kavatkar [26] has presented a design and analysis of intelligent braking system. The main components of this system are ultrasonic sensor transmitter, ultrasonic sensor receiver, speed sensor (RPM counter), microcontroller (Arduino Uno) and braking unit. An ultrasonic sensor detects an obstacle and calculate the distance between the vehicle and obstacle such as other vehicle or pedestrians and send the signal to the microcontroller, the microcontroller receives the signals from both of ultrasonic sensor which calculate the distance and speed sensor (RPM counter) which calculate the speed of the vehicle. If the driver hit the brake pedal in the right time, microcontroller send suitable signals to brake unit to activate it and reduce speed of vehicle and stop it. The microcontroller used in this system is Arduino Uno which includes a lot of inputs and outputs.

A.H. Ingle I [27] has proposed technology of an intelligent braking system. In this system, the author proposed the using of the ultrasonic sensor to control the speed of the vehicle and applying the brake automatically at real time. This system consists of an ultrasonic wave emitter and an ultrasonic wave receiver to calculate the distance between two vehicles and using of hall sensor to monitors the speed of the vehicle. This two information (distance between two vehicles and speed of vehicles) quantities are used by the control system to calculate the actions on both the accelerator and also the brake, thus to adjust the speed in order to maintain a safe distance to prevent accidents. It is done by sending signals to the microcontroller (ATMEGA8-16PI) which processed it, and then it calculates the safe braking distance and applied the brake automatically to preventing collision of the vehicle with pedestrians.

R. K. SINHA [28] has proposed technology of anti-lock and automatic braking systems. The objective of this system is to sense and prevent an imminent collision with another vehicle, person or obstacle by applying the brake. The braking is done by controlling the clutch and activate the braking circuit. The main components of this system are the microcontroller (Arduino Uno), hall sensor, ultrasonic sensor, motors, and anti-lock system mechanism. The sensors used in this system measured the distance between the driver's vehicle and another vehicle and speed of the driver's vehicle. Hall sensor is used to measure the speed of the driver's vehicle and the distance measured by an ultrasonic sensor. if the speed of driver's vehicle is above the set velocity for a predefined safety distance, the microcontroller sends suitable signals to the anti-lock braking system and an automatic braking circuit which include clutch and motor to reducing the speed of driver vehicle.

3. BRAKING DISTANCE ANALYSIS

3.1 Simulink Model of the Conventional Brake System

A one-quarter mathematical model for the conventional brake system was implemented using Matlab Simulink by mathematical equations.

Assuming the vehicle acceleration, a is constant and using V_i is the initial velocity, the final velocity V_f , t is travel time by car and D is the travel distance. By looking at the four principal equations in kinematics [11], theoretical final velocity is obtained by:

$$V_f = V_i + a \cdot t \quad (1)$$

The travelled distance D is obtained by:

$$D = V_i \cdot t + \frac{1}{2} \cdot a \cdot t^2 \quad (2)$$

The final velocity can be also obtained using:

$$V_f^2 = V_i^2 + 2 \cdot a \cdot D \quad (3)$$

By using equation (1), (2), and (3), the travel distance DT can be calculated as:

$$DT = \frac{(V_f^2 - V_i^2)}{2a} \quad (4)$$

The braking distance D_s (the distance traveled by car before braking directly) as the car eventually stops (V_f is zero) can be calculated as:

$$D_s = -\frac{V_i^2}{2a} \quad (5)$$

The vehicle acceleration, a

$$a = \frac{V_i^2}{2D_s} \quad (6)$$

The brake force generated at the contact interface F_b

$$F_b = n \cdot \mu \cdot P \cdot A \quad (7)$$

When the car is stopped, the braking force F_b equals the drag force F_d

$$F_b = F_d \quad (8)$$

$$n \cdot \mu \cdot P \cdot A = m \cdot a \quad (9)$$

By using equation (6) and (9) The braking distance D_s can be calculated as:

$$D_s = \frac{(mV^2)}{(2 \cdot \mu \cdot n \cdot P \cdot A)} \quad (10)$$

Where:

D_s = The braking distance (m)

m = Vehicle mass (kg)

V = Vehicle speed (m/sec)

μ = The friction coefficient

n = number of pad

P = The oil pressure in the brake system (N/m²)

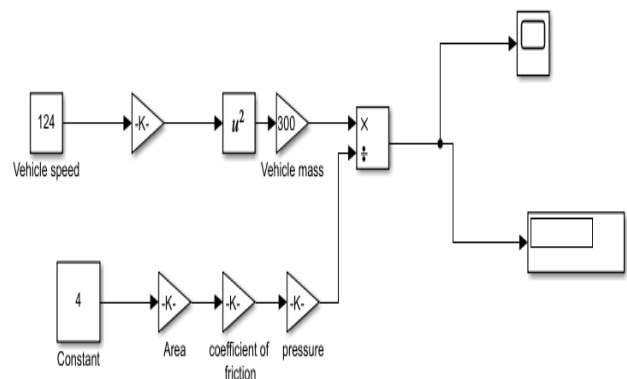

Figure (6) Simulink model of the conventional brake system

The effect of brake oil pressure on the braking distance of the vehicle is presented in Figure (7). It can be notice that the braking distance of the vehicle are decreased with increasing the brake oil pressure. with the increasing of the vehicle speed, the vehicle's braking distance increases at all applied pressures, and the braking distance reaches the lowest value at the highest pressure of 12 bar and the highest value at 8 bar.

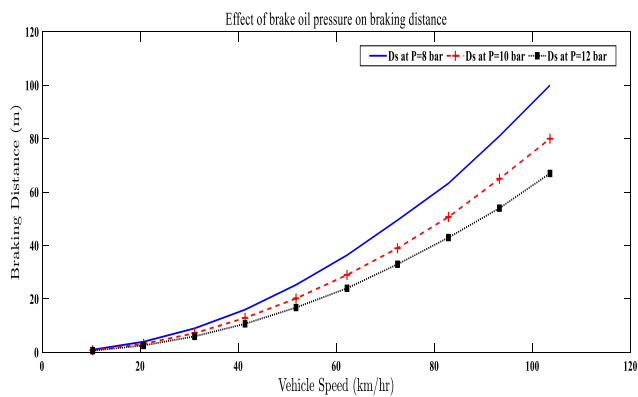

Figure (7) Variation of braking distance with vehicle speed at different brake oil pressure.

At a vehicle speed of 100 km/hr, by increasing the brake oil pressure from 8 bar to 10 bar, the vehicle's braking distance decreases about 20%, while its value reduced by 14% with the of the brake oil pressure from 10 bar to 12 bar.

The effect of vehicle load on the braking distance of the vehicle is presented in Figure (8). It can be seen that the braking distance of the vehicle are increased with increasing the vehicle load. When the vehicle speed increases, the vehicle's braking distance increases at all vehicle loads, and the braking distance reaches the highest value at the full load.

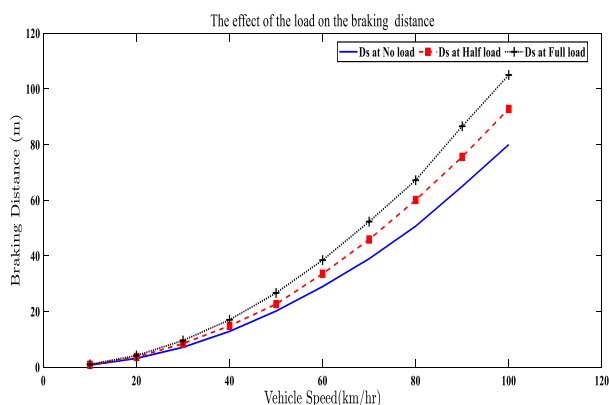

Figure (8) Variation of braking distance with vehicle speed at different vehicle load.

When the vehicle moves with a speed of 100 km/hr, the increase of the vehicle load from 0 to 50% load causes an increase on the braking distance by 12 % while, it increases by 25% at full load.

The effect of coefficient of friction on the braking distance of the vehicle is presented in Figure (9). It can be notice that the braking distance of the vehicle is decreased with increasing of the coefficient of friction, its values increase is

direct proportional with the vehicle speed at all coefficient of friction.

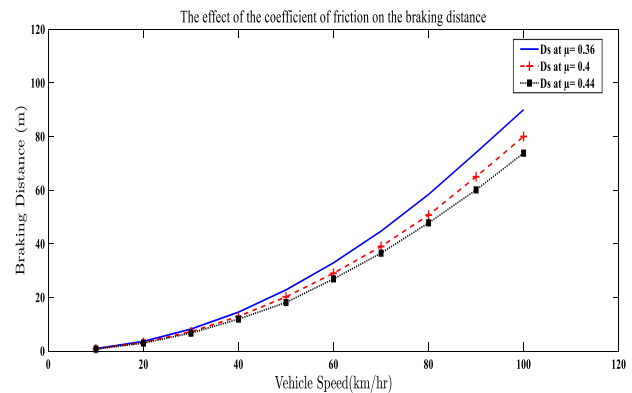

Figure (9) Variation of braking distance with vehicle speed at different coefficient of friction.

At a vehicle speed of 100 km/hr, the increase of the coefficient of friction from 0.36 to 0.4 causes a decrease in the braking distance by 12.7 % and the increase of the coefficient of friction from 0.4 to 0.45 causes a decrease on the braking distance by 11.4%.

3.2 Simulink model of an Anti-Lock Brake System

A one-quarter mathematical model for the ABS system was implemented using Matlab Simulink by mathematical equations that control operation of ABS system, this model has been created in next steps: Considered a vehicle moving in a straight direction under braking conditions figure (10) show vehicle model, write the equations of equilibrium for the horizontal direction as [29]:

$$F_f = F_i \quad (11)$$

Where F_f the friction force between wheel and ground and F_i the inertial force of the vehicle. Write the equations of equilibrium for vertical direction as:

$$N = W \quad (12)$$

where; N is normal force (road reaction) and W is vehicle weight. Write the expressions of the friction force as:

$$F_f = \mu \times N \quad (13)$$

where; μ the friction coefficient between wheel and road. The vehicle's weight is defined as:

$$W = mv \times g \quad (14)$$

By substituting equation (12) and (14) in equation (13) gives the expression of the friction force as:

$$F_f = \mu \times mv \times g \quad (15)$$

where; m_v is the total vehicle mass and g is the gravitational acceleration

The inertia force that product between the vehicle mass m_v and vehicle acceleration a_v as:

$$F_i = m_v \times a_v = m_v \times \frac{dv}{dt} \quad (16)$$

From equations (1), (5) and (6) the vehicle acceleration can be also calculated as:

$$\frac{dv}{dt} = \frac{1}{m_v} \times \mu \times g \times m_v \quad (17)$$

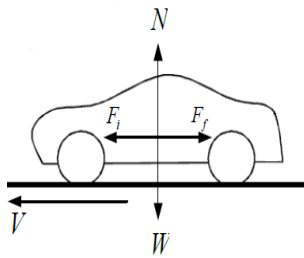

Figure (10) Vehicle model.

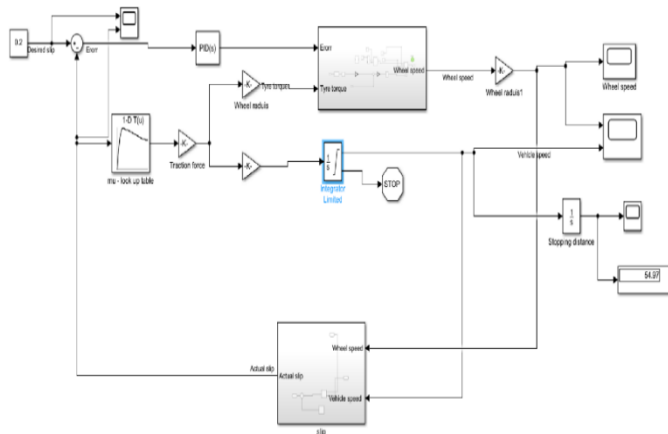

Figure (11) Simulink model of ABS system.

The effect of vehicle load on the simulated vehicle braking distance with the using of ABS is presented in Figure (12).

This result shows that the braking distance of the vehicle is directly proportional to the vehicle speed and are slightly increase the vehicle load.

At 100 km/hr, the braking distance increases by 3 % with the increasing of vehicle load from 0 to 50%, and 5.5% when it reaches full load.

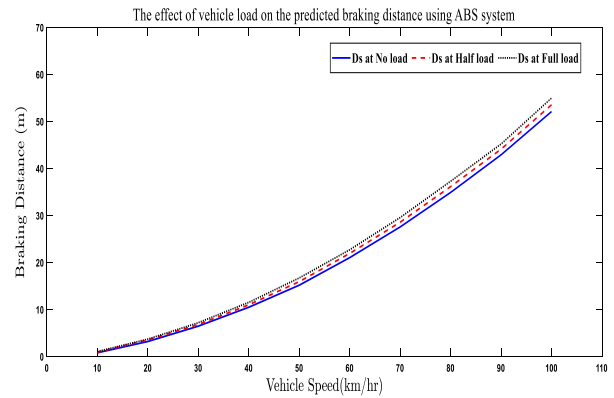

Figure (12). The effect of vehicle load on the predicted braking distance using ABS system.

The effect of braking system type and loads on braking distances are illustrated and presented in Figure (13).

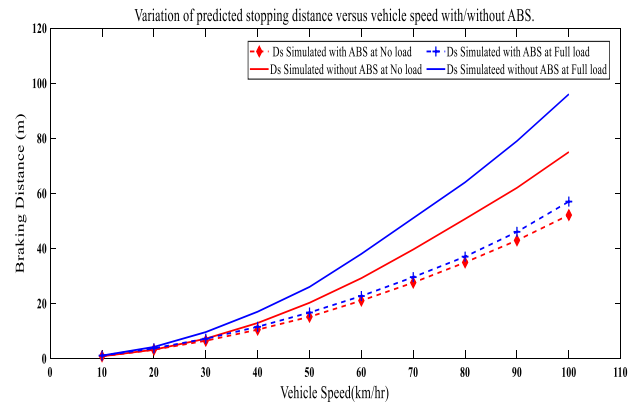

Figure (13) Variation of predicted braking distance versus vehicle speed with/without ABS.

As can be seen from the results, with the using of the ABS system at 100 km/hr, the braking distance is reduced by almost 30% without load and almost 43%, at full load.

4. TEST RIG AND MEASURING PROCEDURE

The test rig as shown in Figure (14) consists of mechanical components, electronic components, and the control unit. The mechanical components of the test rig are the disc brake, brake pedal, master cylinder, brake booster, solenoids valves, hydraulic pump, and an electric motor.

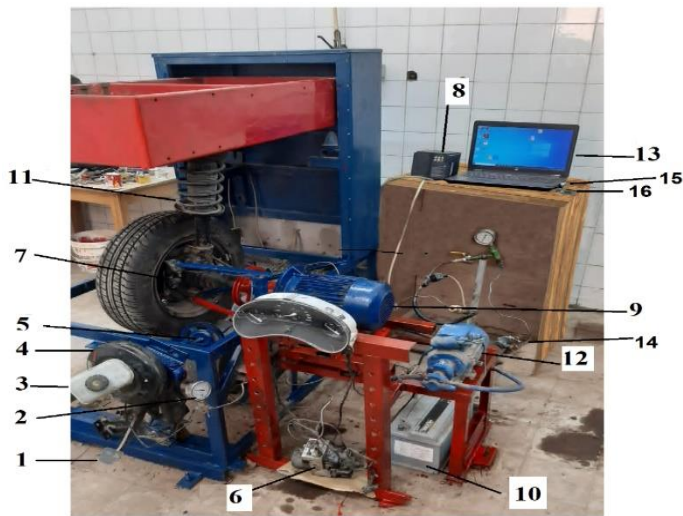

Figure (14) Main components of the test rig.

1- Brake pedal 2- Pressure gauge 3- Master cylinder 4- Brake booster 5- Circular handle 6- ABS unit. 7- Disc brake 8-Invertar 9- A.C motor 10- Battery 11-Suspension system 12- Electric pump 13- Computer. 14- Solenoid valve 15- Ultrasonic sensor 16- Arduino Uno Microcontroller.

A drum brake test rig is designed to provide the necessary rotational speed and applied pressure to the real braking applications. A brake pedal is used to transfer braking power from the driver's foot to the main cylinder and then to the wheel's cylinders, and it is also used to enlarge the braking force by an appropriate proportion. Solenoid valves are used to control the direction and pressure of brake fluid. Two types of solenoid valves are used, one solenoid valve is normally open, which is installed after brake pedal, another solenoid valve is normally closed, which is installed after the electric pump.

The electric pump is used to pump the brake fluid with the appropriate amount and pressure to stop rotation of disc brake, it operating over pressure 30 bar and the maximum volume flow rate is 0.25 L/sec.

An electric motor is connected to a disc brake by a suitable rod, which is rotating the drum brake by variable speeds, electric motor capacity is 5 HP.

As shown in Figure (14) and Figure (15), the electronic components used in the test rig are an Arduino Uno board, Ultrasonic sensor, and an electric relay. An Arduino Uno board of a microcontroller which used to receive signals from ultrasonic sensor and process it, then send signals to electric relays.

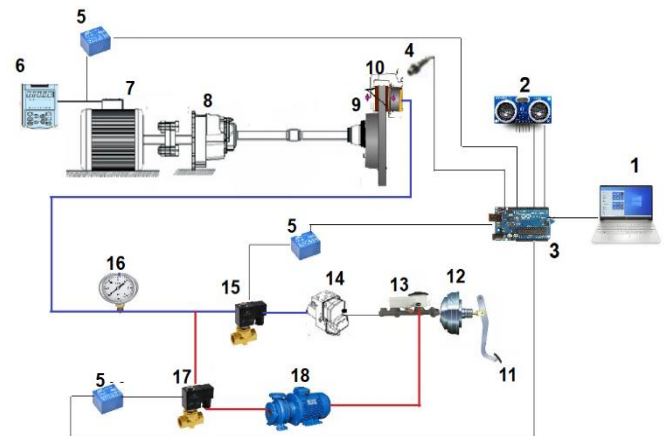

Figure (15) A schematic diagram of the test rig

1- Computer 2- Ultrasonic sensor 3- Arduino Uno Microcontroller 4- ABS sensor 5- Electric relay 6- Inverter. 7- A.C motor 8- Gearbox 9- Rotor/disc 10- Floating caliper 11- Brake pedal 12- Brake booster 13- Master cylinder 14- ABS unit 15- Solenoid valve normal open 16- Pressure gauge 17- Solenoid valve normal closed 18- Electric pump.

The sensor uses Input/output trigger for $10\mu\text{s}$ high-level signal, it automatically sends eight 40 kHz and detects for pulse signal and note down the time taken for waves to bounce back.

Test distance = travel time the \times velocity of sound. Knowing the speed of sound, the sensor determines the distance of the target and sets its outputs accordingly. It provides a range of 2 – 450 cm non-contact measurement function, the ranging accuracy can reach to 3 mm [30].

An electronic relay acts as a switch which is turned on and off using a signal. It is controlled through the digital I / O port, such as solenoid valves, lamps, motors, and other high current or high voltage devices. It used to control open or closed solenoids valves by signals from the microcontroller. To perform the measurements for different distances, Senix ultrasonic (RS232) sensors are used, which provides a measurement rang of 4 – 1500 cm of non-contact measurement function.

4.1 Automatic Barking Control Strategy

This system consists of two ultrasonic transducers as distance measurement sensors, kit of an electronic control unit to manage the signal input and output of sensor, hydraulic circuit, two solenoid control valves (one normally closed while the other is normally opened).

Ultrasonic sensor is operated all the time during driving producing ultrasonic transmitted sound waves, when these waves found an obstacle (vehicles or human) within a certain distance, the sound wave is reflected, the ultra-

sonic emitter sends signals to the microcontroller, which processes it. Figure (16) shows a schematic diagram of the control program.

If the measured distance between the obstacle and the vehicle is less than the desired distance which can be adjusted, the control unit sends a signal to activate the electronic relay to open the solenoid valve normally closed and closed the solenoid valve normally open, and stop the electric motor.

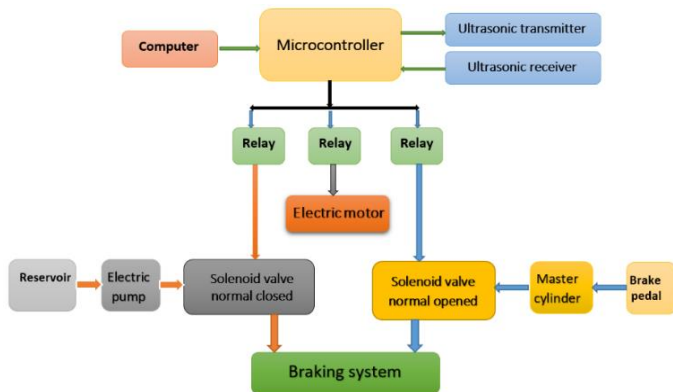

Figure (16) Block diagram of normal (blue) and/or automatic (red) braking system working methodologies.

The hydraulic pump draws the hydraulic oil from the reservoir and presses the fluid in the pipes to the disc brake piston which push the disc shoes and stop the vehicle.

After braking the vehicle, the activated solenoid valves return to their original positions and the hydraulic oil go back normally to reservoir. Figure (16) shows a schematic diagram of the control program.

5. RESULTS AND DISCUSSION

Braking performance reflects the capacity at which the vehicle stops in a short time and maintains movement stability. The approximate braking time is the amount of time the vehicle takes to reach a complete stop after applying brakes and the braking distance is the distance required for a vehicle that moves at a specific speed to reach full stop after the brake is activated so, the braking time and braking distance are an important indicator to evaluate braking performance. In this paper, complete comparison between predicted and measured braking distance are analysis.

In order to design and implement test rig, the braking distance of the car was studied and analyzed, and this was tested on the conventional brake system and the anti-lock brake system, and the following is a presentation of the results.

The measured and predicted braking distance using a conventional brake system at different vehicle loads are presented in Figure (17). The results show that the simulation agrees well with the measured result. The maximum difference between the measured and predicted results at 72 km/hr is 3% at full load.

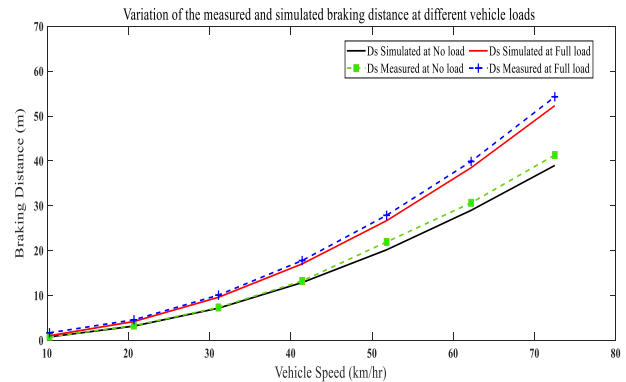

Figure (17) Measured and simulated braking distance versus vehicle speed at different vehicle loads of the conventional brake system.

The measured and simulated braking distance for vehicle with ABS system is presented in Figure (18).

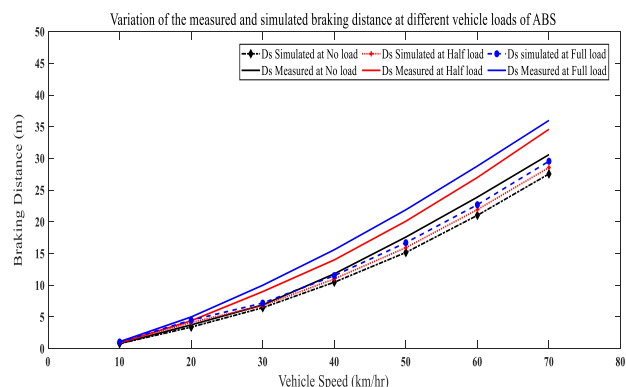

Figure (18) Measured and simulated braking distance versus the vehicle speed at different loads using ABS.

It can be notice that there is a slight increase in the value of the measured than the simulated braking distance, eps. at high speeds.

The measured braking distance of the conventional brake system and ABS is presented in Figure (19). It can be seen that the measured braking distances are slightly higher than the simulated results. At vehicle speed of 72 km/hr, the results show that there are 5 % in case of no load, 8 % at half vehicle load and 9.8 % at full vehicle load.

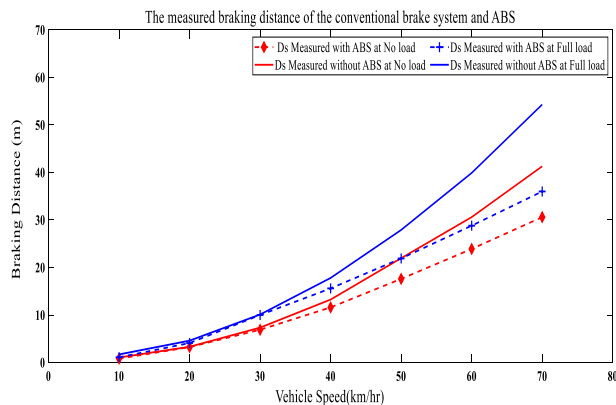

Figure (19) Measured braking distance using the conventional brake and ABS.

To evaluate the emergency brake system performance, the measured braking time or braking time has been measured at different distances. At each distance, the braking time of the vehicle was measured at five different speeds. The measured braking distance or braking time has been measured to compare between the measured and predicted braking time. The measured and calculated braking distance is presented in Figure (20). It can be notice, with the using of the ABS instead of the conventional braking system at 72 km/hr, reduces the braking distances by about 25% without load and 35% at full loads.

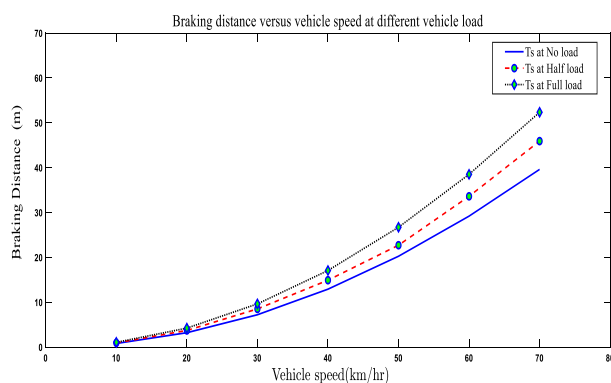

Figure (20) The measured braking distance of the automatic emergency braking system.

The measurements were performed at three distances between the system and an obstacle. These distances are 5, 10 and 15 meters. The braking time is measured at four different vehicle speeds; these speeds are 30, 50, 70, 90, and 110Km/hr. The measured braking distance at different loads are presented in Figure (20). The results show that there is an increase in the measured braking time with increase vehicle speed at different loads. At a vehicle speed of 72 km/hr, the braking distance increase by 15%, and 30% when the vehicle load varied from 0 to 50% and 100% respectively.

6. CONCLISIONS

The main ABS conclusions from the present study can be summarized in the following points:

- At constant load, the measured braking distance of the vehicle are reduced with increasing of the brake oil pressure. With the increasing of the vehicle speed, the vehicle’s braking distance increases at all pressures. At a vehicle speed of 100 km/hr, by increasing the brake oil pressure from 10 bar to 12 bar, the vehicle’s braking distance decreases about 14%.
- The measured and predicted Ds are in a very good agreement at all operating conditions.
- The vehicle braking distance are increased with increasing of its load. When the vehicle speed increases its braking distance increases at all vehicle loads. At a vehicle speed of 100 km/hr, the increase of the vehicle load from no load to full load causes an increases in the braking distance by 25 %.
- The braking distance of the vehicle are increased with increasing the value of the coefficient of friction. At vehicle speed of 100 km/hr, the increase of the coefficient of friction from 0.36 to 0.4 causes a decreases in the braking distance by 12.7 %.
- By using the ABS instead of the conventional braking system at a vehicle speed of 72 km/hr, reduces the braking distances by about 25% without load and 35% at full loads.
- Using the ABS, there is a good agreement between the measured and simulated braking distance at different speeds and loads.
- Using the emergency braking system (EBS) at 72 Km/hr and full reduced the stopping distance about 20% comparing with the ABS.

REFERENCES

- [1]. Bosserdt, P. I. "ANTI-LOCK BRAKE SYSTEM." Youth and science: Collection of materials of the VII All-Russian scientific and technical conference of students, graduate students and young scientists, dedicated to. 2011.
- [2]. Mohan, S. "Design and Development of an Improved Anti-Lock Braking System for Two-Wheelers." (2011).
- [3]. Samuel John (0418571X) PhD the-sis"Development of Nonlinear Real-Time Intelligent Controllers for Anti-lock Braking Systems (ABS)"
- [4]. M. Omae, T. Ogitsu, N. Honma, and K. Usami, "Automatic driving control for passing through

- intersection without stopping," Int. J. Intell. Transp. Syst. Res., vol. 8, no. 3, pp. 201–210, 2010.
- [5]. Sushil Kumar, Vishal Kumar, Automatic Emergency Braking System International Journal of Research in Science & Engineering, e-ISSN: 2394-8299, Volume: 1 Issue: 3 pages 93-96, 2017.
- [6]. <https://www.lesschwab.com/article/complete-guide-to-disc-brakes-and-drum-brakes.html>
- [7]. Dineshkumar C, Subramanian M "Automotive braking system for passenger vehicle to enhance safety". International Journal of Pure and Applied Mathematics Volume 117 No. 20 2017, 1011-1020 ISSN: 1311-8080 ISSN: 1314-3395 (on-line version). (2018).
- [8]. K. M. S. V. M. J.V.Sai Ram, G.Pavanth, B.Jagadeep ,Dr. B.Raghu Kumar, "Automatic Braking System Using Ultrasonic Sensor," International Journal of Innovative Science and Research Technology vol. 2, pp. 398-404, 2017.
- [9]. Halderman, J.D.: Automotive Brake system: Prentice Hall, Inc, NJ, USA,1996.
- [10]. BOSCH Automobile Hand book: 4th edition, October,1996.
- [11]. Mohamed Watany," Performance of a Road Vehicle with Hydraulic Brake Systems Using Slip Control Strategy" American Journal of Vehicle Design, (1), pp 7-18, 2014.
- [12]. Swastik Pradhan, 2Rama Seshu. Y, 2Jitesh Nagaraj. J. Automatic braking system. Journal of Emerging Technologies and Innovative Research, Volume 5, Issue 12 ,2018.
- [13]. Hemalatha B K, P Pooja, ChaithraM,MeghaS,Rakshitha R.T "Automatic Braking System for Automobiles Using IR Sensor" (IJAREIE) International Journal of Advanced Research in Electrical,Electronics and Instrumentation Engineering(An ISO 3297: 2007.
- [14]. NishadVivekKumbhojkar& ChaitanyaAvadhutchintanKuber "Ultrasonic Automatic Braking System For Forward Collision Avoidance With Accelerator Pedal Disengagement Mechanism", International journal & magazine of engineering, technology, management and research registrar of Newspapers of India(RNI) Regd No: APENG/47294/2011.
- [15]. Lu, Yan, Piao, & Zhang, Lu, S., Yan, B., Piao, C. H., & Zhang, Q. : An Automatic Braking System in the Reversing Based on Electric Vacuum Booster: Advanced Materials Research, 580, 360–364, <https://doi.org/10.4028/www.scientific.net/AMR.580.360>, 2012.
- [16]. Jeyanthi, Jeyanthi, R. : Automatic braking system with sensor fusion concept 1: 4(June), 23–27, 2012.
- [17]. Mr. Vidyadhar M, Mr. M Upendar reddy, Mr. Vidhyapathi C M, Mr. Dhanabal R, "Anti-collision and auto retarding system along with a wiper speed control during rains using MPS 430 microcontroller", International Journal of Engineering and Technology (IJET),2013.
- [18]. Sairam, Suresh, Hemanth, & Krishna, Sairam, G. V, Suresh, B., Hemanth, C. H. S., & Krishna, K. : Intelligent Mechatronic Braking System:, 3(4), 3–8, 2013.
- [19]. Dubey & Ansari, Dubey, S., & Ansari, A. W. : Design and Development of Vehicle anti-collision System using Electromagnet and Ultrasonic Sensors:, (1), 80–83,2013.
- [20]. Kumar & Mrudula, Kumar, T. U. A. S., & Mrudula, J. : Advanced Accident Avoidance System for Automobiles:, 6(2), 79–83, 2013.
- [21]. Gawande, Gavhale, Zariye, & Ritpurkar, Gawande, G. P., Gavhale, S. V, Zariye, I. A., & Ritpurkar, S. P. : Review of Speed Control and Automatic Braking System:, 3(2), 474–477, 2014.
- [22]. Thakur & Thakare. Thakur, D., & Thakare, A. P. : A Review on Implementation of FPGA for Automatic Reverse Braking System:, 4(1), 2013–2015.
- [23]. Lewis, Karthik, Lobo, Valder, & Rijesh, Lewis, J., Karthik, B. M., Lobo, J. M., Valder, J., & Rijesh, M. : Fabrication of an Automated Collision Avoidance System Using Ultrasonic Sensor :, 6, 97–101. <https://doi.org/10.59/c.jmea.201601.18,2016>.
- [24]. Scholar. Scholar, U. G. (2016): Intelligent vicinity adapter for automobiles: 1, 230–236, 2016.
- [25]. Kavatkar, Salvi, & Rahate. Kavatkar, T., Salvi, H., & Rahate, M. : Design and Analysis of Intelligent Braking System:, 5(1), 119–131,2017.
- [26]. Ingle, Bambal, & Shobhane, Ingle, A. H., Bambal, R. K., & Shobhane, S.: Intelligent Braking System: International Journal of Research In Science & Engineering, 2017.
- [27]. Uikey & Singh, Uikey, S., & Singh, R. M. : ANTI-LOCK AND AUTOMATIC BRAKING SYSTEMS:, (3), 68–71,2017.

- [28]. M. S. B. SAHRI, "ULTRASONIC CAR BRAKING SYSTEM " UNIVERSITI MALAYSIA PAHANG, pp. 1-24, 2016.
- [29]. A. P. Blancas, M. Eduardo, L. Lopez, R. M. Caporal, and R. O. Flores, "Simulation of the ABS Braking System Behavior in Critical Faults," no. November, 2019, doi: 10.21275/ART20202369.
- [30]. Hamdy. Abo el daheb, "ASSESSMENT AND DEVELOPMENT OF AN INTELLIGENT BRAKING SYSTEM WITH ITS EDUCATION APPLICATIONS" UNIVERSITI HELWAN, Master Thesis, 2019.

BIOGRAPHIES



Sabry Allam, is a Professor of Automotive Engineering at Helwan University in Egypt. He is a previous Dean of the Faculty of Technology and Education, Helwan University, Cairo, Egypt. He has more than 100 research paper in various automotive engineering research topics.



Fathy Nader is an Instructor at Industrial Technical Institute in El Sehafa, Technological College of Sehafa, Ministry of Higher Education in Egypt from 2012 till now. He received M.Sc. in Automotive and Tractors Technology 2017.



Khaled Abdelwahed is an Assistant Professor at Automotive Technology Department, Helwan University. He received his B.Sc. (1990) and M.Sc. from Eindhoven University of Technology (The Netherlands, 1997). In 2018 he received his Ph.D. in Automotive Technology from Faculty of Industrial Education, Helwan University, Cairo -Egypt. His research interest includes Auto. Technology and Teaching Methods in Auto. Technology.