

DYNAMICS OF AN OSCILLATOR FOR SINUSOIDAL INPUT

Pathan Shamsheerly Khan¹, B. Purushotham², B. Vishwanath³, A. Manaswini⁴

^{1,3,4}Student, Department of Biomedical Engineering, University College of Engineering, Osmania University, Telangana, India

²Student, Department of Electronics and Communication Engineering, Mvsr College of Engg, Telangana, India

Abstract: An oscillator is the most basic element for generating sources of signals. It generates sinusoidal signals of required frequency and amplitude. It is the basic instrument used in electrical and electronic measurements in laboratories as well as researches. The applications include frequency modulation and amplitude modulation. Although we speak of an oscillator, as a generation of sinusoidal signal, it does not store any energy. The function of an oscillator is exactly reverse of that of a rectifier and therefore sometimes it is also called as inverter. Although an alternator also called as AC generator generates sinusoidal power of 50HZ but it cannot be called as an oscillator. This review paper gives a detailed idea of different types of oscillators present, their working principle, their frequency of oscillations, their gains with neat labelled diagrams.

Keywords: clapp oscillator, Hartley oscillator, field effect transistor, bipolar junction transistor, crystal oscillator, rochelle salt, tourmaline.

1. INTRODUCTION:

Oscillators may be broadly divided into 2 categories. They are harmonic oscillators and relaxation oscillators. Both types can include active devices such as bipolar junction transistors and field effective transistors and passive components such as resistors inductors and capacitors. Energy always travels in one direction from the active to the passive component in harmonic oscillators. The energy is exchanged between the active and passive components in a relaxation oscillator, on the other hand. The feedback path determines the frequency of oscillations in a harmonic oscillator. The frequency of relaxation oscillators, on the other hand, is determined by time constants, particularly the charge and discharge time constants during energy exchange. Harmonic oscillators can produce low-distortion sinusoidal waveforms, but relaxation oscillators can only produce non-sinusoidal waveforms as auto square or triangle. In this study, harmonic oscillators will be discussed.

Oscillators have many advantages over alternators. Some of them are listed below

1. The oscillators are portable and cheap in cost
2. Frequency of oscillation may be conveniently varied.

3. Voltages free from harmonics as well as not free with harmonics can be generated by sinusoidal oscillators and relaxation oscillators respectively.

4. An oscillator is a non- rotating device, so there is no damage to inner parts and hence longer life.

5. Operation of an oscillator is noise free, as there are no rotating parts in it.

6. High Operation frequency - due to absence of rotating parts, there is no wastage of energy produces that tends to reduction of friction.

1.1 LITERATURE SURVEY

Ahmed m Soliman(1): This paper reviews oscillators of 2 integrated loop quadrature. The main contribution of this review is it gives the information about the types of quadrature oscillators and their functioning.

Gyorgy Csaba, Wolfgang porod(2): This review paper gives review of coupled oscillators of dynamically high complex systems. The main contribution of the paper is acknowledging with the biological oscillators and the characteristics that might enable effective computing.

1.2 Proposed work

CLASSIFICATION OF OSCILLATORS

The oscillators according to operating frequency can be classified as follows

TYPES OF OSCILLATORS	APPROXIMATE FREQUENCY RANGE
Audio frequency oscillators	20Hz -20kHz
radio frequencies oscillators	20kHz -30MHz
very low frequency oscillators	15-100kHz
low frequency oscillators	100-500kHz
broadcast oscillators	500kHz-1.5MHz
video frequency oscillators	0-5MHz
High frequency oscillator	1.5-30MHz
very high frequency oscillators	30-300MHz
ultra-high frequency oscillators	300-3000MHz
microwave oscillators	Beyond 3GHz (3000 MHz)

Oscillators can also be divided into groups based on the ingredients they include. They are RC oscillators and LC oscillators. The combination of RC and LC oscillators are said to be transistor oscillators.

RC oscillators uses resistors and capacitors whereas LC oscillators uses inductors and capacitors as their phase shifting circuits. The examples of LC oscillator are tuned collector oscillator, tuned base oscillator, Colpitts oscillator, Hartley oscillator, clapp oscillator, crystal oscillator etc.

GENERAL FORM OF AN LC OSCILLATOR

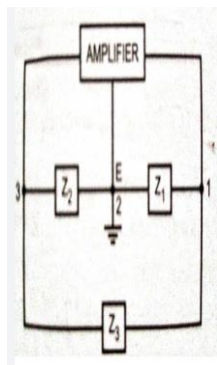

Fig 1 LC oscillator

In the general form of an oscillator depicted in the above figure, any of the active devices such as vacuum tube, bipolar junction transistor, field effect transistor or an operational amplifier may be used in the amplified section, Z1, Z2, Z3, are the reactive elements constituting the feedback phase shifting circuit which resolve the frequency of oscillation. Here, Z1 and Z2 serve as an AC voltage divider circuit for the output voltage and feedback signal. Thus, the voltage across Z2 is the feedback signal. The equivalent circuit is drawn just right to the first diagram with the following 2 assumptions

1. h_{re} of transistor is negligibly small and, therefore, the feedback source h_{re}.V_{out} is negligible.
2. h_{re} of the transistor is very small i.e., the output resistance h_{oe} is very large and, therefore, 1/h_{oe} is omitted from the equivalent circuit.

The general form of an LC oscillator is as follows

$$HfeZ_1Z_2 / Hie(Z_1+Z_2+Z_3) + Z_1Z_2 + Z_2Z_3 = -1$$

(OR)

$$Hie(Z_1+Z_2+Z_3) + Z_1Z_2(1+Hfe) + Z_2Z_3 = 0$$

DIFFERENT TYPES OF LC OSCILLATORS AND THEIR WORKING

1. TUNED COLLECTOR OSCILLATOR

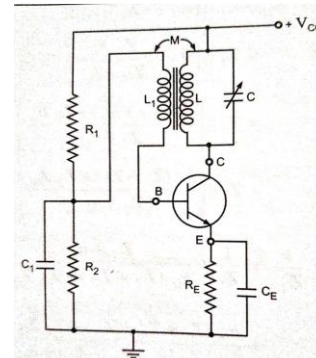

Fig 2 tuned collector oscillator

WORKING: when the supply VCC is switched on, a transient hold on current is caused in the tuned LC circuit. It is due to rise of collector current to its quiescent value. This transient current initiate natural oscillations in the tank circuit. These natural oscillations induce some voltage into L1 by mutual induction which causes simultaneous change in base current. These variations in base current are amplified beta times and appear in the collector circuit. A part of this amplified energy is used to meet the losses that occur in the tank circuit and the rest is radiated out in the form of electromagnetic waves. The turn ratio of L and L1 is determined by the total losses. Higher is a turn ratio lesser is the feedback voltage applied and vice versa. The frequency of oscillation that is the frequency at which bark Hausen criterion is satisfied differs from the resonant frequency of the tuned circuit. The reason behind this is the loading of the transformer secondary to some extent.

The frequency of oscillation is given as $f = 1/2\pi \sqrt{L \cdot C}$.

L=INDUCTANCE OF COIL

C=CAPACITANCE

TUNED DRAIN OSCILLATOR

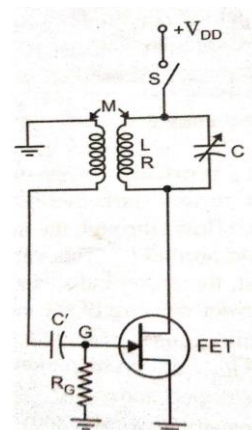

Tuned Drain oscillator is similar to the tuned collector oscillator, discussed in above section, the basic circuit is given in above figure. Because of its high input resistance and high voltage gain a field effect transistor can be used instead of a bipolar junction transistor to make the oscillator circuit.

FRANKLIN OSCILLATOR

The Franklin oscillator is shown in below figure. Here 2 common emitter amplifier stages are employed to provide 360 degrees phase shift from input to output. The values of the different components used in the circuit are chosen to provide overall loop gain of the two stages slightly greater than unity.

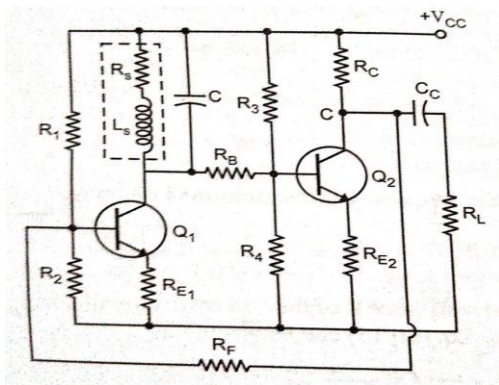

Fig 4 Franklin oscillator

COLPITS OSCILLATOR

The Colpitts oscillator is widely and commonly used commercial oscillator which generates sinusoidal signals up to 100 MHz. The basic Circuit of the transistorized Colpitts oscillator is shown in the below figure. It consists of single stage inverting amplifier and LC phase shift network. The two series capacitors C1 and C2 forms the potential divider circuit which provides feedback voltage. And the capacitance developed across the capacitor C2 provide feedback required for sustained sinusoidal oscillations. The parallel combination of the emitter resistors RE and the capacitor CE along with resistors R1 and resistor R2 provides a stabilized self-bias.

WORKING When the collector supply voltage VCC is turned on, the first step of work begins. The capacitors C1 and C2 are charged when the VCC is turned on. Oscillations are created when these capacitors C1 and C2 discharge through the coil.

The oscillations across capacitor C2 are transferred to the base emitter junction in the collector circuit and amplified. Commonly, the amplified output in the collector circuit is of the exact same frequency as that of the oscillatory circuit. The amplified output in the collector circuit is supplied to the phase shifting circuit in order to overcome the losses.

Thus, the phase shifting circuit is getting energy continuously from the collector circuit to overcome the losses occurring in it and, therefore ensures undamped oscillations. The energy supplied to their tank circuit is of correct phase satisfying the bark Hausen criteria.

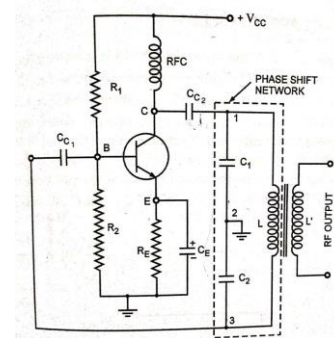

Fig 5 Colpitts oscillator

HARTLEY OSCILLATOR

The Hartley oscillator is just as popular as the Colpitts oscillator, and it's utilised as a local oscillator in a lot of radio receivers. The circuit is depicted in the diagram below. The Hartley oscillator circuit is identical to the Colpitts oscillator circuit, except that instead of two capacitors and one inductor, the phase shift network consists of two inductors L1 and L2 and capacitor C. The amplifier's output is connected to inductor L1, and the voltage across inductor L2 is used to produce the feedback voltage. When coil L1 and coil L2 are inductively connected, the result is an autotransformer. The junction of L1 and L2 cannot, however, be immediately grounded due to the direct connection. Another capacitor, CL, is utilised instead. The circuit works in a similar way.

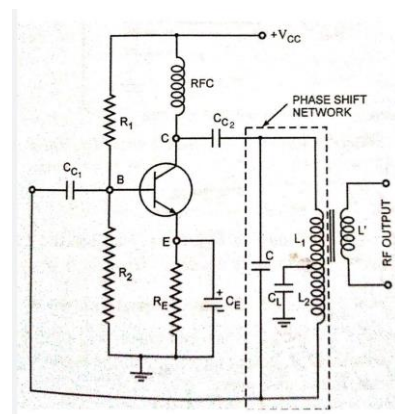

Fig 6 Hartley's oscillator

PHASE SHIFT OSCILLATOR

A Rc phase shift oscillator is extremely easy to use. Instead of a bipolar junction transistor amplifier, the circuit uses a common source field effect transistor amplifier, which is followed by a three-section RC phase shift network. The amplifier stage is self-biased using a capacitor bypassed source resistor R_s and a drain bias resistance R_d . This section's output is sent back into the gate. If the phase shift network's loading on the amplifier is believed to be insignificant, the amplifier produces a 180-degree shift between the amplified output voltage V_{out} and the input voltage V_{in} at gate. An additional phase shift is produced by the three-section rc phase shift network, which is a function of some frequency of operation, f frequency = 180 degrees. The total phase shift from the gate around the circuit and back to the gate will be exactly 0 at this frequency. If the magnitude of dictation appears to be large, this will be the frequency at which the circuit will oscillate.

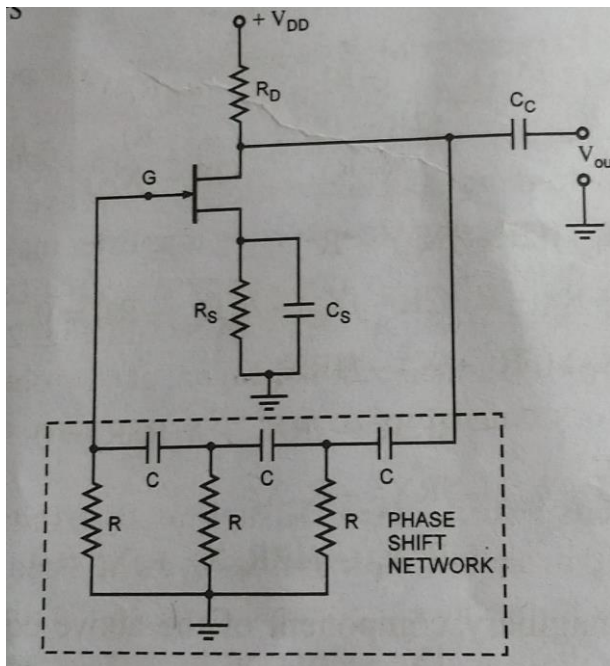

Fig 7 phase shift oscillator

PHASE SHIFT OSCILLATOR BENEFITS AND DISADVANTAGES ARE DESCRIBED BELOW.

ADVANTAGES

1. They start with low frequency ranges and work their way up to high frequency ranges (from a few HZ to several hundred kHz)
2. When compared to other oscillators, the Rc phase shift oscillator provides higher stability.
3. Because the output is sinusoidal, there is no distortion.

4. These oscillators are capable of working at both low and high frequencies.

5. Compared to other oscillators such as Wein bridge oscillators and Colpitts oscillators, the design of this Rc phase shift oscillator is particularly easy since it does not need negative feedback or stabilisation measures.

DISADVANTAGES

1. The output of this network is very small because it have small feedback network employed in it
2. When compared to Wein bridge oscillator the frequency stability is not that good.
3. In order to develop large feedback voltage it needs a high voltage battery approximately of 12 volts.

CONCLUSION

The working principles, operating frequencies, circuit diagrams of the sinusoidal oscillators are very important in understanding any complex circuits found in devices. The proposed review gives acknowledgement of different sinusoidal oscillators present and help them in performing better researches.

REFERENCES

1. Ramakanth A Gayakwad, Op-Amps and Linear ICs, 4th Edition, PHI, EE Edition, 2013.
2. R.F Coughlin and F.F Driscoll, Op-Amps and Linear Integrated Circuits, PHI, EE Edition, 4th Edition.2001.
3. JB Gupta, Electronic Devices and Circuits, S.K Kataria & sons, 5th Edition, 2012.
4. J.B.Gupta, "Utilization of Electric Power and Electric Traction" S.K.Kataria & Sons Publications, 2010.
5. Abhijit Chakrabarti, Sudipta Nath, Chandan Kumar Chanda, "Basic Electrical Engineering" Tata McGraw Hill, Publications, 2009
6. Hughes, "Electrical Technology", VII Edition, International Student -on, Addison Welsey Longman Inc., 1995.

BIOGRAPHIES



Pathan shamsherly khan
Passionate about exploring world and making it better than the past by means of advancements in technology.



B Purushotham
At most interests in gaining
knowledge and new technologies,
developing the nation



B. Vishwanath



A. Manaswini