

DESIGN AND DEVELOPMENT OF ELECTRO-MECHANICAL LIFTING JACK

Prashil Umesh Patil¹

*Mechanical Department
Vishwakarma Institute of
Technology
Pune, India.*

Bikash Das⁴

*Senior Engineer
Bharat Electronics Limited
Navi Mumbai.*

**Swatantri Dilip
Somkuwar²**

*Mechanical Department
Vishwakarma Institute of
Technology
Pune, India.*

Jagdish Pathade⁵

*DGM – Deputy General
Manager
Bharat Electronics Limited
Navi Mumbai*

Bhumika Sunil Pawar³

*Mechanical Department
Vishwakarma Institute of
Technology
Pune, India.*

Prof. Rajkumar Bhagat⁶

*Mechanical Department
Vishwakarma Institute of
Technology, Pune, India.*

Abstract— Power screws are wont to convert motility into translatory motion. A mechanical jack is an example of an influence screw within which a tiny low force applied during a horizontal plane is employed to boost or lower an oversized load. The advantage of a mechanical jack is that the ratio of the load applied to the hassle applied. the peak of the jack is adjusted by turning a lead screw and this adjustment is done either manually or by integrating an electrical motor. the planning and modification of quick lifting jackscrew with gear arrangements that are safe, reliable and capable of raising or lowering heavy load with little effort. This mechanism consists Lead screw, Bearing, Lead screw nut and assembly, Lead screw driving mechanism, Motor, structure, Lead screw selection. So, during this research paper we design and analyse the lead screw against eccentric load The designed motorised jack will save time and requires less human energy to control. Generally, jacks undergo buckling once they reach maximum load conditions (as per the tests conducted by consumer affairs). For this reason, we've got to develop the system which might use toggle jack which is automatic operating using motor. Vehicle's battery are often used as a source of power for this motor. the current study provides automated and simplified levelling system to help the levelling of the vehicle simultaneously reducing the manual involvement & effort.

Keywords—Screw Jack, Eccentric Load, Lead Screw, DC Motor, Horizontal levelling, Torque, Gear ratio.

1. INTRODUCTION

This system consists of lead screw, motor, gear box, bearings, nut. Shaft is connected to the lead screw through gear box arrangement. The gear box consists spur wheel arrangement. gear wheel can help to transfer the torque

from motor shaft to steer screw. the matter under our consideration is to style lead screw for eccentric load on that for any application like our project. The lead screw also called power screw utilized in machine to translate rotation in to linear motion. The lead screw is compact, simple in design and having large load carrying capacity. Lead screw has wide application in various mechanism. A Jackscrew may be a style of jack which functions by turning a lead screw. it's commonly wont to lift heavy load to a height. an honest example is that the car-jacks. within the case of a jackscrew, a little force applied within the horizontal plane is employed to lift or lower large load. The statement of problem has led to the motivation of designing a modified quick lifting jackscrew with gear arrangement. In day-to-day life it's very tedious job to control the jack manually and it's also a really time-consuming work further. the overall idea of project is to attenuate the human effort while operating the jack. A mechanical jack could be a portable device consisting of a screw mechanism want to raise or lower the load. the most parts of mechanical jackscrew (cylindrical) jack are Body, Screw, Nut and Thrust Bearings. The principle on which the jackscrew works is analogous to it of an machine. The jack is created out of varied varieties of metal, but the screw itself is usually made out of lead. While screw jacks are designed purposely for raising and lowering loads, they're not ideal for side loads, although some can withstand side loads looking on the diameter and size of the lifting screw. Shock loads should even be avoided or minimized. Some screw jacks are built with anti-backlash. The anti-backlash device moderates the axial backlash within the lifting screw and nut assembly to a regulated minimum. great deal of warmth is generated within the jackscrew thanks to friction between various parts and long lifts can cause serious overheating. To retain the efficiency of the jackscrew, it must be used under ambient

temperatures, otherwise lubricants must be applied. The screw contains a thread designed to resist an unlimited amount of pressure. this can be thanks to the very fact that it's generally holding up heavy objects for an extended amount of your time. Once up, they normally self-lock so they will not fall if the operator lets go, and that they waiting well to the wear and tear of repeated use. it's made from a bolt and nut assembly and its working rule is analogous to it of an simple machine. Where a thread wound round a shaft rotates in its bearings while the nut has revolution against the resisting axial force. This project is geared towards researching and developing a jack that's power operated, time saving and more efficient. Thus, achieving one amongst the goals of technology by making life easier for the tip user, proper design considerations got to the look of this project including the stresses, bending moment of the shafts, strength of materials and also the maximum load it's expected to hold, thus making safety and reliability.

2. COMPONENTS OF POWERED JACK

Lead screw: A lead screw, also known as a power screw or translation screw, is a screw that is used as a linkage in a machine to translate rotary motion into linear motion.

Bearing: A bearing is a machine element that constrains relative motion to only the desired motion, and reduces friction between moving parts

Lead screw nut and assembly: Lead screws are threaded bars of metal and a threaded nut which is in direct contact with the screw; this generates sliding friction as opposed to rolling friction from other alternative devices

Lead screw driving mechanism (Motor): a machine that supplies motive power for a vehicle or other device with moving parts.

3. DESIGN PROCEDURE

The system is lifted and leveled using 4 jack, two fitted at the front and two fitted at the rear of the system. Capacity of jack is decided in such a way that two jack at a time can take load of the overall system. The overall Cg and Jack location are shown in a schematic diagram below. Here, two cases are considered one is diagonal and other is alternate.

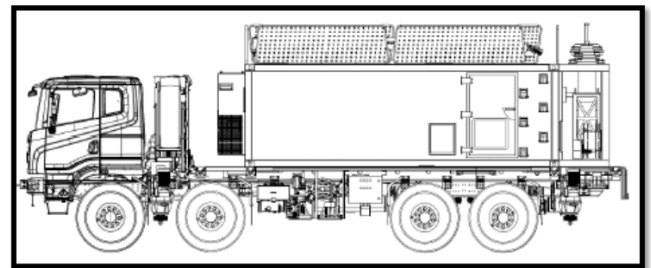
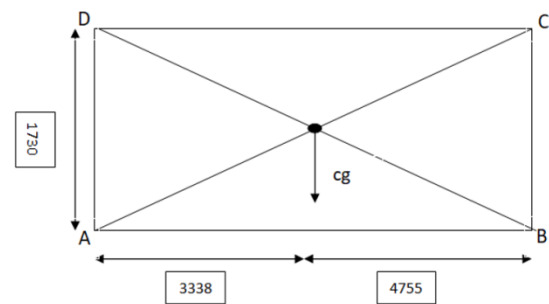

Fig1^[1]. Fully-loaded TATA Defence Combat 8X8

3.1.CALCULATING LOAD ACCORDING TO CG



Accordingly,

CASE1: When jack diagonally touching the ground

Moment about A: $m@A = 35 \cdot 3448.25 - F3(8281.28)$

$F3 = 14.57T$

Moment about C: $m@C = 35 \cdot 4833.03 - F1(8281.28)$

$F1 = 20.4T$

CASE2: ALTERNATE

Moment about A: $m@A = F2(8093) - 35(3338)$

$F2 = 14.43T$

Moment about B: $m@B = F1(8093) - 35(4755)$

$F1 = 20.56T$

Maximum load is 20.56T so 22T load is taken.

3.2DESIGN OF LEAD SCREW MECHANISM

Lead Screw design in lead screw selection process, we find out length of lead screw, material selection for screw and nut, outer or major diameter, minor diameter, pitch diameter, pitch, lead, type of thread.

- **Material selection.**
- Material for screw is steel. Material for nut is cast iron. We have considered following material properties:

TABLE I

Sr no.	Parameters	Values
1.	Yield strength of material	330MPa
2.	Shear strength of material	170MPa
3.	Young's Modulus	200GPa
4.	Coefficient of friction	0.1
5.	Factor of safety	3
6.	Nut factor weigh height	2

3.2.1 Stress calculations:

Permissible Compressive stress = $330/3 = 110\text{N/mm}^2$

Direct compressive stress $\sigma_c = Wc/Ac$

$dc^2 = (4*22*10000)/3.14*110$. $dc = 50.47\text{mm}$

Major diameter $dm = d - p/2 = 65$

3.2.2 Lead Calculation

$l = n * p * (5) = 10\text{ mm}$

3.2.3 Calculation of Coefficient of friction

The coefficient of friction steel screw & Cast iron nut is normally taken as 0.1 the maximum possible value of coefficient of friction is 0.18 this occurs when, friction occurs maximum on account of poor lubrication we will consider the worst condition where the operator is careless about the lubrication of the screw.

3.2.4 Torque Calculation

- a. Load: $Pr = F \tan(\theta + \lambda) = 34804$
- b. Torque for raising load: $Tr = Pr * dm / 2 = 1131.3$

3.2.5 Stress Calculation for checking design is safe

- a. Torsional stress: $\zeta = 16 * Tr / 3.14 * dc^3 = 26.68\text{MPa}$
- b. Principle stress: $\sigma_x = [W / (\pi / 4 * dc^2)] / 2 = 77.84$
- c. Maximum principal stress: $\sigma_1 = \sigma_x / 2 \pm = 86.1067$

3.3 DESIGN OF NUT

TABLE II

Sr no.	Parameter	Value
1.	Yield stress of selected Nut material	152MPa
2.	Shear Stress of selected Nut material	100MPa
3.	Value of unit Pressure from table (Pu)	11MPa
4.	Coefficient of friction	0.1
5.	Factor of safety	3
6.	Nut factor weigh height	2
7.	Type of Screw	Jack screw
8.	Material of screw	Steel
9.	Material of Nut	Cast Iron
10.	Bearing stress	12-17MPa
11.	Low speed	<2.5

3.3.1 Determining height of nut

- a. $t = \text{thickness of screw} = p/2 = 10/2 = 5\text{mm}$
- b. $H = \text{height factor} * \text{pitch dia} = 130\text{mm}$
- c. $N = \text{no. of threads engaged} = 13$
- d. $\text{Bearing stress} = \text{load/Area} = (4*22*10000)/3.14(70^2 - 60^2) = 16.58\text{MPa}$

3.3.2 Calculating stress values

3.3.2.1 Transverse shear stress in Nut

- a. $R_s(\text{Nut}) = W/\pi n d c t = 11.6\text{MPa}$
- b. $\text{F.O.S} = \text{Allowable shear stress}/\text{stress} = 8.62$

3.3.2.2 Compression stress in Nut

- a. $\sigma_c(\text{Nut}) = W/\pi n (d_{\text{major}}^2 - d_c^2) = 2.69\text{MPa}$
- b. $\text{F.O.S} = \text{Allowable compressive stress} / \text{stress} = 56.5$
- c. $\text{Outer diameter of Nut } D = 87.76\text{mm}$

3.3.3 Checking for self-locking Condition

$\pi \mu d m > 10 \Rightarrow 0.1 * 3.14 * 65 > 10 \Rightarrow 20.41 > 10$

3.3.4 Checking for Buckling

- a. $I = \pi/64 * (d_c)^4 = 0.635850 * 10^{-6}$
- b. $r = \sqrt{I/\sqrt{A}} = 15\text{mm}$
- c. $\text{Stroke Length} = 477$
- d. $\text{Slenderness ratio} = \lambda = l/r = 76.93$

As intermediate column is from 40-120mm we have taken the Intermediate Column.

3.3.4.1 Condition:

one end free and other fixed

$l_{\text{eff}} = 2l = 2 * 577 = 1154\text{mm}$

$$\frac{1}{Pr} = \frac{1}{Pc} + \frac{1}{Pe}$$

- a. $Pe = \pi^2 EI / (l_{\text{eff}}^2) = 1035.6786 * 10^3 \text{ N}$
- b. $Pc = fcA = 817321.40\text{N}$

c. $Pr = 10^6(0.4568172) = 4568172$

For Intermediate Column; Empirical Formulae

W_{cr} by Euler's Formula is P_{cr}

d. $\text{Checking F.O.S} = P_{cr}/220000 = 4.707$

3.4 GEAR BOX DESIGN

TABLE III

Sr no.	Parameter	Value
1.	Deployment time	180secs
2.	Stroke Length	477
3.	Diameter of screw	60mm
4.	Lead of screw	10mm
5.	Frequency	50Hz
6.	Motor Speed	960RPM
7.	Gear ratio	1:60
8.	Torque	1131.130Nm
9.	Screw Efficiency	0.85
10.	Gear box	0.85

- a) $\text{Linear speed of Nut} = 477/180 = 2.65\text{mm/s}$
- b) $\text{Rotation required to raise load by } 477\text{mm} = 477/10 = 48$
- c) $\text{Rotation Speed} = 48/3 = 16\text{RPM}$
- d) $\text{Gear ratio} = 16/960 = 1:60$
- e) $\text{Th. Power} = 2 * 3.14 * NT/60 = 2 * 3.14 * 16 * 1131/60 = 1895$

f) Actual Power = $1895/0.85 \times 0.85 = 2622W$
(Approx. **3kW**)

$$N_2/N_1 = 1/60 = 1/2 \times 1/2 \times 1/3 \times 1/5$$

Taking spur gear of module **1.5**

3.5 GEAR ARRANGEMENT

TABLE IV

Sr no.	Gear	Teeth	Diameter
1.	1st gear	20	30
2.	2st gear	40	60
3.	3st gear	60	90
4.	4st gear	100	150

3.6 SPEED OF SHAFTS

TABLE V

Sr no.	Shafts	Speed(RPM)
1.	Shaft 1	960
2.	Shaft 2	480
3.	Shaft 3	240
4.	Shaft 4	80
5.	Shaft 5	16

3.14 DETERMINING DIAMETER OF SHAFTS

TABLE VI

Sr no.	Torque(N m)	Diameter(mm)	Approx. Diameter
1.	358.2	26	30
2.	119	18	20
3.	119.4	18	20
4.	59	14	20
5.	29.5	11	15

3.15 BEARING SELECTION

- We selected taper roller bearing because, The line of action of the resultant reaction makes an angle with the axis of bearing.
- This reaction can resolve into radial and axial component "Tapper roller bearing is suitable for combined axial and radial loading."
- The conical surface of each roller is suitable to pressure, which acts to the normal to the surface therefore "If the external force acting on the bearing is purely radial it induced a thrust reaction within a bearing to avoid the separation of cup from cone. This thrust traction must be balanced by equal and opposite force.
- This is balanced by at least two taper roller bearings on the same shaft, so we are using same bearing for both ends.

Sr no.	Shaft	Outer diameter (mm)	Width(mm)
1.	Shaft 1	62	17
2.	Shaft 2	37	9

3.	Shaft 3	37	9
4.	Shaft 4	37	9
5.	Shaft 5	62	9

TABLE VII

4. SOLIDWORKS DESIGN

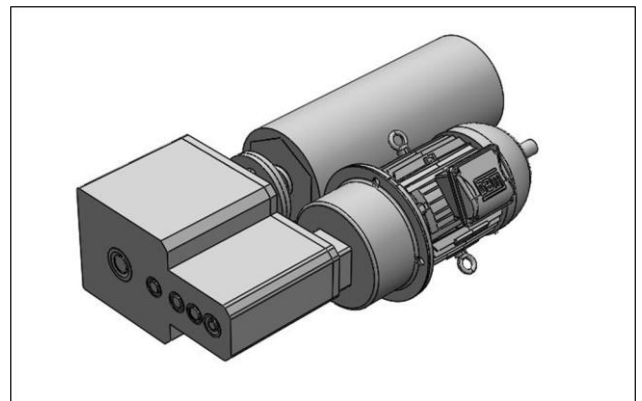

Fig4. Isometric view

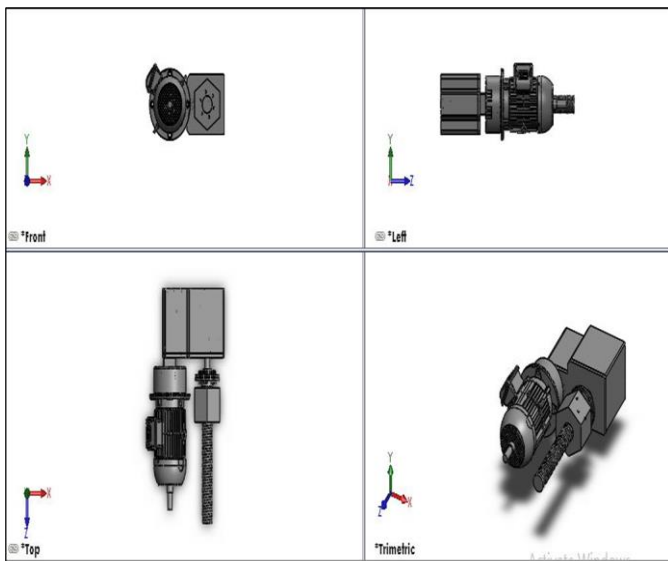

Fig2.Four-view of Design

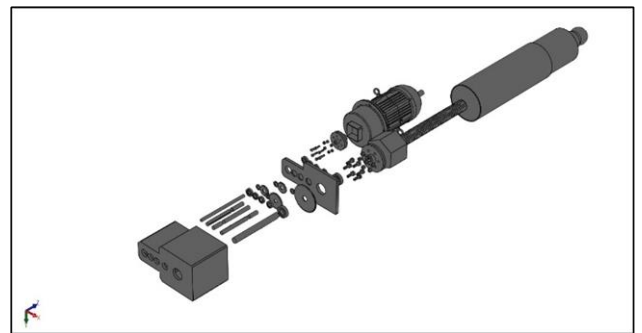

Fig5. Exploded view of Design Assembly

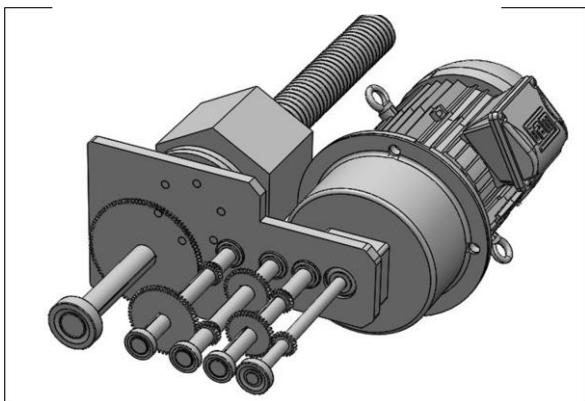

Fig3. Gears Representation

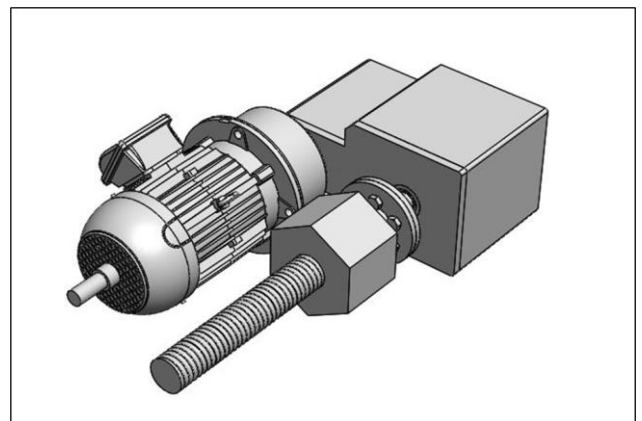

Fig6. Design Assembly

5. RESULTS

TABLE VIII: TECHNICAL SPECIFICATIONS

Sr no.	Parameters	Value
1.	Jack type	Electro-mechanical
2.	Capacity	22T
3.	Stroke length	477mm
4.	Lead screw diameter	60mm
5.	Lead screw pitch	10mm
6.	Nut size	130mm
7.	Gear ratio	60:1
8.	Deployment time	180secs
9.	Power input	3KW
10.	Input speed	960RPM
11.	Input torque	597Nmm

6. CONCLUSION

Design of complete jack and its components under different loading conditions is studied and its principal dimensions are found out. Same specifications can be used for manufacturing and be given to jack manufacturers for production. Also, the design of nut, gear design along with determining diameter and speed of shafts and bearing selection is done.

7. FUTURE SCOPE

Few improvements could be done in the future to increase safety and reliability

1. The gears can be improved by replacing spur gear into bevel gears.
2. The gear arrangement can be more compact so that there should be no extra load on the vehicle or the platform.

8. ACKNOWLEDGEMENT

We express our deepest gratitude and heartfelt thanks to our guide, Professor Rajkumar Bhagat (Mechanical Department), for his expert guidance, constant encouragement, constructive criticism, and inspiring advice throughout the completion of this report. We are thankful to the Mechanical Engineering Department, VIT Pune who provided us this opportunity to explore the topic through this evaluation component. We are grateful to Prof. Dr. M.B. Chaudhari sir HOD, Department of Mechanical Engineering for such a helpful component in academics for being our guardian same, guiding us over weeks to improve upon our progress. Last but not least we would like to thank Prof. Dr. R M Jalnekar sir for giving us these opportunities.

9. REFERENCES

- [1] Karl t Ulrich, Anita Goyal, Product design and development 4th edition, TATA McGraw Hill publication, pp32-142 2009
- [2] Shigley's Mechanical Engineering Design, 8th edition, TATA McGraw Hill publication, pp597-652, 2009
- [3] Varun Gopinath, Design, Simulation and Demonstration of a Parallel Parking Mechanism for a City Car, 1998
- [4] A.A. Thomas, Lifting and Sideward Driving Mechanism for Automobiles, 2090768, 1937
- [5] Pin Yeh, Structure of Lateral Driving device for car, US4998595A, 1989
- [6] [1] V.B. Bhandari, Design of machine elements, 3rd Edition, Tata McGraw Hill, 2010