

# Gas Leakage Detection Using IoT

Shreya P<sup>1</sup>, Raghavendra R<sup>2</sup>

<sup>1</sup>PG student, Department of Computer Application, JAIN University, Karnataka, India

<sup>2</sup>Assistant professor, Department of Computer Application, JAIN University, Karnataka, India

\*\*\*

**Abstract** - In today's world, safety is critical, and good safety systems must be put in place. The primary goal of this paper is to come up with a microcontroller-based toxic gas detection and alerting system. Liquefied petroleum gas is a significant and power source that is mainly used for cooking in houses. Since LPG is stored in a bottle, it is easily damaged. In any case, when the gas cylinder, controller, and tube are not in great state, breaks occur, resulting in a issue. Accidents can cause problems such as suffocation and can start of fire. Installing gas leakage detectors in vulnerable areas is the most important measure to avoid accidents caused by gas spill. The main goal of this paper is to present a structure for identifying and removing gas spillage in defenseless premises. One such device is the gas spill sensor, which detects and alerts people to gas spills in their early stages. Gas sensors with high sensitivity to propane and butane. The gas leak detection system includes a GSM module that sends SMS messages when a gas leak is noticed.

**Key Words:** Node MCU, ESP8266 WIFI module, LCD, Servo Motor, Buzzer, GSM module, MQ6 Sensor, LPG.

## 1. INTRODUCTION

As a result of LPG gas detection, many incidents, such as explosions and fires, have occurred. Such incidents can have serious consequences. This leakage detection system will detect external leaks and send data to a module. IoT systems do not need human intervention. A system with large electric and mechanical power is used to detect gas. This detection system will notify us of the leakage and also turn off the gas cylinder's lever, preventing any further leakage. Furthermore, this system sends an email and a text message to the affected individual. This improves the safety of any gas setup in any situation.

Any flammable substance on the site that comes in touch with gas can result in property loss, harm lives and other consequences. Automobiles such as cars and buses, as well as the areas where they are manufactured, are among the primary sectors under constant threat.

## 2. OBJECTIVE

LPG leaks are now a concern both in home and in the workplace. It is unavoidably dangerous if the problem is not identified and corrected as soon as possible. The main goal of the project is to use IoT to detect gas leaks from LPG cylinders, which are common in Indian homes, and to alert the user and the surrounding area. A servo motor will also turn off the supply gas, as will the knob, reducing

the risk of an accident. A gas sensor is used as input. A buzzer is attached to the circuit to indicate that the user is offline.

## 3. RELATED WORK

[1] Azibek [12] investigated a smart home care system that monitors the safety of old people. If abnormal health rate vitals are discovered, it sends an email to medical personnel. This home care system also includes sensors for identifying fires and a camera for detecting burglars. The system sends notifications to people struggling from short term memory loss concerning daily routine duties.

[2] Yoshida (2009) examines a fuel power supply system that consists of a fuel battery into which a reactive gas is supplied to generate power, a pipe connecting to the fuel battery, and a technique for sensing a gas leakage in the fuel power source. The primary goal was to improve performance.

[3] Fraiwan [11] describes a wireless system that can detect gas leaks in homes. The system is comprised of two primary components: the first checks to see if the vapor pressure exceeds a predefined limit, and the second checks to see if the concentration is below a predefined limit. When this happens, an alarm is triggered, and a signal is sent to a mobile device.

[4] Ilshak [13] described a wireless gas leak detection module that can be installed in the home to detect LPG leaks. The module checks the sensor to see if the value of the gas has risen above a certain threshold. When this happens, the alert is triggered, and a SMS is sent to a specified user.

[5] "PORTABLE GAS DETECTION DEVICE WITH WARNING SYSTEM" by Tarun Joseph

The authors of this paper have explained a gas detection method that will regularly monitor the toxic gases around them, the results of which can be viewed via our Android app, and an alert are sent if the limit is seen nearing.

The below fig1 illustrates the system architecture:

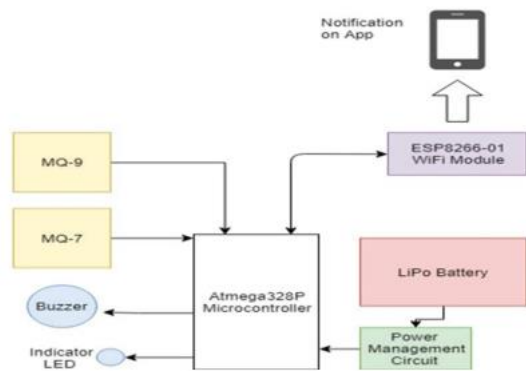

Fig -1: System Architecture

#### METHODOLOGY:

1) Sensor Data Acquisition: The MQ7 and 9 sensors are linked to the Atmega328P microcontroller. These sensors can detect LPG, CO in the air. Based on the value of gases in the environment, the sensors produce varying voltage values.

2) Data is serially transmitted from the microcontroller to the ESP8266 chip for publication. The received data is first changed into sensor values for MQ7 and 9. The information is routed to the appropriate application topic.

3) App Notification: Displays the sensor values and the current state of each sensor. It shows information such as temperature.

#### LIMITATIONS:

Because this model only uses the app, the message will not be delivered if the user is out of network range or has difficulty connecting to the internet.

The node MCU then sends a signal to any devices that are not connected internally. When a Philips microcontroller is used instead of an AT89C51, the microcontroller's efficiency and memory can be increased. SMS can be sent to users.

#### 4. CONCLUSION

The goal of this project is to create a monitoring and detection system that will meet safety standards and prevent free accidents caused by leakage. The system detects gas in the atmosphere and continuously updates and displays the gas value, which the user can easily see through the mobile app. This system responds faster and can disseminate critical information more quickly than manual methods. In the event of a leak, the system notifies and quickly responds by sending SMS to the appropriate authority.

#### REFERENCES

- [1] Xiao Liu, Sitian Cheng, Hong Liu, ShaHu, Daqiang Zhang and Huansheng Ning.(2012). A survey on Gas Sensin Technology, *Sensors* 2012, 12, 9635-9665; doi: 10.3390/s120709635.
- [2] Keat Ghee Ong, Kefeng Zeng and Craig A. Grimes. (2002). A Wireless, Passive Carbon Nanotube-Based Gas Sensor. *IEEE Sensors Journal* 2(2): 82-88; doi:10.1109/JSEN.2002.1000247.
- [3] Soan M. Kanan, Qussama M. El-Kadri, Imad A. AbuYousef and Marsha C. Kanan. (2009). Semiconducting Metal Oxide Based Sensors for Selective Gas Pollutant Detection. *Sensors* 2009, 9(10), 8158–8196;
- [4] Edward Naranjo, Shankar Baliga and Philippe Bernascolle. (2010). IR Gas Imaging in an Industrial Setting. *Thermosense XXXII*, edited by Ralph B. Dinwiddie and Morteza Safai, Proc. of SPIE Vol. 7661, 76610K; doi:10.1117/12.850137.
- [5] Michael Barr. "Embedded Systems Glossary". Neutrino Technical Library. Retrieved 2007-04-21. 2. Heath, Steve(2003). *Embedded systems design. EDNseries for design engineers* (2 Ed.). Newness.p.
- [6] W. Yi, W. Ke-Jia, W. Qi and T. Feng, "Measurement of CH4 by differential infraredoptical absorption spectroscopy," 2009 9<sup>th</sup> International Conference on Electronic Measurement & Instruments, Beijing, 2009, pp. 1-761-1- 766.
- [7] Nedyalko T. Katrandzhiev and Nikolay N. Karnobatev, "Elaboration of a Microprocessor Unit for Gas Measurement with Sensor Mq-6", *Scientic Works of University of Food Technologies* 2016 Volume 63, Issue 2.
- [8] D. S. Simbeye, "Gas Leakage Detection System (GLDS)," *Tanzania Journal of Engineering and Technology*, vol. 34, 2017.
- [9] Shital Imade, Priyanka Rajmanes , Aishwarya Gavali , Prof. V. N. Nayakwadi "GAS LEAKAGE DETECTION AND SMART ALERTING SYSTEM USING IOT" *International Journal of Innovative Research & Studies* Volume 8, Issue II, FEB/2018 ISSN NO : 2319-9725.
- [10] Tarun Joseph, Kirti Tyagi, Dr. Y.S.Rao "Portable gas Detection Device With Warning System "in 2019 *Global Conference for advancement in Technology(GCAT)* Volume 6, Issue 3, May-June-2020, ISSN (Online): 2395-566X
- [11] L. Fraiwan, K. Lweesy, A. Bani-Salma, and N. Mani, "A wireless home safety gas leakage detection system," in

2011 1<sup>st</sup> Middle East Conference on Biomedical Engineering, pp. 11-14, 2011.

- [12] B. Azibek, S. Zhigerova, and M. S.Obaidat, "Smart and Efficient Health Home System," in Emerging Research in Data Engineering Systems and Computer Communications, ed: Springer, pp. 677-691,2020.
- [13] S. N. Mahmood, A. J. Ishak, and S. T. Hussain, "GSM based gas leak monitoring system," Periodicals of Engineering and Natural Sciences, vol. 7, pp. 670-678, 2019.