

Innovative Sanitization Chamber for Covid19

Dr. Manisha Mhetre¹, Mohini Lad²

¹Assistant Professor, Dept. of Instrumentation & Control Engineering, Vishwakarma Institute of Technology, Pune, India

²Student, Dept. Instrumentation and Control Engineering, Vishwakarma Institute of Technology, Pune, India

Abstract - This paper depicts a multipurpose autonomous sanitization chamber to clean different items or objects we bring from outside or those which interact with the COVID-19 infection like cell phones, PCs, vegetables, organic products, staple things, and so forth. To make the chamber powerful and profoundly proficient, it has been given three sterilization modes whose time goes from 5 minutes to 15 minutes. Because of the numerous modes, the chance of killing the infection is very high. The first sanitizing mode is for 5 minutes in which the UV-C light will get ON. In the second sanitizing mode that is for 10 minutes in which UV-C lights will turn ON for 8 minutes and the Mist will turn ON for 2 minutes. Also, for the last cleaning mode that is for 15 minutes in which the heater will turn ON for 5 minutes, UV-C light for 8 minutes and Mist for 2 minutes. When the individual keeps any item or object in the chamber, that item is presented to a specific cleaning measure contingent on the mode chosen by the individual. The chamber works autonomously by identifying the presence of an item or object with the help of an ultrasonic sensor, and by recognizing the situation of the chamber entryway. The chamber is referred to as the 'Multipurpose Sanitization Chamber'.

Key Words: Disinfecting, mist, modes, sterilization, uv-c lights

1. INTRODUCTION

The occurrence of the Corona virus has afflicted innumerable individuals around the planet. Regulating this actual deadly disease is now a main concern of the scientific community. Human beings can get affected by this disease in some or the opposite way, mainly from one-to-one contact by the propagation of infected particles originated from the verbal and nasal entries, or by touching a contaminated surface. In this present situation, there's no full-proof vaccine present in the market, which can cure the COVID-19 virus completely.

During this outbreak, poor sanitation and hygiene practises may lead to an increase in infection rates. This corona virus can survive in aerosols for up to 3 hours, 4 hours on copper surfaces, 3 days on steel and plastic surfaces, and 24 hours on cardboard surfaces. Without proper sanitization, the pathogen can spread swiftly through touch surfaces and the air. Effective surface and air disinfection can be ensured by early regulation and counteraction of further virus propagation. COVID-19 viral

infections are effective with 0.1 percent hypochlorite solution in 1 minute, according to the literature. When the temperature and humidity are high, the corona virus transmission is reduced and diminished. [2]

So, there's a requirement of a strong disinfection system to interrupt the chain of the virus from diffusing, regardless of the sanitation of people. An electronic sanitization chamber can operate contactless sanitation of all items or objects. The sanitization chamber should be autonomous, irrespective of any kind of objects need to be sanitized and without individuals' interference for catching the ailment on the base of items or objects. Different sanitization methods are available like hydrogen peroxide mist can be used to disinfect the item or object. Subsequently UV light can also be utilized for disinfection purposes; however, selection of the wavelength of UV radiation is exceptionally crucial. If a calculative choice is not taken then it might be unsafe and serious to the health, skin, and eyes of the human beings. These techniques are utilized separately in different instruments for sanitization.

2. Literature Survey

"The system proposes a powerful autonomous disinfection tunnel that may be used to disinfect COVID-19 virus outside surfaces such as clothes and open body parts in public places such as airports, office space, educational institutes, and shopping malls. Two chambers with three different disinfection methods are provided to make the tunnel effective and efficient. As a result, the chances of destroying the Corona virus are quite good. The solution is sprayed on the person entering the chamber by chamber 1. As a disinfection, use a dilute solution of an approved chemical or any Ayurvedic/herbal disinfectant. Once the individual enters chamber 2, they come in contact with the hot air at 70 °C alongside far UVC rays (207–222 nanometres). The feature of this chamber is it detects a person using ultrasonic sensors which makes it automatic. This disinfecting tunnel is called as the 'Techno Advanced Disinfection Tunnel' (TADT)" [3].

Another paper tries to design the Viroreaper, a COVID chamber. This works on the basis of high-temperature heating and humidity exposure, which, according to current research conducted throughout the world, is successful in regulating and neutralising the virus. The temperature in this chamber is kept between 700 and 800 degrees Celsius,

with humidity levels between 80 and 85 percent, for the length required to neutralise the corona virus. This gadget is designed to sanitise a variety of materials, including polyvinyl chloride (PVC), wool, polyester, acrylic, polypropylene, cotton, newspaper, steel, and leather. [4]

3. Materials and Methods

The proposed technique attempts to create a cost-effective sanitization system for ordinary people like us by combining sanitization and disinfection. While it may appear that there have been a few chances in the field of sanitization and disinfection systems in the past, it has been acknowledged that these systems are frequently expensive due to their excessive complexity. cost, not only this but the available opportunities provide less features. As demand for sanitization and disinfection is quite high during this Covid19 pandemic it becomes crucial to have many options available at a time while sanitizing items. An attempt has been carried out to devise a system that's cheap and as a onetime investment, keeps each one safe from this virus. The research project developed 'Multipurpose Sanitization Chamber' offers three different sanitizing modes and method. As this chamber offers three different methods that are heat, UV-C light and mist to sanitize or disinfect items/objects. Due to these three different method facilities the user gets a feasible to sanitize and disinfect large variety of items/objects from groceries to medical equipment's. Also, this chamber provides three different timing modes, so that the user can select the timing depending upon the item/object he/she wants to sanitize or disinfect. This chamber offers various advantages then the other systems present in the market. This chamber will encourage sanitizing large variety of items/objects at low cost.

2.1 System block diagram

The Fig. 1 shows the system block diagram.

The chamber consists of three different sanitization modes i.e., heat, UV-C lights and mist. Also, this chamber involves different sanitization timings to sanitize and disinfect different items/objects.

The hardware of chamber consists of Arduino Uno as the microcontroller, pushbuttons, 5V 8-channel Relay module, UV-C lights, Mist sprayer, dryer, 1684 LCD display, ultrasonic sensor, and door switch. The UV-C light and the dryer are powered using 230V power supply whereas rest of the components are powered using 5V from Arduino Uno.

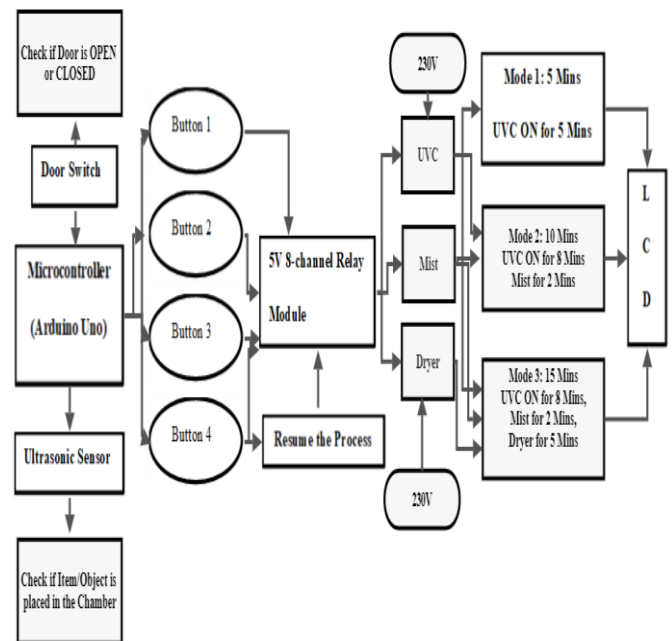

Fig. 1 System Block Diagram

2.2 Hardware Description

Before going for actual fabrication of the system, CAD model is developed using SolidWorks and shown in Fig. 2, Fig. 3 and Fig. 4.

Fig. 2 shows CAD model of Multipurpose Sanitization Chamber. To get a basic idea about our hardware, we started with CAD model for Multipurpose sanitization Chamber. We also designed a panel box on which display, and buttons are placed. Not only that a stand is also designed on which the chamber was placed.

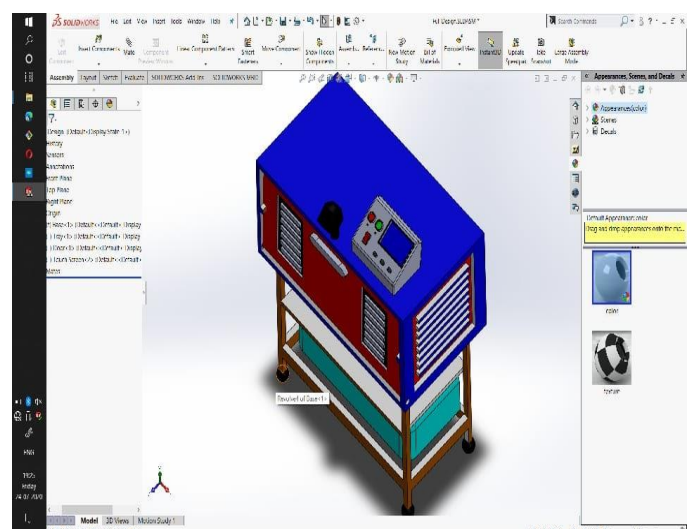

Fig. 2 CAD Model of Multipurpose Sanitization Chamber

Fig. 3 shows Section arrangement in Multipurpose Sanitization Chamber. To give the user the feasibility to sanitize more objects at one time, we added a section in the chamber. Also, to make it more reliable we made this section removable, so that if the user wants to sanitize big item/object he/she can remove this section and sanitize it easily. The base of the stand has four wheels to facilitate movement.

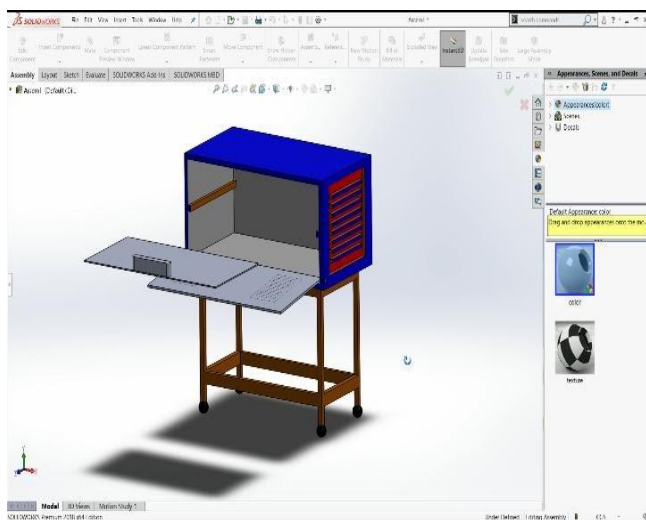

Fig. 3 Section arrangement in Multipurpose Sanitization Chamber

Fig. 4 shows Inner placement view of Multipurpose Sanitization Chamber. In this CAD model of chamber, we have used three UV-C lights, first UV-C light is placed at the back side of the chamber, second and third UV-C light at the right side of the chamber. The mist sprayers are placed at the right and left side of the chamber, whereas the dryer at the back side of the chamber as shown below.

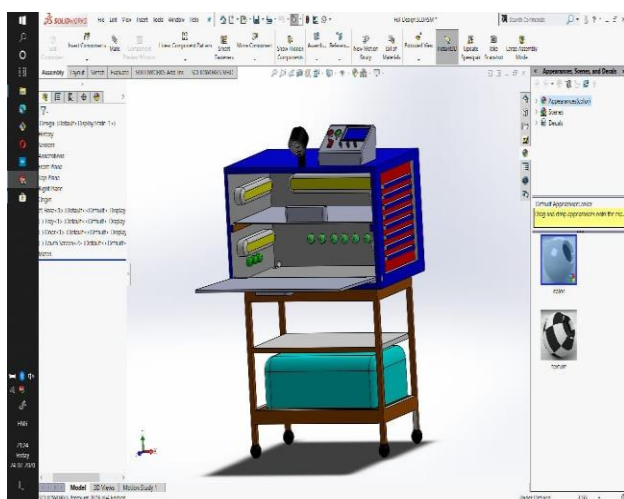

Fig. 4 Inner placement view of Multipurpose Sanitization Chamber

The device was built in three stages: structural construction, electronic assembly, and microcontroller programming. This chamber consists of 3 UV-C germicidal light (Phillips, model TUV T8), connected on left, right and back side of chamber. The UV-C is powered using 230V. This UV-C light was connected to the 5V 8-channel relay module, which makes the UV-C ON depending on the input received from the microcontroller i.e., Arduino Uno. The 5V 8-channel relay module are powered using Arduino Uno. The chamber consists of 2 dryers connected on upper back side of the chamber which can be used for deep sanitization of medical equipment's. The dryer's is also powered using 230V and is further connected to the 5V 8-channel relay module, which will make it ON depending on the input received from the Arduino Uno. The chamber also consists of 2 mist sprayers connected on the lower left side of the chamber. The mists are powered using Arduino Uno and is further connected to relay module, which will make it ON depending on the input received from Arduino Uno. The chamber also consists of 4 pushbuttons, one to make the Mode 1 ON, second to make the Mode 2 ON, third to make the Mode 3 ON, and the last one to resume the process. These pushbuttons are powered using the Arduino Uno, depending on the input received from pushbuttons, Arduino Uno will send the signal to relay to make the respective relay ON. As, UV-C lights are harmful for human beings this chamber comprises of ultrasonic sensor and door switch. This sensor and switch are powered using Arduino Uno. The ultrasonic sensor is placed on the upper side of the chamber which will check if the item/object is placed in the chamber or not, and further will send this signal to the Arduino Uno. The door switch is located on the door of the chamber which will check the whether the door is open or not and will send the status of the door to the Arduino Uno. In this approach, the user is alerted to the condition of the door and whether or not the item/object has been placed in the chamber. All the information related to the process or status of the door or item/object is displayed on the 16*4 LCD display which is powered using Arduino Uno. Fig. 5 shows an electrical diagram of the connections.

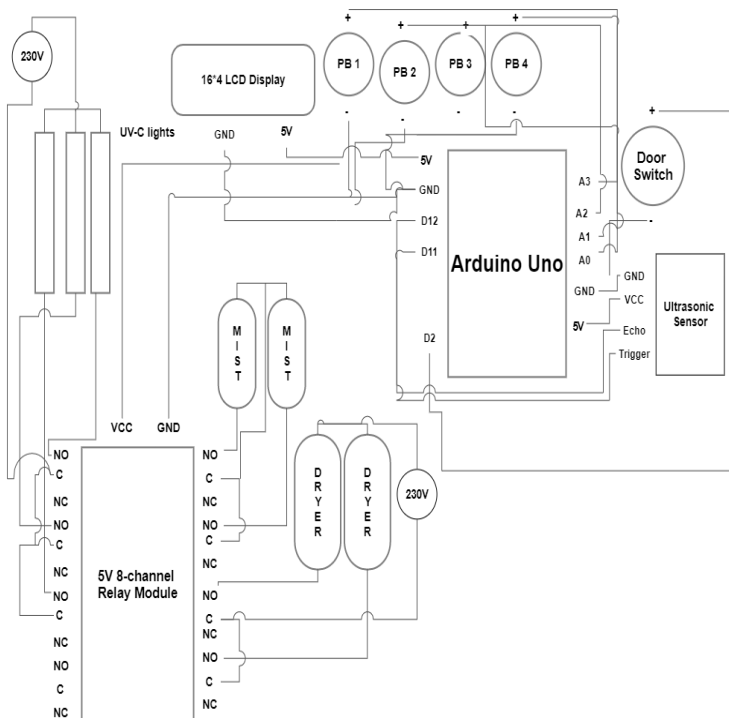

Fig. 5 Electrical Diagram of system

Fig. 6 shows the stand of the Multipurpose Sanitization Chamber which will provide height to the Chamber. The dimension of the stand is 1.8 x 1.4 x 1 foot. The pipe used to make this stand are made of stainless steel. The pipe used were circular in shape with diameter of 40mm. The pipes were connected to each other using 12 PVC equal tee and 4 PVC 90° elbow.



Fig. 6 Stand of the Multipurpose Sanitization Chamber

Fig. 7 shows actual inner arrangement of Multipurpose Sanitization Chamber.

The dimensions of the outer box of the chamber are 49.5 x 43 x 37 cm (width x depth x height). The dimensions of the inner box are 42 x 40 x 35 cm (width x depth x height). The outer layer of the outer box of chamber is made up of bagasse hydraulic press sheet and inner layer of outer box is made up of non-conductive steel. The outer layer of the inner box is made up of wood and inner layer of the inner box is covered with mirror from all the sides. It consists of different electronic components like Ultraviolet light, dryers, mist sprayers, ultrasonic sensor, door sensor, relays to actuate the process, LCD screen, pushbuttons. Also, the chamber is covered with mirror from all the sides to increase the effect and of UVC light while disinfecting the item/object.

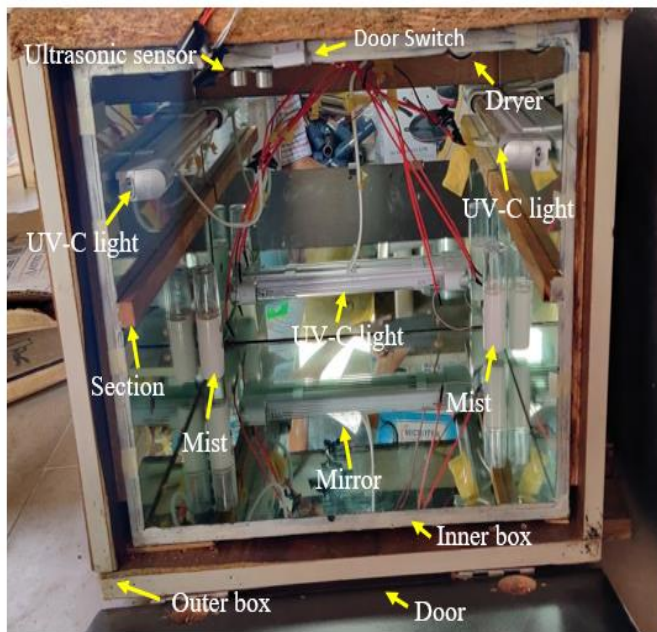

Fig. 7 Actual inner arrangement of Chamber

Table 1 Technical Specifications of the components

S No.	Component	Technical specifications	Nos.
1	UV-C light	Power: 8W, wavelength: 222/253nm	3
2	Dryer	Power: 1000W, Voltage: AC220V, Size: 10.9x7.5x17 cm	2
3	Mist sprayer	Size: 5 x 5 x 5 cm	2
4	Power source	AC	-

Table 1 gives of the list of components used in the building up of the system.

2.3 System Flowchart

After assembling of electrical components and hardware, programming of the system has been done for proper functioning of the total system. Arduino programming has been done according to the flow chart explained in the Fig. 8.

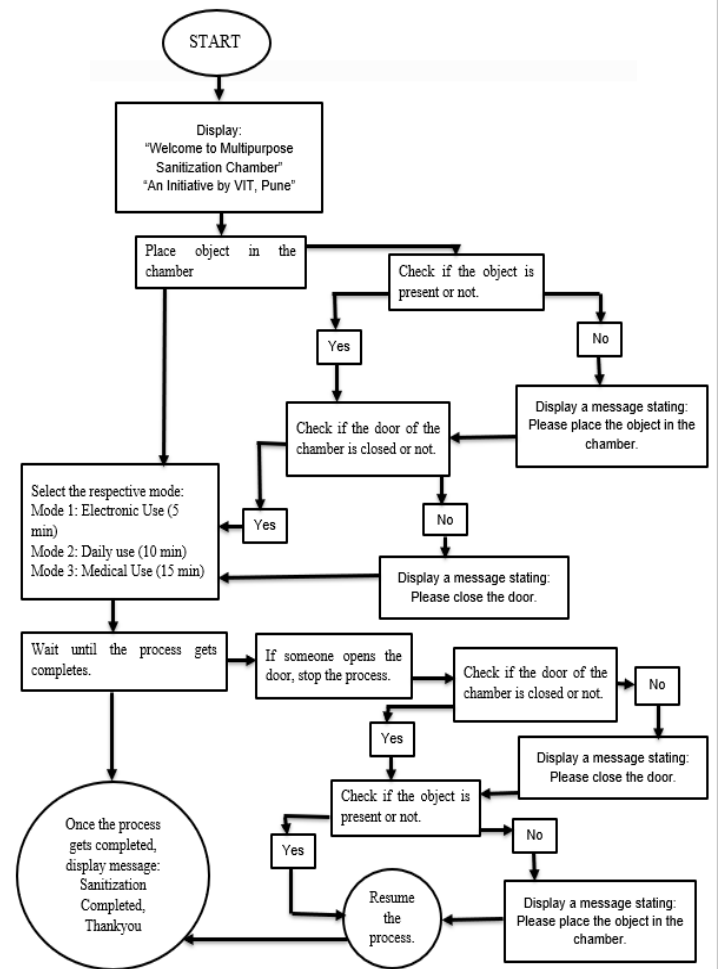

Fig. 8 System Flowchart of the system

2.4 Working Methodology



Fig. 9 Closed view of Multipurpose Sanitization Chamber

The working of the following chamber ‘Multipurpose Sanitization Chamber’ as shown in Fig. 9 is explained below:

The Multipurpose Sanitization Chamber has three different sanitizing modes. Firstly, the ultrasonic sensor detects the presence of items or objects placed in the chamber and then the door sensor checks the condition of the door. Once the item or object is detected and the condition of the door is close, it allows the user to select the respective mode. If the user needs to sanitize electronic gadgets, then the user will select the electronic mode i.e., Mode 1, which will sanitize the item or object for 5 minutes using UVC light. The wavelength of UVC light is 253.7nm. If the user needs to sanitize daily items, then the user will select daily use mode i.e., Mode 2, which will sanitize the items or object for 10 minutes using UVC light for 8 minutes and mist for 2 minutes. If the user needs to sanitize medical items or those items or objects which requires deep sanitization, then the user will select medical mode i.e., Mode 3, which will sanitize the items or object for 15 minutes using UVC light for 8 minutes, heat for 5 minutes and mist for 2 minutes. If in between the ongoing process, user tries to open the door the process will stop there itself, and will ask the user to close the door, once the door is closed, it will again check the objects and resume the process from where it was stopped. The chamber is provided with a partition so that it becomes feasible and easy for the user to sanitize many items or objects simultaneously. This partition can be removed easily also. These modes can significantly prevent viral infection on treated clothing, electronic devices, veggies, and any other exposed body surface. The chamber has automatic guidance through the use of a display. [9].

4. RESULTS AND DISCUSSIONS

After implementation of hardware and software system is checked for its performance which is explained in the following paragraph. As shown in Fig. 10, the circuit consists of Arduino Uno as microprocessor, 16*4 LCD display, 5V 8-channel Relay Module, 4 pushbuttons.

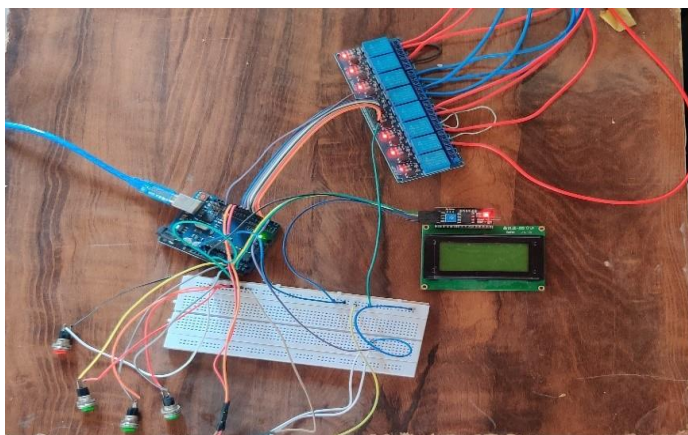

Fig. 10 Circuit Diagram

Powering the Chamber by the owner, which will display welcoming messages on the LCD screen “Welcome to Multipurpose Sanitization Chamber”, “An Initiative by VIT College” is shown in Fig. 11, Fig. 12.



Fig. 11 Displays welcoming message “Welcome to Multipurpose Sanitization Chamber” on LCD screen

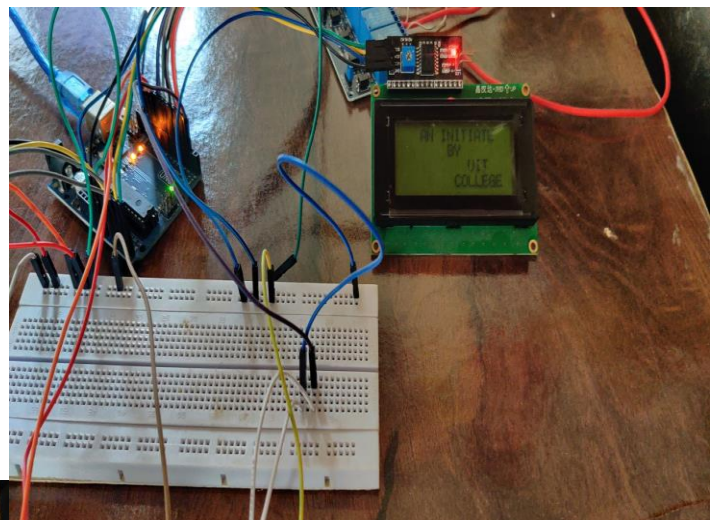

Fig. 12 Displays welcoming message “An Initiative by Vit College” on LCD screen

The user then needs to select the Mode of sanitization by pressing the respective button as shown in Fig. 13. Before starting the respective process for sanitizing the item/object, the system will check three conditions, and if those conditions are satisfied then only the system will start the process. The three conditions are checked by the system that are: 1) the door should be closed, and item/object should be placed in the chamber, 2) if door is closed and item/object is not placed in the chamber then the process won’t start, and 3) if door is open and item/object is placed in the chamber then also the process won’t start.

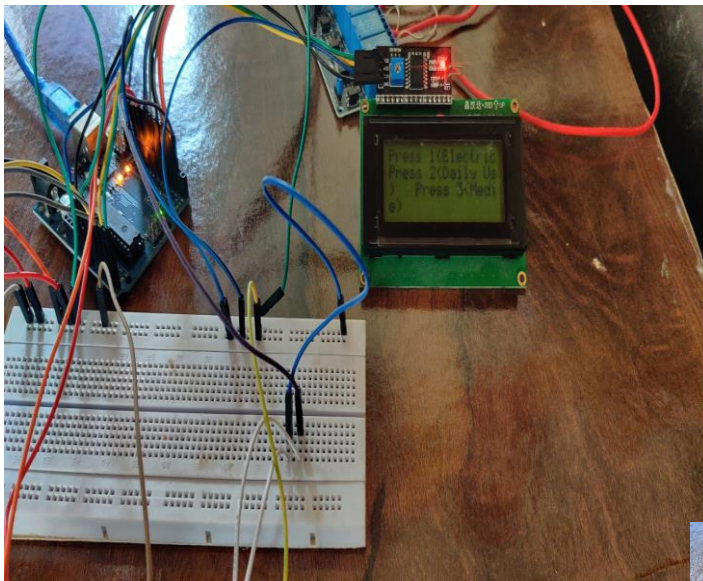

Fig. 13 Modes for sanitizing items/objects

Fig. 14, Fig. 16 and Fig. 18 shows the first, second and third mode of sanitization which will get started when the user presses button 1 for mode 1, button 2 for mode 2 and button 3 for mode 3.

The user will be intimated by displaying message on the LCD screen when each method is completed as shown in Fig. 15, Fig. 17 and Fig. 19.

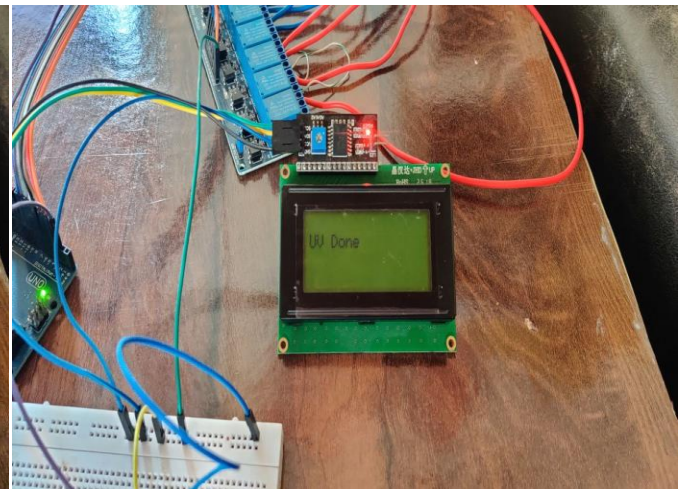

Fig. 15 Mode 1 completed

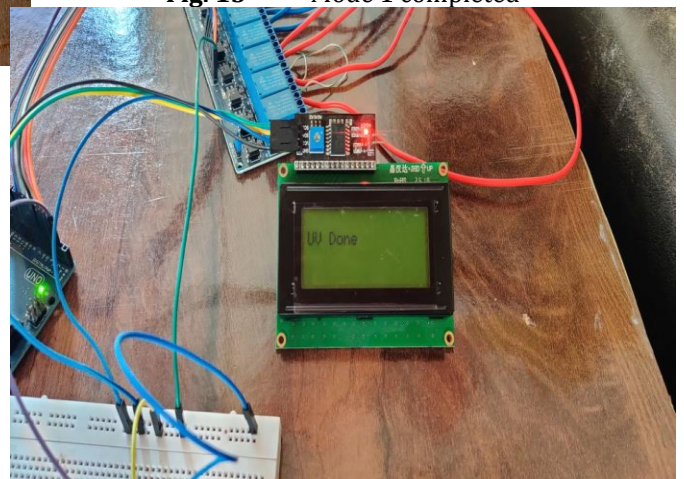

Fig. 16 Mode 2 selected

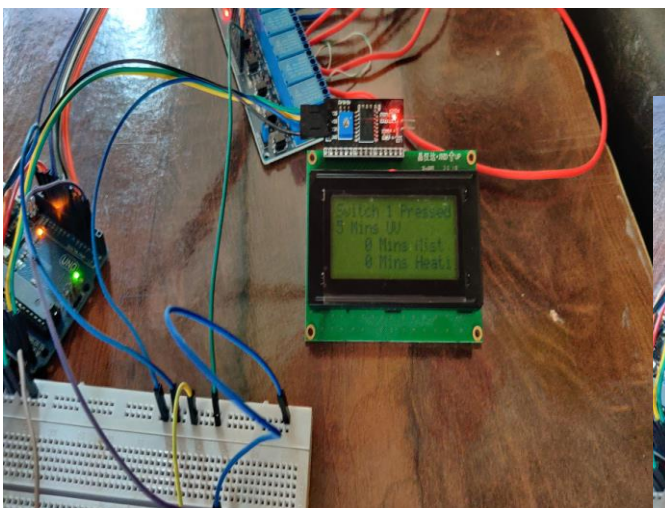

Fig. 14 Mode 1 Selected

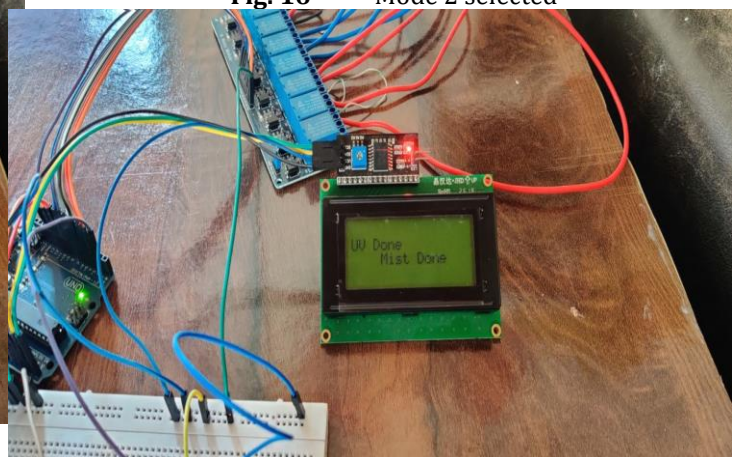

Fig. 17 Mode 2 completed

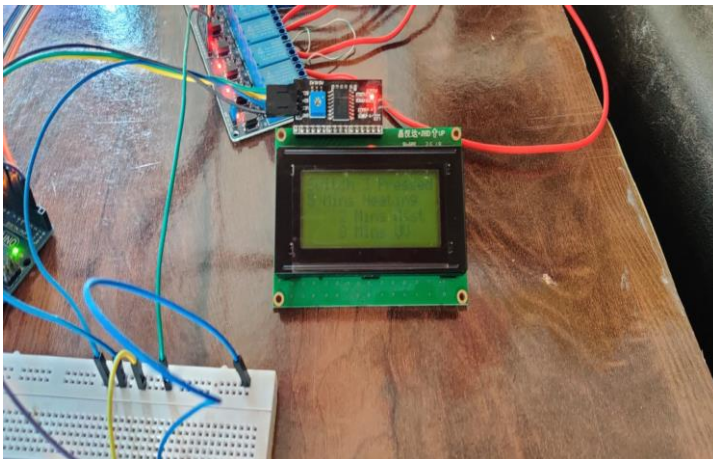

Fig. 18 Mode 3 selected

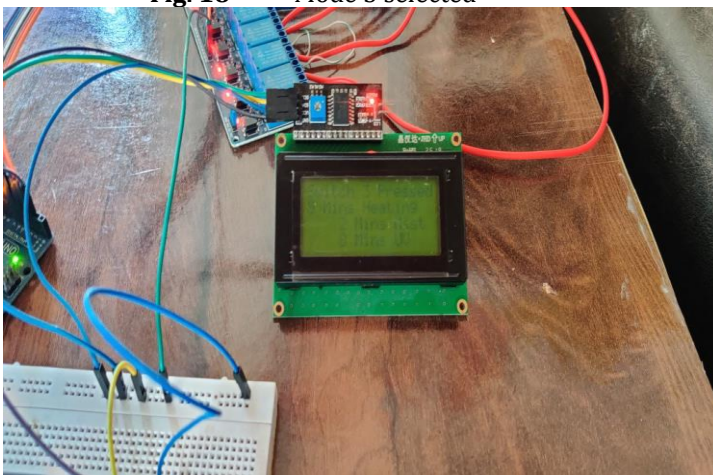

Fig. 19 Mode 3 completed

Also, if the user tries to open the door in between the system, then the system will get paused there only for safety reasons, and the user will be asked to close the door and once the user closes the door, the system will again check the three conditions and if they are satisfied it will resume the process.

5. CONCLUSION

The proposed Multipurpose Sanitization Chamber is developed with an intention to neutralise the effect of Corona virus by exposing it to three different sanitizing modes and by using three different sanitization time period. Also, while developing this chamber the safety of the user is kept in mind like exposure to UV-C light which may cause various health issues to the user. This chamber is offering many advantages like low cost, separable section, user's safety, easy to move from one place to other, selection of different mode depending upon the item/object to be sanitized. This chamber will sanitize and disinfect item/object and will reduce the chances of user to contradict to the virus.

ACKNOWLEDGEMENT

The success and the outcome of this project required a lot of guidance and support. I thank my team members Manasi Mane and Swapnil Mane for their continuous support and involvement. I also thank our faculty of Instrumentation Department of our Vishwakarma Institute of Technology, Pune for their guidance and appreciation.

REFERENCES

- [1] Cleaning and disinfection of environmental surfaces in the context of COVID-19; 2020 (<https://apps.who.int/iris/bitstream/handle/10665/332096/WHO-2019-nCoV-Disinfection-2020.1-eng.pdf?sequence=1&isAllowed=y>). M. Young, The Technical Writer's Handbook. Mill Valley, CA: University Science, 1989.
- [2] Maurya, D., Gohil, M.K., Sonawane, U. *et al.* Development of Autonomous Advanced Disinfection Tunnel to Tackle External Surface Disinfection of COVID-19 Virus in Public Places. *Trans Indian Natl. Acad. Eng.* 5, 281–287 (2020). <https://doi.org/10.1007/s41403-020-00141-7>
- [3] Das, Hirak & Bhatia, Dinesh & Das, Kalyan & Mishra, Animesh. (2020). Development of Vioreaper sanitization chamber for COVID 19. *Sensors International*. 1. 100052. 10.1016/j.sintl.2020.100052.
- [4] Y. Ma, Y. Zhao, J. Liu, X. He, B. Wang, S. Fu, B. Luo, Effects of Temperature Variation and Humidity on the Death of COVID-19 in Wuhan, China, *Science of the Total Environment*, 2020, <https://doi.org/10.1016/j.scitotenv.2020.138226>, 138226.
- [5] SCTIMST scientists develop disinfection gateway & facemask disposal bin to fight COVID-19 | Department Of Science & Technology. <https://dst.gov.in/sctimst-scientists-develop-disinfection-gateway-facemask-disposal-bin-fight-covid-19>.
- [6] Wang J, Tang K, Feng K, Lv W (2020) High temperature and high humidity reduce the transmission of COVID-19. *SSRN Electron J*. <https://doi.org/10.2139/ssrn.3551767>
- [7] Agarwal, Krishna & Mohapatra, Swati & Sharma, Prairit & Sharma, Shreya & Bhatia, Dinesh & Mishra, Animesh. (2019). Study and overview of the novel corona virus disease (COVID-19). *Sensors International*. 1. 10.1016/j.sintl.2020.100037.
- [8] Dinesh Bhatia, "Innovations to Provide Relief to Common Man during COVID 19 Crisis", Highland Post Newspaper, Shillong, 31st May 2020
- [9] [http://pericles.ipaustralia.gov.au/ols/auspat/quickSearch.do?queryString=2021103619&resultsPerPage=\(Patent No: 2021103619\)](http://pericles.ipaustralia.gov.au/ols/auspat/quickSearch.do?queryString=2021103619&resultsPerPage=(Patent No: 2021103619)).