

Fair Model for Electricity Billing and Sharing in Shared Apartment in Ghana

Anyam Justice¹, Frimpong Theophilus², Isaac Kofi Otchere³, Bernard Arhin⁴

¹ Department of Computer and Electrical Engineering

² University of Energy and Natural Resources-Sunyani, Ghana

Abstract - This paper proposes a smart monitoring system for determining individual energy consumption in a shared apartment with a single energy meter. The smart energy monitor was designed using Arduino Uno, SIM800L GSM Module, PZEM004T energy metering device, I2C LCD, RTC and Current Transformer. The purpose of the proposed system is to help resolve the problem of bill sharing in a shared apartment that shares a common energy meter. The system was built on a meter board consisting of the monitoring section and the load section. The program for the system was carried out with Arduino IDE in C language with Arduino syntax. The proposed method of determining energy consumed for individual rooms in a shared apartment using the smart energy monitor was put to test. The smart energy monitor was able to display energy consumed and the amount to be paid by two tenants on an LCD display while sending an SMS notification to the consumers.

KEY WORDS: Arduino, Energy Metering device (PZEM-004T), Global System for Mobile communication (GSM), Real time, Short Message Services (SMS).

1. INTRODUCTION

A shared apartment is mainly a cluster of buildings in an enclosure having a shared or associated purpose. It is one of the famous housing settlements in Ghana mostly common in rural areas. They are occupied by external family members or individuals with different backgrounds. They usually take the shape of U, L or completely enclosed. The rooms are for the most part a single room or two rooms (otherwise called chamber and hall). Tenants share an overall washroom, and they alternate in cleaning it [1]. The latrines are not by any means the only place the tenants share; they additionally share a public water source and now and again an electrical meter. Shared apartments are utilized now for business purposes. The rooms are leased to people who look for cover in rural and metropolitan areas. These people are referred to as tenants and the owner of the structure as the Landlord/Landlady. A shared meter in shared apartments is a common situation in Ghana. Nonetheless, this accompanies its issues. The unpaid debts of electrical bills are collected and shared among tenants. Research on Poverty and Social Impact evaluation (PSIA) for Ghana's energy expressed a challenge for tenants in shared apartments. The challenge is monitoring which extent of overdue debts of electrical bill belongs to a tenant in a shared apartment [1]. The issue

achieves such countless vulnerabilities and correspondingly cause distress between the tenants and their Landlords.

Tenants find it difficult to go to an agreement on the standing of electrical bill-sharing. The monthly electricity bills are shared among the tenants by the mostly used technique known as the agreed point system. Often the lighting points and sockets are counted as the bases for determining the number of points that a tenant consumes, and the bill is shared according to the ratio of points of all tenants. Looking at this practice from a more technical view, you would realize that there are flaws with this practice. For instance, the appliances that one tenant uses may vary from one another. A tenant using a fluorescent bulb with 40W rating may be assigned the same point as a tenant using an incandescent bulb with or over 100W rating. The conclusion that can be drawn here is, there are two different tenants both using a bulb but clearly, the rating of one of the bulbs is higher than the other. This type of situation leads to unfairness in the sharing of bills which can probably result in a lot of disputes among tenants [1]. This kind of issue will continue to persist since all tenants are hooked to the same energy meter. To help deal with such issues that emerge with regards to energy bill sharing in shared apartments, a smart monitoring system have been proposed. The smart monitoring system would help to fairly share the amassed overdue debts with ease depending on the measure of power consumed by each tenant. A number of research work on smart energy consumption monitoring have been carried out in recent years. A smart energy monitoring system, designed to replace the conventional meter reading method was proposed in [2]. They made use of an energy metering IC, a liquid crystal display, GSM modem and a microcontroller.

The goal was to read electricity consumed, calculate electricity consumption at a billing point sever on the side of the energy provider and send an SMS to the consumer on amount they are required to pay. Another similar system was designed by D.V.N Ananth and his team to resolve issues related to monitoring energy consumption [3]. Their system was based on IOT based smart electricity meter which makes use of Node-Microcontroller unit (Node- MCU), Energy meter, current sensor and voltage regulator. The Node-MCU is connected to a blynk app interface which is an IOT based platform used to control Node-MCU. This allows the consumer to monitor their energy consumption through the blynk app. Another approach related to electricity billing

using using GSM based automatic electricity billing system was introduced in [4]. This system was designed using a microcontroller, GSM module, buzzer, LCD display and relay switch. Two GSM module were used, one connected to the energy meter and the other attach to PC located at the EC office. The system accumulates the power consumption at the end of every month after which a GSM receiver sends information wirelessly to GSM connected to the office and the user. In the case where a consumer fails to pay their bills on time the power supply to the consumer is disconnected.

This paper utilizes the smart energy monitoring implementation methods discussed in the various literatures to propose a fair energy bill sharing system for shared apartment residents with a single energy meter. The paper is organized as follows: Section 2 highlights briefly the composition of the hardware and software section of the project. A detail description of the hardware components used for the project are introduced in Section 3. Software implementation is discussed in Section 4 with performance analysis of the smart energy monitoring system and summary given in Section 5 and 6 respectively.

2. COMPOSITION OF THE SMART ENERGY MONITORING AND BILLING SYSTEM

The hardware components for implementation of the smart energy monitoring and billing system includes Arduino UNO (Fig. 1 & Table 1), Pzem-004T energy metering device (Fig. 2,3 and Table 2), current transformer, LCD display, etc.

The selection of the hardware components for the project was largely based on low cost, availability and its durability. The different connections for the hardware was made depending on some key sections which include the power system, the micro-controller and the communication interface. Connections was obtained from the datasheets of the selected components. For the power system, the perfect measure of voltage supplied to the microcontroller was 12 V and while the GSM module took 4V. As for the software part, all the program was carried out using Arduino UNO supported by C language. Arduino UNO act as the main controller which connect the energy meter, GSM module, and other sensors or peripherals to establish communication among them

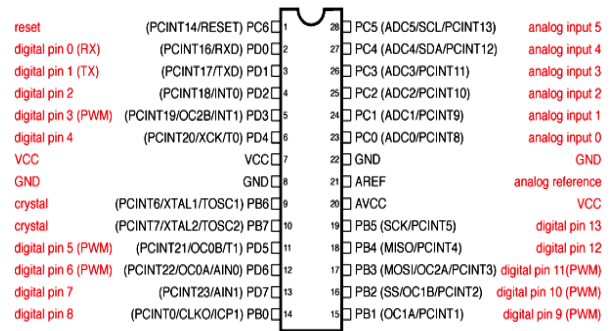

Fig -1: Arduino Uno to ATmega328 Pin Mapping

Table -1: ARDUINO UNO PINOUT CONFIGURATION

Pin Category	Pin Name	Details
Power	Vin, 3.3V, 5V, GND	Vin: Input voltage to Arduino when using an external power source. 5V: Regulated power supply used to power microcontroller and other components on the board. 3.3V: 3.3V supply generated by on-board voltage regulator. Maximum current draw is 50mA. GND: ground pins.
Reset	Reset	Resets the microcontroller.
Analog Pins	A0 – A5	Used to provide analog input in the range of 0-5V
Input/Output Pins	Digital Pins 0 - 13	Can be used as input or output pins.
Serial	0(Rx), 1(Tx)	Used to receive and transmit TTL serial data.
External Interrupts	2, 3	To trigger an interrupt.
PWM	3, 5, 6, 9, 11	Provides 8-bit PWM output
SPI	10 (SS), 11 (MOSI), 12 (MISO) and 13 (SCK)	Used for SPI communication.
Inbuilt LED	13	To turn on the inbuilt LED
AREF	AREF	To provide reference voltage for input voltage.

3. HARDWARE DESIGN

The hardware section of the project is depicted in Fig. 4 which details the structure of the proposed energy monitoring system used for collecting data about energy consumption. The role of the various hardware components used is detailed as follows.

3.1 Hardware Components

One of the key components used for the project is the current transformer. The current transformer scales an enormous current to smaller current level that can easily be measured safely. The current transformer used for the project is capable of measuring up to 100A of current [5], which is the most extreme current level allowed in residential homes. The microcontroller used is the Arduino UNO. It is an integrated circuit (IC) device used for controlling or running a predefined task in an electronic circuit [6]. It is responsible for processing data from the metering device. The Pzem-004T module is an energy metering device for measuring voltage, current, power and energy consumption of a load using Arduino. An I2C LCD 16x2 display was selected because of its ease of use and availability. Its main function was to display tenants' electricity consumption. An SIM800L GSM module was used to perform communication task. It is a miniature cellular module which allows for GPRS transmission, sending and receiving SMS. It can also be used for receiving voice calls [7]. The GSM with some programming sends alert in the form of text messages to the tenant to inform them about the amount of energy consumed and how much they are required to pay. The DS1302 is a clock device programmed to keep track of time and date. Another important component used was the push button. The push button was incorporated in the hardware setup to reset energy readings to zero after it has been pressed. The objective was to allow the monitoring system to initiate a new computational task for the upcoming month. A buck converter was also used in the project to lower the input voltage of an unregulated DC supply to a stabilized lower output voltage [9]. In this project, the buck converter was used to step down 12V DC input to a 4V DC output to power the GSM. Since the components depends on both AC and DC supply, a 12V DC power supply which takes AC input was used to power the microcontroller which in turn power the other DC components on the system.



Fig -2: PZEM-004T module

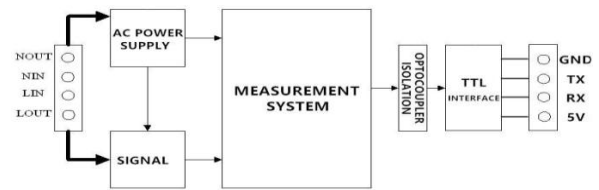

Fig -3: PZEM-004T module functional block diagram

Table -2: PZEM-004T MODULE SPECIFICATION

Function	Measuring range	Resolution	Accuracy
Voltage	80~260V	0.5%	0.5%
Current	0~10A 0~100A	0.01A 0.02A	0.5%
Active power	0~2.3kW 0~23kW	0.1W	0.5%
Active energy	0~9999.99kWh	1Wh	0.5%
Frequency	45~65Hz	0.1Hz	0.5%
Power factor	0.00~1.00	0.01	1%

3.2 Operation of the Hardware Setup

As shown in Fig. 4, the system is supplied with a single phase 230V AC which flows through a connector to the various loads (L1 and L2). On the load lines is a current transformer (CT1 and CT2) which measures the current being consumed by the various loads and output it to the energy metering devices (PZEM 1, PZEM 2). The 230V AC is also supplied to the 12V dc power supply which takes AC as its input which is then used to power the microcontroller. A DC-DC buck converter is placed between the GSM and the 12V DC power supply circuit which takes the 12V DC as its input and step it down to 5V DC to power the GSM. The RTC on the system is used to track time and date. The LCD displays the data processed from the microcontroller. All these devices are connected to their respective pins on the microcontroller. The communication between the energy metering devices (PZEM 1, PZEM 2) is established through pin 12, 13, 4 and 5 on the Arduino Uno where data such as measured currents and voltages are sent to the microcontroller for energy computation.

The microcontroller also sends back its computed parameters to the metering devices to store the energy value. The microcontroller also communicates with the GSM through pin 10 and 11 for the GSM to send the energy consumption of the individual tenant through text message at the end of each month. The microcontroller also ensures the energy being accumulated are displayed by the LCD in real time.

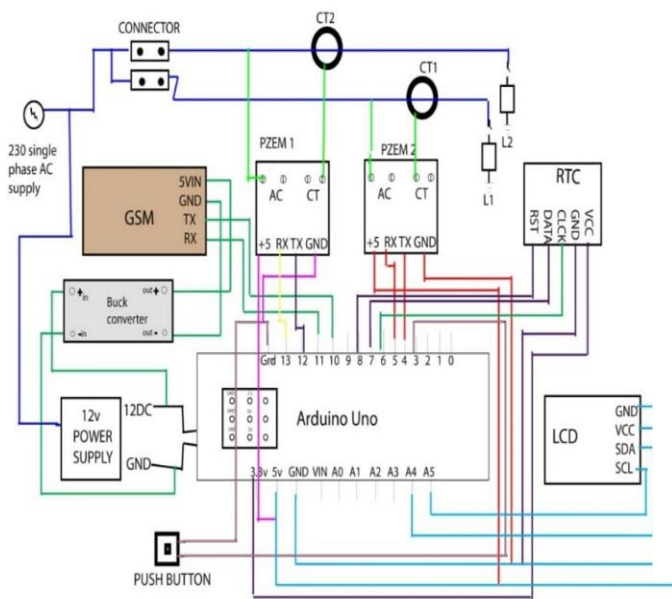

Fig -4: Schematic diagram of the smart energy monitor

The push button is for manual reset in case there is network issue and the GSM fail to send the message at the end of the month, one can check on the LCD screen its energy consumption for that month and push the button to reset the energy reading to zero for it to restart the computation for the next month. The hardware design was completed by assembling the various components on meter board with the metering on one side and the load on the opposite side.



Fig -5: Connection of metering and load end

4. SOFTWARE DESIGN

The flow chart for the programming logic of the project is depicted in Fig 6. After completing the various tasks in the hardware setup which include the supply of electric power to energy meter and connection of current transformer to the appropriate room wire the measured values by the metering device is relayed to the micro-controller. The microcontroller computes the energy, sends the computed energy value to the GSM module and the LCD.

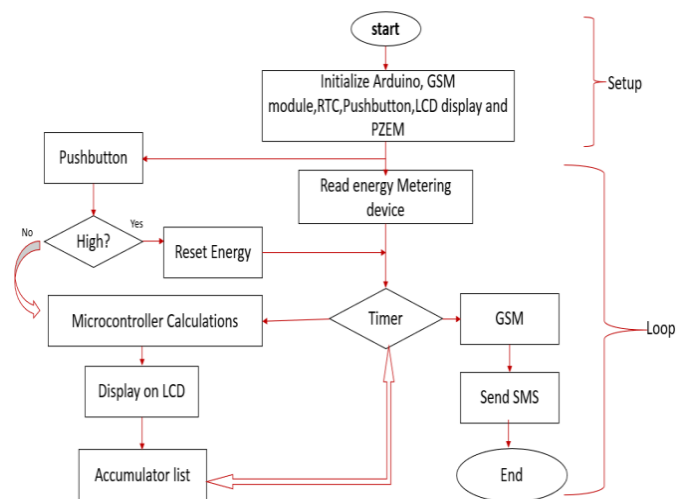

Fig -6: Flowchart for programming the system

The GSM sends SMS to the end user as an alert. The program was written to achieve the project’s main objectives which were to carry out the energy computation and relaying of SMS notification through the SIM800L GSM module. Observing the flow chart in Fig. 6, the components to be programmed were initialized. Components such as the GSM, RTC, LCD, pushbutton and energy metering device were all initialized. The library used for this project were the LiquidCrystal I2C.h, SoftwareSerial.h, Sim800L.h, virtuabotixRTC.h for the RTC and PZEM004Tv30.h for the energy metering device. The LCD was programmed to display the room number, time and date, power and energy being consumed at the end of the month. The Fig. 7 shows the snapshot of the Arduino LCD code for displaying the required parameters.

```

myRTC.updateTime();
myLcd.clear();
myLcd.setCursor(0,0);
myLcd.println("Date: ");
myLcd.print(myRTC.dayofmonth);
myLcd.println("/");
myLcd.print(myRTC.month);
myLcd.println("/");
myLcd.print(myRTC.year);
myLcd.setCursor(1,1);
myLcd.println("Time: ");
myLcd.print(myRTC.hours);
myLcd.println(":");
myLcd.print(myRTC.minutes);
myLcd.println(":");
myLcd.println(myRTC.seconds);

delay(100);

myLcd.clear();
myLcd.setCursor(0,0);
myLcd.println("R1");
myLcd.setCursor(4,0);
myLcd.print("Pow:"); myLcd.print(p); myLcd.println("W");
myLcd.setCursor(0,1);
myLcd.print("Energy:"); myLcd.print(e,3); myLcd.println("
delay(15000);

myLcd.clear();
myLcd.setCursor(0,0);
myLcd.println("R2");
myLcd.setCursor(4,0);
myLcd.print("Pow:"); myLcd.print(p2); myLcd.println("W");
myLcd.setCursor(0,1);
myLcd.print("Energy:"); myLcd.print(e2,3); myLcd.println("
delay(15000);
    
```

Fig -7: Extract of LCD display code for Date, time, power and Energy

Also, the code for sending SMS informing the tenants their energy consumption and bill for the month is shown in Fig. 8. The code for resetting energy computation to zero at the end of a month upon activation of the push button is shown in Fig. 9.

```
// A function to send a text message to the individual tenant
void SendTextMessage(String number, String text){

  Sim.println("AT+CMGF=1"); // Configuring TEXT mode
  delay(100);
  Sim.println("AT+CMGS=\""+ number +"\r");//change ZZ with country code and xxxxxxxxxxxx with phone number to sms
  delay(100);
  Sim.print(text); //text content
  delay(100);
  Sim.println(char(26));
  delay(100);
}
```

Fig -8: Code extract for sending SMS to tenants

```
// A conditional statement to reset Accumulated energy consumption to zero when the push button pressed
boolean jet = digitalRead(pushPin);
if(jet==0){
  pzem.resetEnergy();
  pzem2.resetEnergy();
}
```

Fig -9: Code extract for push button

The Real-time clock (DS1302) was used to keep track of real time measurements. For every 720hrs (30 days) an SMS is automatically sent to the tenants. The average number of days in a month is about 30 days, and when 30 days is multiplied by 24 hours, the output is 720hrs. For this project, the RTC was programmed so that after every 1hr an SMS was sent to the user.

5. RESULTS AND DISCUSSION

The interface for the monitoring system was categorized into two major sections which were the energy meter interface and the GSM module interface. Circuit operation was in good condition with the right sequence of operation after it was uploaded onto the microcontroller. The system was further tested to assess its performance. However, some parameters could not be displayed on the LCD because the LCD could display only two parameters on its two rows. The parameters that were shown were date, time, the room number, the power and the energy consumption at the end of the month. The SMS was also sent to two different people informing them about their electricity bill. The bill was calculated based on the Electricity company of Ghana rate of charge per kilowatt-hour energy used and an SMS was sent at the same time to the two different people acting as the tenants.



Fig -10: Date and Time being displayed on the LCD

The results show tracking and displaying of time and date on the LCD. Messages were sent and individual energy consumption were all displayed base based on the timer.



Fig -11: Results being displayed on LCD for Room 1

As shown in Fig. 11 the tenant in room one was using energy up to 6.31kWh. Fig 12 also shows the SMS that was sent to the tenant in room one.

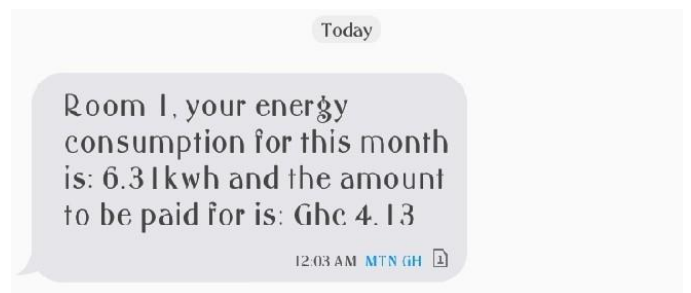

Fig -12: SMS sent to tenant in room 1

The SMS sent to tenant one contains information about the amount of energy that has been consumed and the payment to be made in Ghana cedi. Fig 13 and 14 shows the LCD display for tenant two and the SMS received respectively.



Fig -13: Room 2 LCD display

From the computed energy values the tenant in room two is using energy up to 15.254kWh which is sent as SMS notification to the tenant in room two.

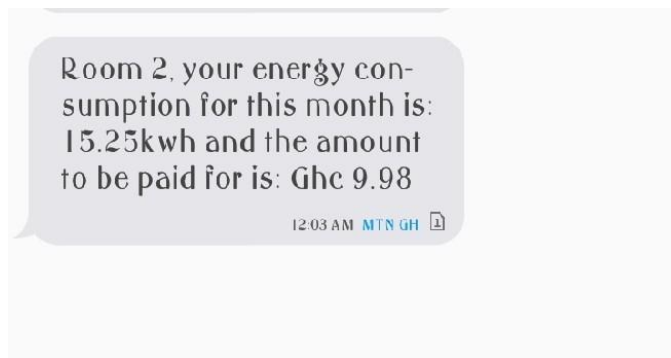

Fig -14: SMS sent to tenant in room 2

In the same case as the first tenant, the SMS is sent to tenant two to notify him on the amount of energy consumed and the amount to be paid for in Ghana cedi. The test results give an insight about the energy consumption variation between the two consumers. From the recorded energy values, tenant in room two had a more load than in room one. The energy used in room one was only 6.310kWh at the end of the month while room two used 15.254 kWh in after a month. For this reason, it's fair that tenant in room two pays more than the tenant in room one. The display of consumer's energy consumption on an LCD and through SMS notification can help prevent unfair bill sharing among tenants in a shared apartment with a single energy meter.

6. CONCLUSION

An effective approach for eliminating an unfair bill sharing among tenants living in a shared apartment with a single energy meter in Ghana have been discussed in this paper. To help resolve bill related problems, this paper proposed a method of obtaining energy consumed by each tenant in a shared apartment using a smart energy monitor. The smart energy monitor acquires the energy consumed by each tenant and display it on an LCD while an SMS is sent to each tenant informing them about their energy consumption and the amount they had to pay in Ghana cedi at the end of

every month. The smart energy monitor was designed using components such as Arduino Uno, SIM800L, Current transformer and PZEM004T, 16x 2 I2C LCD, a DS1302 (RTC) etc. Programming was carried out in C language in Arduino syntax. The proposed system setup was able to carry out tasks as expected, which is displaying calculated energy consumption on an LCD and sending SMS notification to tenants or consumer. The smart energy monitor was designed with the assumption that the wiring of the rooms was separated. Meaning each room's wire connections was independent of the other room. Simple house wiring is not usually the case; some places are not separately wired. As a result, future work related to smart energy monitoring will focus on houses with different wiring, especially those with single wiring connections.

REFERENCES

- [1] M. o. E. P. S. C. Government of Ghana, "Ghana Poverty and Social Impact Analysis, Electricity Tariffs: Phase I," 2004. H. Simpson, *Dumb Robots*, 3rd ed., Springfield: UOS Press, 2004, pp.6-9.
- [2] A. K and S. George, "GSM Based Automatic Energy Meter Reading System with Instant Billing", ResearchGate, 2013. J.-G. Lu, "Title of paper with only the first word capitalized," *J. Name Stand. Abbrev.*, in press.
- [3] D. V. N. Ananth, G. Joga Rao Ch. Satish3, J. Shyam4, K.Santosh, U.V.V.S.S.V.Prasad, K. Ramya "Smart Electricity Billing Using Node- MCU", ResearchGate, 2019.
- [4] Ananth, Christo & Kanthimathi, & Krishnammal, & Jeyabala, & Monika, Jothi & Veni, Muthu. (2015). GSM Based Automatic Electricity Billing System. International journal of advanced research trends in engineering and technology. 2. 16-21. 10.2139/ssrn.3026891.
- [5] Introduction to Current Transformers. Elkor Technologies, Jul. 05, 2006.
- [6] Microcontroller unit, Available at: <https://www.allaboutcircuits.com/technical-articles/what-is-a-microcontroller-introduction-component-characteristics-component/>.
- [7] Mini GSM/GPRS module, Available at: <https://nettigo.eu/products/sim800l-gsm-grps-module>.
- [8] Arduino Uno, Pushbutton Tutorial Available at: <https://docs.arduino.cc/built-in-examples/digital/Button>
- [9] An Introduction to Buck, Boost, and Buck/Boost Converters, Available at: <https://recom-power.com/en/rec-n-an-introduction-to-buck-boost-and-buck!sboost-converters-131.html?0>