

# Energy Conservation Bidirectional visitor counter

Samiksha Wani<sup>1</sup>, Shashikant Dhutraaj<sup>2</sup>, Prajwal Raut<sup>3</sup>, Rutika Jambhulkar<sup>4</sup>, Vinay Thool<sup>5</sup>

Guide: Dr. Bhupendra Kumar Asst. Professor, Dept. of Electrical Engineering, G.H.Raisoni Institute of Engineering & Technology, Maharashtra, India.

\*\*\*

**Abstract** - This paper deals with the Bidirectional Visitor Counter with automatic light and fan control. In this paper a system designed wherein the number of persons entering or leaving a room is kept track of and displayed on a LCD screen. To turn on and turn off, light, fan, other electrical equipment according to human presence in room with respect to light intensity & room temperature. When a person enters the room, count would be increased, whereas on leaving, the count would decrease. IR sensing mechanism is used to sense the entry & exit of visitors and the whole counting operation is done by a microcontroller. When somebody enters the room then the counter is incremented by one (+1) and when any one leaves the room then the counter is decremented by one (-1). The total number of persons inside the room is also displayed on the LCD (Liquid Crystal Display). The microcontroller is used for detecting an entry or exit action. Therefore, system would take care of electricity and display count of visitors available in room.

**Key Words:** Energy conservation, Voltage Regulator, Bidirectional sensors.

## 1. INTRODUCTION

This paper brings the advantages of technology into the homes of people by automating their household and to provide a solution to prevent wastage of electricity and thus help in overcoming the problem of scarcity of electricity. This Project is designed to detect person entering into the room or leaving the room. In this project written program for up and down counter which is also displayed on seven segment display. If number of persons present in a room is equal to zero then all lights and fan will get OFF automatically thus saving power. This project "automatic room light controller with visitor counter using microcontroller" is a reliable takes over the task of persons/visitor in the room very accurately. When somebody enters into the room will be switched ON and when any one. The light in room will be only switched OFF until all the persons in the room go out. The total number of person inside the room also displayed on the seven segment displays.

## 1.1 Objective

The primary objectives of this project are:

- Using an Arduino Nano, IR sensor, relay and a battery, create a bi-directional visitor counter that will display its statistical output on an LCD screen.
- Ensure that the system functions effectively.
- To create a system that will automatically notify you of the precise number of people who enter or exit a restricted area.
- To create a system that can count the total number of people in a small space without the need for human intervention.
- To create a system that can automatically monitor a location's attendance and aid in emergency planning and budgeting.

Finally, complete content and organizational editing before formatting. Please take note of the following items when proofreading spelling and grammar:

## 1.2 Methodology

The methodology of Digital Bidirectional Visitors Counter (DBVC) is discussed in this section, beginning with a system overview of each component that is used to assemble the guest counter in order to facilitate efficient crowd management, also known as monitoring and controlling. The guest counter, which is based on an Arduino, is designed to respond to errors in counter executions that have already occurred. The four main sections and circuits of the design are discussed in their true sense. The power supply circuitry, detection section (IR sensor), Arduino section, and the displaying section (LCD) are all included in this.

## 2. Schematic Diagram of Bidirectional Visitor Counter:

The schematic diagram of the bidirectional visitor counter is given in Figure 1, where all the components are connected to each other systematically.

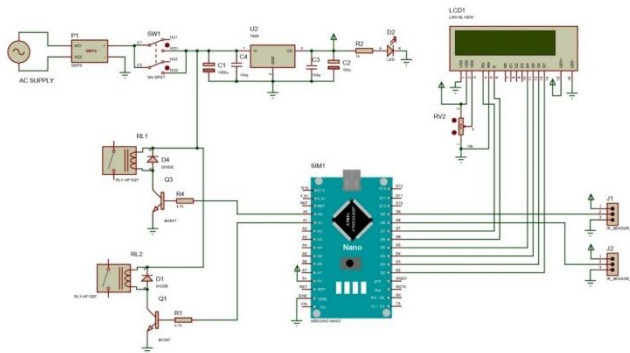

Figure 1 Schematic Diagram of model

**Power Supply Section**

The power supply stage supplies the necessary DC voltage to ensure that the circuit's components, particularly the Active ones, are powered appropriately. The supply for the circuit is +5VDC. Rectifier is a step-down transformer that is used in the linear power supply stage. The regulated DC voltage is provided by a filter capacitor and voltage regulators.



Figure 2 IR Sensor

An electronic device known as an infrared (IR) sensor as shown in Figure 2 measures and detects infrared radiation in its immediate environment. When an object approaches the sensor, the LED's infrared light reflects off of the object and is picked up by the receiver.

IR sensors are now widely used in motion detectors, which are used in building services to turn on lights and alarm systems to find guests who aren't welcome. In this model, the sensor elements detect the heat radiation (infrared radiation) that changes over time and space as a result of people's movement within a predetermined angle range.

**LCD Display:**

Electronic display modules with a wide range of uses include LCD (Liquid Crystal Display) screens as shown in Figure 4. A very fundamental module, a 16x2 LCD

display is utilized frequently in numerous circuits and devices. A 16x2 LCD is capable of displaying 16 characters on each of two lines. Each character is displayed in a 5x7 pixel matrix on this LCD. 24 distinct characters and symbols can be displayed on the intelligent 16 x 2 dot matrix display. The Command and Data registers on this LCD are its two registers.



Figure 3 LCD Display

**Result**

The following are the obtained results of the bidirectional visitors counter. The model was successfully built and was easily portable as shown in Figure 5.



Figure 4 Developed model

1. In showing of the venture, the infrared detecting part used to recognize the section of guests worked.
2. Microcontroller was extremely proficient in its errand execution, hence calculation of counts and controlling I/O gadgets.
3. Likewise, the LCD, the buzzer was successful in cautioning and notices.
4. By reducing the rate of error when counting visitors, the proposed system will count visitors more effectively and efficiently.

- The purpose of this device's design and construction was to precisely count and display the number of people in a room or other location.
- The setup of the model was portable and can easily be installed at any place.
- At the point when someone goes into the room then the counter will be incremented appropriately the lights in the room will be turned ON and when any one leaves the room then the counter will be decremented.

**Table 1 Results of Bidirectional Visitors Counter with count of person and lights and fan in a room.**

INPUT	OUTPUT
Person present in a room	Count - 1 Turned ON - Light Turned ON - Fan
Person absent in a room	Count - 0 Turned OFF - Light Turned OFF - Fan

### Conclusion

This project has succeeded in achieving its goal. Arduino Nano served as the primary controller for the successful design and implementation of a bidirectional visitor's counter. At the restricted location, the designed system functions flawlessly as a counter. The visitor can be identified by the microcontroller regardless of whether they are entering or leaving the room.

The LCD (Liquid Crystal Display) displays on the system show the total number of people visiting the restricted area. The display shows how many people enter the area, how many people leave the area, and the difference between those who enter and those who leave. A program that counts visitors ascending and descending through a specific entrance or passageway is working well.

The construction was carried out in such a way that it is simple to carry out maintenance and repairs and reasonably priced for the user in the event of a system failure. We've learned a lot about practical electronics through the project, which is one of the biggest challenges we'll face in this field now and in the future. The variable power supply design required extensive research and labor.

This work's design, analysis, and construction all required extensive work. Although the project was time-consuming and difficult, it was ultimately successful.

However, as with every aspect of engineering, the project still has room for improvement and research.

### References

- Automatic room light intensity detection and control using a microprocessor and light sensors, Ying-Wen Bai; Dept. of Electron. Eng., Fu-Jen Catholic Univ., Taipei; Yi-Te Ku.
- Reference Book: Programming in ANSI C : E BALAGURUSAMY.
- Erdem, H, "Design and implementation of data acquisition for fuzzy logic controller", Industrial Technology, (2002). IEEE ICIT ('02. 2002)IEEE International Conference Page(s):199- 204 vol.1. on(11-14Dec. 2002)
- "Energy Efficient Automized Public Utility Building" [http://www.ijarcsse.com/docs/papers/Volume\\_4/5\\_May2014/V4I5-0186.pdf](http://www.ijarcsse.com/docs/papers/Volume_4/5_May2014/V4I5-0186.pdf).
- Kadam Shah, PrakashSavaliya and Mitesh Patel "Automatic Room Light Controller With Bidirectional Visitor Counter" (IJICTRD) International Journal of ICT Research and Development | Vol-1 Issue-4 | ISSN: 2395-4841.
- GauravWaradhar, Hitesh Ramina, VinayMaitry, TejasviAnsurkar, AshaRawat and Parth Das, "Automatic Room Light Controller With Bidirectional Visitor Counter," International Journal of Engineering Science and Computing (IJESC), March 2016.
- <http://ww1.microchip.com/downloads/en/DeviceDoc/25093B.pdf>.