

# Using LoRa Technology to Monitor and Control Sensors in Greenhouse

Savitri Mhetre<sup>1</sup>, Deepak Kadam<sup>2</sup>

<sup>1</sup> Student, <sup>2</sup> Professor

Department of Electronics & Telecommunication Engineering

Dr. V.P.S.S. Ms Padmabhooshan Vasantraodada Patil Institute of Technology, Budhgaon,  
Sangli, Maharashtra 416304 India.

\*\*\*

**Abstract** - Due to the corona pandemic and its consequences from curfews and the difficulty to reach work centers, including the greenhouse in the agricultural sector. The idea to use LoRa, one of the latest wireless communication technologies, which has ability to connect and use IoT to ensure monitoring in any workspace. The designs consists of two section: The first is to a group of sensors and its measure and control inside the greenhouse and send data to the next section using LoRa technology and the second section is to monitor and control the readings data remotely, Using LoRa technology to receiving first section data, and connecting it to the internet or using IoT network to provide access and monitoring from anywhere in the world, The readings can have obtained after uploading it to the cloud computing, the data deal with website which allow monitoring the sensors wherever the internet service is available, the system also gives the ability to send feedback signal to greenhouse. The project provides integrated greenhouse control at a distance 2 to 15 km.

**Key Words:** LoRa, Internet of Things (IoT), Greenhouse, Monitor and Control.

## 1. INTRODUCTION

The idea of IoT technologies that had been in existence for decades. These technologies include electro-mechanical systems, the internet and wireless automation. The idea of using IoT to develop automation has become a thing to desired and have implemented. As with every technology, automation is in its developmental stages and as such requires a lot of researches and inputs from industries, academia and professionals alike. The Long-Range Wireless Area Network i.e., LoRa is the technology which is latest technology which is simple to use and highly efficient.

By using LoRa technology, the appliances, huge machineries, agricultural pumps, etc. it can be control and check status of the equipment using IoT and LoRa module. In this system, the status of the entire running system i.e., electrical parameters like voltage, current, power, etc., mechanical parameters, temperature, switching, etc. can be control wirelessly using LoRa. The LoRa Technology passes very large range i.e 0 KM to 50 KM without internet facility and can have wide network with the application of IoT. In this system, there are two transceivers, one is LoRa module

and another is IoT server which is situated anywhere in the system and using internet appliances can be monitor and control easily.

So, it is solution for the problems regarding to real time monitoring system for domestic, industrial and agricultural systems etc. thus the use of modern techniques in society must be equipped with sufficient usage of resources.

## 2. METHODOLOGY

IoT based appliance to monitoring and control system using LoRa technology is the Long-Range Wide Area Network (LoRaWAN) which transmit and receive data over large distance wirelessly with and less expenditure, less maintenance and more efficiency. For controlling the appliances Internet of Things is the best choice, but it has certain disadvantages which are overcome by using simply LoRa module. In this system, using transceiver LoRa modules it transmits and receive data and microcontroller take action on it and command send by user and switch on the relay system. Its long-range system which transmits data wirelessly which ranges upto 20km to 100km depends on bandwidth. Fig.-1.1 shows Block Diagram of To Monitor and Control Sensor Greenhouse Using LoRa Technology.

The controlling and monitoring sensors in the greenhouse including hardware components and software programs. The proposed system consists of two fields, one in the greenhouse and the other one is near the controller operator. Each one of those fields contains both hardware and software parts. In the greenhouse field, there are temperature and humidity, Soil moisture, and Rain detection, see Fig.1 These three sensors connected together or individually to Arduino microcontroller ATmega328P and it is connected to LoRa Module With low data rates, the LoRa allows the user to reach long ranges to send the data. It provides connectivity of the ultra-long-range spread spectrum and high sensitivity to interference while reducing current consumption.

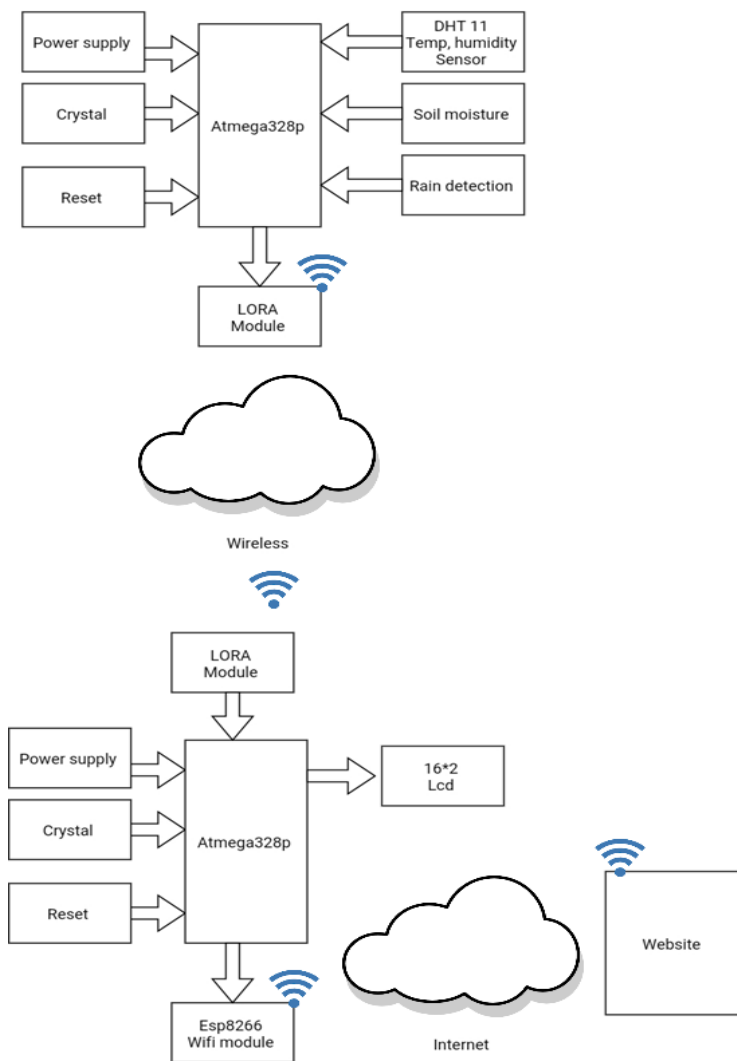

**Fig -1:** Block Diagram of To Monitor and Control Sensor Greenhouse Using LoRa Technology

Here we are using to microcontroller units One of the units is transmitter and second one is the receiver. first circuit transmit the data of various sensors such as dht11 temperature and humidity sensor, soil moisture sensor and rain detection sensor etc. from the first minute all the data is transmitted from circuit using Lora wireless module Transmitted data is received by another Lora module connected to the second unit Received data is displayed on 16/2 LCD display and connecting it to the Internet or using the (IoT) network to provide access and monitoring from anywhere in the world.

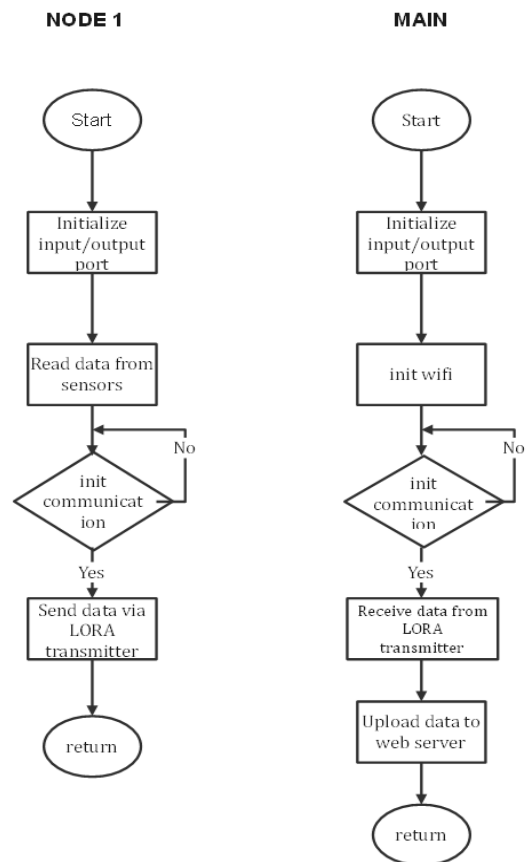

**Fig -2:** Flow Chart

### Hardware Description

#### ATMega328P

The ATMega328P is a single-chip microcontroller commonly it is used in Arduino products. It has a high performance and consumes low power, it has 6 Analog input pins, and its memory can go up to 32kb. Also, it has 2kb of SRAM and upto 1kb of EEPROM. Then, its clock speed stands at 16 MHz, and it has a total of 14 I/O pins. it operates at minimum temperature of 40 degrees centigrade and a maximum temperature of 105 degrees centigrade. it has two 8-bit and 16-bit timers. it's an advanced RISC with 6 Pulse Width Modulation (PWM) channels. it operates at a minimum voltage of 1.8 DC and a maximum of 5.5.

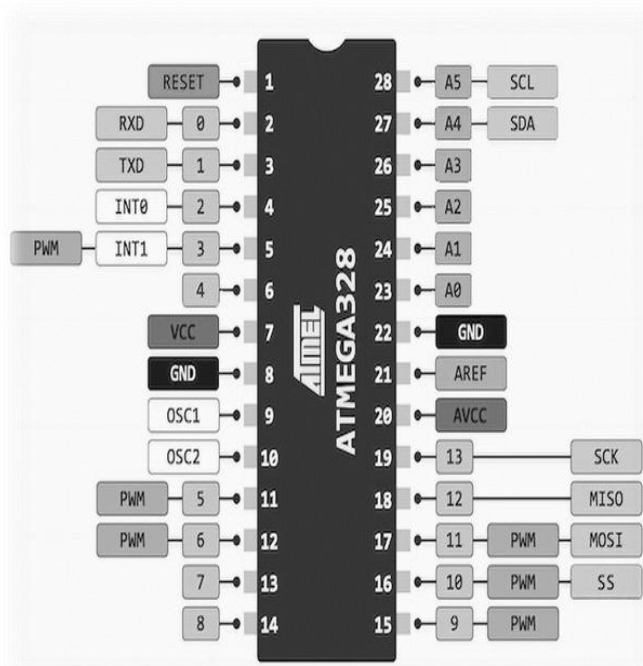

Fig-3: Pin Diagram of ATmega328P

### LoRa module

The LoRa is a wireless communication module developed based on Semtech's chips. LoRa (LoRa) is a less power wide area network (LPWAN) protocol developed by semtech. It is based on the spread spectrum modulation technique derived from the chirp spread spectrum (CSS) technology. LoRa module works of technology named LoRaWAN which is the communication protocols and system architecture for networks, the LoRa systems physical layer enables the long-range communication links. LoRa also controls the communication frequencies, data rate, and power for all devices.

### ESP8266 Wi-Fi module

ESP8266 Wi-Fi module is enabled system on chip (SoC) module. It is mostly used for the development of the Internet of Things embedded applications. The ESP8266 wi-fi module is a low-cost Wi-Fi microchip with full TCP/IP stack and microcontroller capability.

### DHT11 sensor and Humidity sensor

The DHT11 sensor is low-cost Temperature and Humidity sensor i.e ideal for hobbyists and prototyping applications. The DHT11 temperature sensor range: 0 – 50°C (±2°C) and DHT11 Humidity sensor range: 20-80% (±5%). Its Supply voltage: 3 to 5.5V. DHT11 sensor uses One Wire protocol. It integrates a thermistor and a capacitive Humidity sensor. An integrated ADC converter converts the

measured values into a digital signal, which is then output via the One Wire interface.

### Soil Moisture

A Soil Moisture sensor is one type of low-cost electronic sensor that is used to detect the moisture of the soil. This sensor can measure the volumetric content of the water inside the soil. This sensor is consisting of mainly two parts, one is Sensing Probs and another one is the Sensor Module. The probes allows the current to pass through the soil and then it gets the resistance value according to moisture value in soil. The Sensor Module reads the data from the sensor probes and processes the data and converts it into a digital/analog output. So, the soil moisture Sensors can provide both types of output Digital output (DO) and Analog output (AO).

### Rain Detection

The sensor that is used to notice the water drops or rainfall is called as a rain sensor. This type of sensor works like a switch. This sensor includes two parts like sensing pad and the sensor module. Whenever rain falls on the surface of the sensing pad then the sensor module reads the data from the sensor pad and to process and convert it into an analog/digital output. So, the output generated by this sensor is analog (AO) and digital (DO).

### 16X2 LCD Display

The LCD Display will be used to visualize the data locally it will help to operate the device standalone. The LCD screen is an electronic display module and find the wide range of application. A 16x2 LCD display is a very basic module and is a very commonly used in various devices and circuits. A 16x2 LCD means it can display the 16 characters per line and there 2 such lines.

## 3. CONCLUSIONS

This paper presented a scalable system to monitor and control greenhouse sensors, DHT11 temperature, humidity, soil moisture sensors and rain detection, which represent an important factor in the greenhouse environment. This system uses LoRa technology network that has high potential in future projects because many cities around the world plan to have the LoRa coverage as a necessary backbone of communication. The designed backend system can be easily integrated with the other Internet of Things (IoT) applications, so, can the system contributes not only as a greenhouse's monitoring and controlling system but also as an initial step for the future smart city development.

## REFERENCES

- [1] Yuanyi Liu, Maoli Wang, "Wireless Greenhouse Environment Monitoring System Based on LoRa Network", (2019) Journal of Food Science & Technology (ISSN: 2472-6419)
- [2] Thair A. Salih and Mohammed S. Noori 2020 IOP Conf. Ser.: Mater. Sci. Eng. 928 032058, "Using LoRa Technology to Monitor and Control Sensors in the Greenhouse", 2nd International Scientific Conference of Al-Ayen University (ISCAU-2020)\_DOI: 10.1088/1757-899X/928/3/032058
- [3] Mr. Anukesh A. Ambatkar, Mr. Vinod B. Ambatkar, Ms. Shreya G. Zade, Ms. Prachi J. Bhagat, Ms. Komal A. Korde, Prof. Kirti B. Nagne, "IoT Based Appliances Control and Monitoring System Using LoRaWAN Technology", International Research Journal of Engineering and Technology (IRJET) e-ISSN: 2395-0056 Volume: 07 Issue: 12 | Dec 2020 [www.irjet.net](http://www.irjet.net) p-ISSN: 2395-0072
- [4] M Chw Al Fajar, Octarina Nur Samijayani, "Realtime Greenhouse Environment Monitoring Based on LoRaWAN Protocol using Grafana", 2021 International Symposium on Electronics and Smart Devices (ISESD) 29-30 June 2021 IEEE
- [5] Van Anh Vu, Dong Cong Trinh, Tuan Christian TRUVANT, Thanh Dang Bui, "Design of Automatic Irrigation System for Greenhouse Based on LoRa Technology", 2018 International Conference on Advanced Technologies for Communications (ATC) DOI: 10.1109/ATC.2018.8587487
- [6] Shamali K. Makode, Radhika R. Harne, "Smart Agriculture Solution using LoRa and IoT", International Research Journal of Engineering and Technology (IRJET) e-ISSN: 2395- 0056 Volume: 06 Issue: 07 | July 2019 [www.irjet.net](http://www.irjet.net) p-ISSN: 2395-0
- [7] Jessin Mathew, Riya Rajan, Rangit Varghese, "IoT Based Street Light Monitoring & Control with LoRa/LoRaWAN Network", International Research Journal of Engineering and Technology (IRJET) e-ISSN: 2395-0056 Volume: 06 Issue: 11 | Nov 2019 [www.irjet.net](http://www.irjet.net) p-ISSN: 2395
- [8] Shreya B B1, Yamini Niharika P2, Thota Vedaasree3, Yashaswini U S4, Dr. Roopa G M 5, Prof. Vaishnavi Ajay Inamdar, "LoRa Based Framework for Smart Greenhouse Monitoring Systems", International Journal for Research in Applied Science & Engineering Technology (IJRASET) ISSN: 2321-9653; IC Value: 45.98; SJ Impact Factor: 7.538 Volume 10 Issue VI June 2022- Available at [www.ijraset.com](http://www.ijraset.com)