

Embedded system-based intelligent wheelchairs for disabled people

Sanket Sujay Shinde¹, Gurudas Ramdas Mali²

¹Sanket Sujay Shinde, MCA, YTC Satara

²Gurudas Ramdas Mali, MCA, YTC Satara

³ Asst.prof.V.V.Kadam, Asst.prof.S.S.Jadhav, Dept. of MCA, Yashoda Technical Campus Satara, Maharashtra, India

Abstract - Mobility impairment is a major problem affecting the independence of people with physical disabilities. Therefore, mobility aids need to be improved in order to improve people's living standards. This paper describes the design of smart wheelchairs using embedded systems. This paper describes the design and development of smart wheelchairs using embedded systems. The proposed design of the wheelchair can be controlled via Bluetooth, thus allowing the user to control the wheelchair with less effort. In addition to the virtual joystick control interface, touch commands are provided to the system to enhance user interaction. It helps people with disabilities to carry out their daily indoor activities independently. Experiments will be conducted to verify the functions of the developed smart wheelchair.

1. INTRODUCTION

This paper focuses on the problem of disabled people who want to commute by themselves but cannot drive for natural reasons. This proposed project focuses on Bluetooth control of a wheelchair with automatic movement in directions such as forward, backward, left, right, and diagonal by Bluetooth commands. This model uses an Android app to pass Bluetooth commands to the Raspberry PI 3 via Bluetooth communication with the Bluetooth module. People who become disabled face many problems when moving from one place to another. Most disabled people use conventional wheelchairs. Previously, wheelchairs were manually operated. Operated by hand or by another person if the patient is unable to drive. For this type of wheelchair, the person must have sufficient strength to control it. Otherwise, another person must be present to monitor the movement of the chair. Some face big problems. In this case, a second person is always required [1]. So people working small parts of the body can use it with minimum effort and maximum precision and speed control. The device is loaded with many extra features that make it smart. This wheelchair is therefore designed to overcome the above problems and allow the end-user to perform only safe movements and perform daily necessities.

This paper describes a simple, intelligent, affordable, motor-controlled key device that is easy to use, provides customized commands to the, and allows the wheelchair to move independently. I'm here. A smart phone is used as the robot's brain to give instructions. Bluetooth simplifies his

communication from wired to wireless. The IR sensor is also used to detect and notify you when you find an obstacle in your passageway. This design requires the user to control the movement of her wheelchair using Bluetooth commands. These commands are received by the Android application on the user's phone, which is connected to the wheelchair via the Bluetooth module. Commands issued relate to the and RS channels and are received by the module. The purpose of the Bluetooth controlled wheelchair is to listen to the and respond to commands received from the user. This application is just an artificial intelligence application. Here, the system requires training of the user, after which the device will start capturing his commands issued. This is done by attaching comment to the controller via code.

2. Working Methodology

The Smart Wheelchair consists of a wheelchair-controlled Bluetooth module. To set up a system for cheap monitoring, the Raspberry PI 3 UNO allows you to approach the system without viewing the unit. Wheelchair movement can be controlled manually via Bluetooth. Commands are implemented using a Bluetooth mobile app and sent to the Raspberry PI 3 UNO where the commands are processed. [3,4] After processing, the commands are sent in the form of digital signals to the motor driver IC to control it. wheelchair movement. This system was also developed to control wheelchairs with Android devices. The user can steer the wheelchair by selecting specific directions displayed in the four quadrants of the Android smartphone screen. Raspberry PI 3 UNO will try to execute every command. Motor drivers and Bluetooth modules work with this system. This is how you have a car chair that you can drive with your Android device. This project uses a Bluetooth module, namely HC-05. When a button is pressed in the Bluetooth app, the Bluetooth module recognizes the corresponding button pressed in Bluetooth. Your Android smartphone app runs on a smartphone and uses drawing commands recognized by the smartphone's Bluetooth. The command is processed and each transliteration key pressed is executed inside the Bluetooth module and sent through the Bluetooth app to the receiver which is a Raspberry PI 3. This project is controlled by a Raspberry PI 3. The Raspberry PI 3 used is the Raspberry PI 3 UNO. The Raspberry PI 3 UNO is a root development board for the ATmega328 microcontroller with 6 analog

input means and 14 digital I/O pins. It has 32 KB of flash memory (ISP), 2 KB of RAM, and 1 KB of EPROM. This board offers the possibility of serial communication via UART, SPI. It can operate at a clock frequency of 16MHz. In this project, 2, 3, 4, and 65 are digital input/output pins configured as output pins by the Raspberry Pi 3. Serial communication uses 0's and 1's on the HC 05 module. Text received via Bluetooth is sent to the Raspberry Pi 3 Uno board using the UART serial communication protocol. The Raspberry Pi 3 UNO program controller checks if the received letters match the order of the letters and does not control the movement of the wheelchair at the start.

Table 1. Bluetooth-Controlled Wheelchair Directions

Character	Direction	Function
N	North	Moves Forward
E	East	Moves Right
W	West	Moves Left
S	South	Moves Backward
0	Stop	Motor Stops
1	North-West	Moves Forward Left
3	North-East	Moves Forward Right
7	South-west	Moves Backward Left
9	South-East	Moves Backward Left

through android device, then this is transferred to the Raspberry Pi using bluetooth module which is the transmission unit to the receiving unit. According to the desired character opted by the user, the Raspberry Pi gives the signal to the Motor driver as per the algorithm used in the software program. Motor driver gets signal using serial communication and moves the wheelchair either forward, backward or stop. The Android application is connected to the Bluetooth module HC-05 and is installed on the wheelchair by Bluetooth. The commands are sent to the wheelchair using Bluetooth commands present on the Android application. The transmitter of the Bluetooth can take Bluetooth commands which are converted to encoded digital data for the advantage of the adequate 100 meters range from the wheelchair. The receiver part will decode the data via motor driver IC for the necessary commands.

3. Results and Discussions

The Raspberry Pi 3 program checks the code received by the Bluetooth module and if it is a matching character with a given program, then with each respective character the Raspberry Pi 3 sends a signal to the motor driver. Depending on the received character the Motor. This Bluetooth-module is simple to interface the wireless connection devices. Now the main crucial component of the wheelchair is the L293D Motor Driver. It is a dual H Bridge high current motor driver IC. This is used because digital pins of Raspberry Pi 3 can't source enough current to run the motor of a wheelchair.[5] H-bridges are useful in controlling the direction of rotation of the motor enable pins of the IC being actively high are connected to the 5

volts. 4 output pins of L293d IC are connected to Motors A and B at the receiver end.

3.1 Simulation Results

Used Software and application: Proteus 8 Professional Simulation Software, Bluetooth Joystick App

Fig. 3. Motors moves in forward direction as the joystick is in forward direction

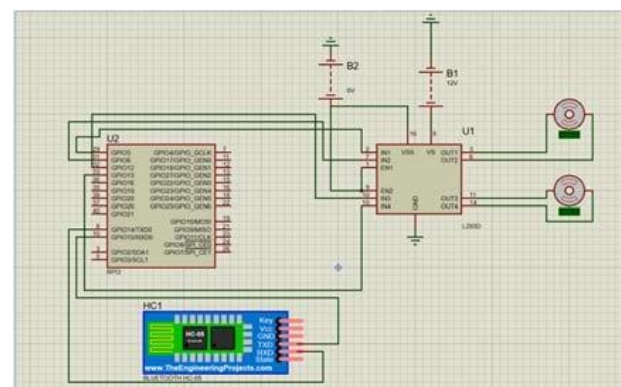

Fig. 1. Block Diagram of Bluetooth controlled Wheelchair

The power supply of this entire system is given through a battery. This system's hardware consists of an embedded system based on the Raspberry Pi 3b, Bluetooth module (HC-05), Motor driver (L298N), Android device and dc motors. Bluetooth Module is the communication medium between the user interface through the android device and the system by means of character commands given to the android device.

All the software application program is installed in the Raspberry Pi and android device. When the user opts for the desired character command through the bluetooth app

Table 2. Rotation of motors with inputs

Inputs	Rotation of motors with inputs according to user commands
Input 1 = HIGH	Motor 1 rotates in clockwise direction
Input 2 = LOW	
Input 3 = HIGH	Motor 2 rotates in clockwise direction
Input 4 = LOW	
Input 1 = LOW	Motor 1 rotates in anti-clockwise direction
Input 2 = HIGH	
Input 3 = LOW	Motor 2 rotates in anti-clockwise direction
Input 4 = HIGH	
Input 1 = HIGH	Motor 1 stays still
Input 2 = HIGH	
Input 3 = HIGH	Motor 2 stays still
Input 4 = HIGH	

The wheelchair moves forward when it is instructed to do so by the movement of both the wheels in clockwise direction. It moves backward when both the wheels are given input to move in an anti-clockwise direction. It turns right when the left wheel only turns clockwise and moves left when the right wheel turns clockwise. It moves diagonally forward to the right when the left wheel initially turns clockwise and after a delay, the right wheel also starts turning clockwise. It moves diagonally forward to the left when the right wheel initially turns clockwise and after a delay, the left wheel also starts turning clockwise. It moves diagonally backward to the right when the left wheel initially turns anticlockwise followed by the right wheel after a delay. It moves diagonally backward to the left when the right wheel initially turns anticlockwise followed by the left wheel after a delay.

4. Conclusion

The Present Bluetooth-controlled wheelchair gives a safety and staunch system. It provides a comfortably getatable and different varieties of functions. In this, we developed a wheelchair that includes ultrasonic sensors to smart track the paths and can detect the objects in the middle of the path along with an ability of maintaining good care to refrain from tragedy, good results are obtained. Hence, parietic peoples can be reliable-self, safely, and ease controlling with this wheelchair. Future changes can improve the wheelchair more. The presented wheelchair will be done by appending new advanced sensors, in order to make the wheelchair increased friendliness and to refrain from tragedy by learning-self. Security will be integrated for retrieval with the assistance.

REFERENCES

1. Asakawa T., Nishihara K., Yoshidome T.: IEEE International Conference on Robotics and Biomimetics, pp. 1260-1265, China (2007).
2. Krishnamoorthy A, International Journal of Reconfigurable and Embedded Systems (IJRES), Vol. 6, No., pp. 82~87 ISSN: 2089- 4864, DOI: 10.11591/ijres.v6.i2.pp82-87. (2, July 2017).
3. Deepak Kumar Lodhi et al, International Journal of Computer Science and Mobile Computing, Vol. 5 Issue.5, May- 2016, pg. 433-438 ©, IJCSMC.(2016).
4. Simpson RC, LoPresti EF, Hayashi S, Guo S, Ding D, Cooper RA. Technology and Disability: Research, Design, Practice and Policy: 26th International Annual Conference on Assistive Technology for People with Disabilities (RESNA) [CD-ROM]; 2003 Jun 19–23; Atlanta, GA. Arlington (VA): RESNA Press;(2003).
5. Shaiju Paul, Ashlin Antony, Aswathy B., International Journal of Computing and Technology (IJCAT). Volume 1, (1, February 2014).