

IOT-BASED HAZARDOUS GAS LEAKAGE DETECTION

Siranthini Balraj¹, Ruchika Chakraborty^{1*}, Ayan Prakash Gogoi Boro², Bapon Sarkar³

¹Assistant Professor, Department of Electrical and Electronics Engineering, SRM Institute of Science and Technology, Ramapuram, Chennai, India

^{1*}Student, Department of Electrical and Electronics Engineering, SRM Institute of Science and Technology, Ramapuram, Chennai, India

²Student, Department of Electrical and Electronics Engineering, SRM Institute of Science and Technology, Ramapuram, Chennai, India

³Student, Department of Electrical and Electronics Engineering, SRM Institute of Science and Technology, Ramapuram, Chennai, India

Abstract - Human beings and all the living organisms in this world needs fresh and healthy air to survive. In recent years, with the increase in gas consumption, gas leakage has become a problem. Leaked gas causes gas waste, especially because of its combustible property, it can harm living organisms and various industries. All components are controlled by an Arduino which acts as the central processing unit of the setup. When the sensor detects a leak of the many combustible gases, it sounds an alarm with a buzzer. This alarm supports a small LCD that displays the amount of the gas leak and alerts personnel to turn on the exhaust fan or stop the incoming gas at a particular section. This will notify to take immediate security measures. The capabilities of this gas detection system are not only to monitor the various surroundings but also help to prevent the gas leak and hence minimize the chances of fire and leakage damages.

Keywords- Gas detection, Arduino, Buzzer, LCD, Alert, etc

1. INTRODUCTION

The Internet of Things strives to make life easier and faster by automating all the small tasks involved in human life. Today technological advances like IOT are making everything smart. Since IoT is very beneficial in automating tasks, the advantage of IoT can also help improve convenient security methods.

Security performs a significant role at the same time as constructing homes, buildings, and industries in addition to towns. The enlarged focus of certain gases within the surroundings are maybe exceptionally unsafe. Nowadays, everyone wishes for a facility that reduces effort and time as well as expects their work to be as easy as possible. The prime aim of the paper is to alert people with the help of a buzzer and detect the hazardous gases present in the air. This is done using an MQ5 sensor. The MQ5 sensor is used to detect gas leakages for various applications. The MQ5

sensor detects the concentration levels of the gases and outputs an analog value which can be later converted into a digital signal. As soon as the gas is detected by the MQ5 sensor it displays alert messages on the LCD screen. The user will get alerted via messages on the LCD screen. This is an efficient way to automatically detect and control gas leaks. It also prevents accidents. The idea of gas detection and control can be implemented on a large scale in various industries. The system can be installed in kitchens, hostel cafeterias, etc. This helps reduce accidents caused by gas leaks in homes and commercial facilities. This system is low cost, so it is affordable, prevents many accidents, saves many accidents, saves many properties and lives. The MQ5 sensor is used to detect H₂ (molecular hydrogen), LPG, CH₄ (methane), CO (carbon monoxide), and alcohol. This system is not only capable of detecting a gas leakage as well as alerting the user of the gas leakage through a buzzer alarm.

2. LITERATURE SURVEY

Belkacem Khadi et al [1] has proposed in an endeavor on the concept of multi-robot intellect referred to as SR(swarm robotics), inspired by the nature and observing groups such as groups of ants, flock of birds, schools of fish and groups of bees. In SR, if a group of robots performs a task in an intellectual approach then they are referred to as SI (swarm intelligence), it is a passive networking system in which every distinct bot of the group interacts with one another and with the outside ambiance. The field deals with the design of a large number of simple robots, their physical properties, and their controlling behavior. There are various simulation platforms that are used to test the structure and algorithm of swarm robots. R. Imtiaz, et al [2] has proposed a work on implementing two different kinds of robots, which included an explorer robot and a carrier robot. In this configuration there are four robots, one master robot or explorer robot which works as the leader and three slave robots or carrier robots. The explorer robot travels the entire path set towards target and gives the instruction

about the path to the carrier robots. Carrier robots follow the path according to master robots command. Thus, any work can be completed in less time and much efficiently. Zigbee module is used as the communication device for the intercommunication between robots, and is used in each robots.

Mohd. Daneel Khan, et al [3] has proposed work on the application of S-bots in disaster management. Swarm intelligence provides a collective work to perform a certain task which is much accurate and efficient. During earthquakes when large number of buildings fall down and lots of people are trapped under the building swarm it is impossible by humans to reach that places and rescue people. In this situation swarm of learning, birds can be used to provide the information about the areas and give data to make accurate decisions. It is also used for locating a safe location and to give the exact path of the location. Abhishek, P. Bharath, et al [4] gas leakage can be detected by using the gas sensor, when a small amount of gas is brought near the sensor it starts alerting the user about the leakage of the gas using iot. P. M. Vidya, S. Abinaya, G. G. Rajeswari, and N. Guna, et al [5] has suggested that the leakage of the gas can be detected by using various gas sensors

Kavitha B et al [6] has designed an alarming system for the industry based on the huge amount of leak of gas from the container. Kalpesh Gupta et al [7] has designed an automatic window opening system when the gas is leaked at a certain amount of volume continuously.

3. SYSTEM OVERVIEW

Hardware Requirements

Arduino Uno

The Arduino UNO is an open-source microcontroller board based on Microchip's ATmega328P microcontroller and developed by Arduino. cc. its main aim is to make electronics to be as easy as possible. It uses different microcontrollers, containing several input and output pins. It provides an integrated development environment (IDE). Arduino contains several numbers of parts and integrated interfaces in a particular circuit board.



Figure.1

Relay

A relay is an electrical switch that is used to control all other electronic devices by using the electromagnetic mechanical toggle



Figure.2

LCD display

The LCD is used to display the message "Gas in Zone Detected" on the first coded display in the program to indicate hazards. All messages, data, and commands displayed on the LCD are LCD registers. its operating power supply ranges from +5.0 V or +3.0 V.



Figure.3

ESP8266 WIFI Module

ESP8266 is a low-cost WIFI microchip with a complete TCP/IP stack and microcontroller functionality from EspressifSystems.

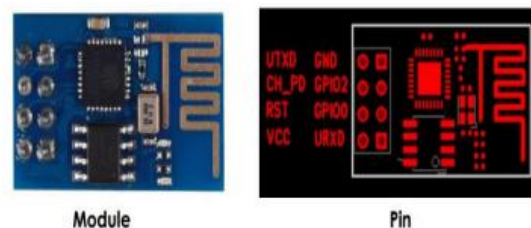

Figure.4

MQ-5 Sensor

The Grove Gas Sensor Module (MQ5) is useful for gas leak detection (home and industrial). Suitable for the detection of H2, LPG, CH4, CO and alcohol. High sensitivity and fast response time allows the measurements to be

made quickly as possible. The sensitivity of the sensor can be adjusted with a potentiometer.



Figure.5

Buzzer

A buzzer or buzzer is a mechanical, electromechanical or piezoelectric (piezo for short) audible signalling device. Common uses of buzzers and beeps include alarm devices, timers, and user acknowledgment of user input such as mouse clicks and keys.



Figure.6

Software Requirements

- A) Arduino IDE
- B) Language C++

4. SYSTEM OPERATION

In this proposed system, the gas leakage is detected by MQ 5 sensor which is interfaced by Arduino uno, when the gas leakage is detected through the MQ 5 sensor the lights gets off with buzzer alarm and display alert message in LCD display. Further, working of this proposed system is as below

This gas sensor is used to detect hazardous gases in industry. This sensor can detect the following gases:

- Carbon Monoxide CO 1 - 1000ppm,
- Ethanol C₂H₆OH 10 - 500ppm,
- Hydrogen H₂ 1 - 1000ppm,
- Ammonia NH₃ 1 - 500ppm,
- Methane CH₄ >1000ppm

When detected, it will automatically turn on. The detected values are sent as inputs to the main component, and the

buzzer will make a sound. Users can view sensor status and take necessary actions accordingly.

Figure 7 depicts the architectural block diagram of the proposed gas leakage detection system

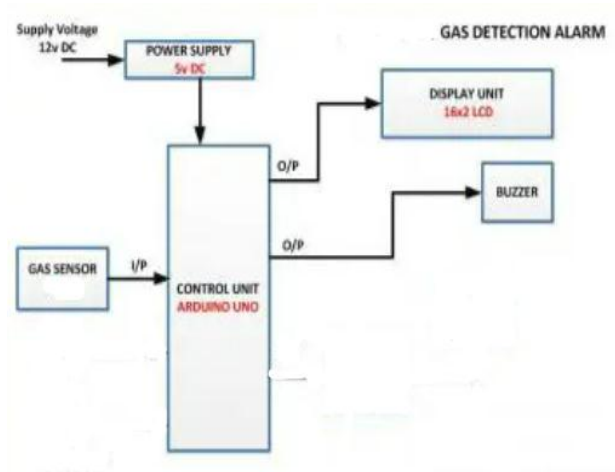

Figure 7. Architecture of gas leakage detection system.

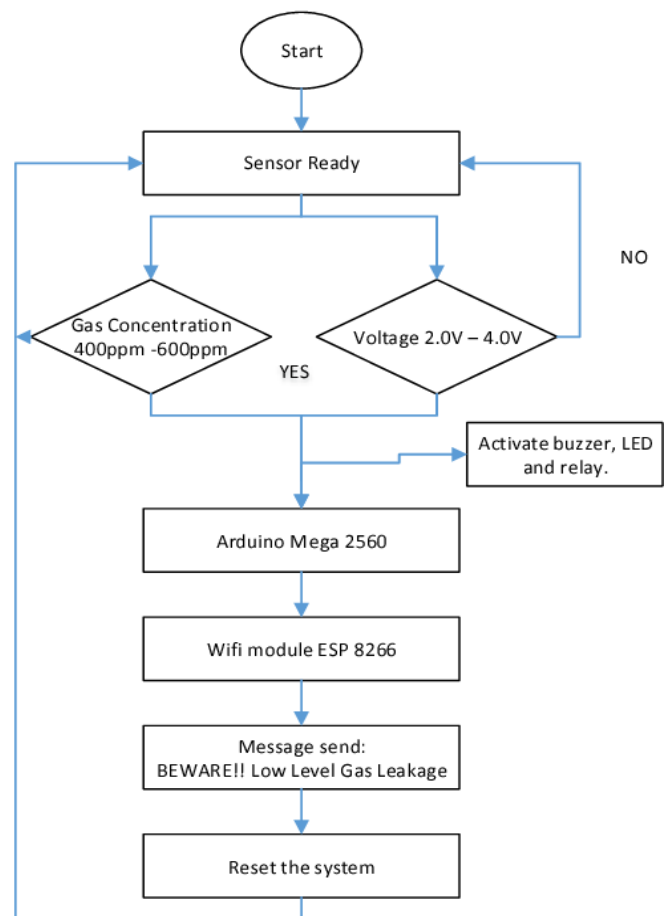

Figure 8. Flow diagram of the activities of the gas leakage detection system

5. EXPERIMENTAL RESULTS

The prototype of the project system is shown in Figures 9 and 10. This proposed system is developed to detect and monitor gas leakage. when a small amount of gas is brought near the MQ5 sensor, it displays the message in LCD i.e “GAS LEAKAGE DETECTED” and the gas value is also shown at the time of the detection of the leakage of the gas and the system monitors the LPG level and displays the message with the gas value. The developed system will be helpful to the customer. It helps them to upgrade their safety norms and aids to prevent the major disaster. It also helps in protecting life and property from apparent accidents. The primary aim of this proposed system is therefore to detect the gas leakage which is detected though gas sensor and user should be notified to prevent injure or outburst via buzzer and alert the user.

It helps them to upgrade their safety norms and aids to prevent the major disaster. It also helps in protecting life and property from apparent accidents. The primary aim of this proposed system is therefore to detect the gas leakage which is detected though gas sensor and user should be notified to prevent injure or outburst via buzzer and alert the user.



Figure.9 Prototype model of the gas leakage detection system

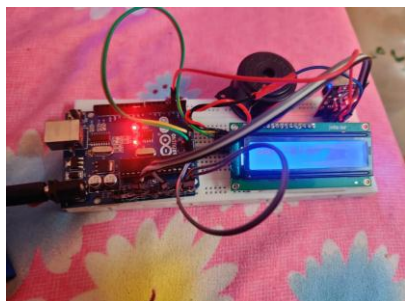
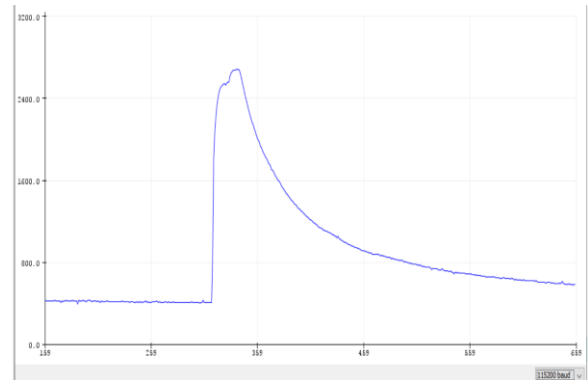

Figure.10 Gas value is detected by the sensor and the buzzer is switched on

Analog value of the gas sensor



When small amount of gas is brought closer to the MQ5 sensor, the analog value spikes above 1000.

6. CONCLUSION

This paper aims to ensure the monitoring and detection of hazardous gases to meet safety standards. The system detects gas in the atmosphere and continuously updates and displays the gas values which can be easily viewed by the user via a LCD screen. The system is quite responsive and can stop crisis situations more quickly than manual methods. The system alerts and responds to leakage by alerting the user. In the future, this system will be packed with advanced features to provide users with greater security and relaxation. The popularity of handheld devices has advanced the field of smart gas sensors, greatly expanding the range. The need to ensure workplace safety is expected to be the main driver of the market in the upcoming years.

REFERENCES

- [1] Belkacem Khaldi, Foudil Cherif, “An Overview of Swarm Robotics , Swarm Intelligence Applied to Multi-robotics,” International Journal of Computer Applications (0975 – 8887) Vol 126 – No.2, September 2015, India.
- [2] R. Imtiaz, B. Ashokkumar, M. Danny Frazer “Implementation Of Load Sharing Using Swarm Robotics,” International Research Journal of Engineering and Technology, Volume: 03 Issue: 03, (pages: 1855 – 1862) | March-2016 , India.
- [3] Mohd. Daneel Khan, Krantee Jamdaade; “Application of Swarm Intelligence in Disaster Management”, International Journal on Future Revolution in Computer Science & Communication Engineering Volume: 4 Issue: 6 | pp 77-84 June - 2018 , India

[4] Abhishek, P. Bharath "Automation of lpg cylinder booking and leakage monitoring system-IJCRD"

[5]P. M. Vidya, S. Abinaya, G. G. Rajeswari, and N. Guna "Automatic lpg leakage detection and hazard prevention for homeseurity-National Conference on VLSI, Embedded and Communication & Networks"

[6] Kavitha B C,VallikannuR "IOT Based Intelligent Industry MonitoringSystem –SPIN 2019"

[7] Kalpesh Gupta, Gokul Krishna G and Anjali T "An IoT Based System for Domestic AirQuality Monitoring and Cooking Gas Leak Detection for A Safer Home-International Conference on Communication and Signal Processing, 2020"