

Switched Inductor Based Buck-Boost Transformerless Inverter

Anna Sunny¹, Dr. Reenu George²

¹PG Scholar, Department of EEE, MACE, Kothamangalam, kerala, India

²Professor, Department of EEE, MACE, Kothamangalam, kerala, India

Abstract - Currently, single phase transformerless grid-connected photovoltaic inverters are undergoing further developments, with new designs, and interest of the solar market. In comparison to the transformer galvanic isolation-based inverters, its advantageous features are lower cost, lighter weight, smaller volume, higher efficiency, and less complexity. Galvanic connection of the grid/load and the dc sources in transformer less systems can introduce additional leakage currents because of the earth parasitic capacitance. In order to reduce the leakage current and to improve the gain a switched inductor based buck-boost transformer less inverter (BBTI) topology is presented. This topology has the buck-boost ability which enables step up and step down operation of input voltage and has low leakage current due to common terminal is shared between grid/load and input. Another feature of the

topology is that it uses switched inductor concept which provides high conversion gain ratio. Symmetric operation of inverter during both half cycles is obtained, which enables negligible DC current injection. In addition, two out of five switches of the topology operate at a line frequency, thereby, it exhibits low switching losses. A simple strategy is implemented to control the inverter topology. Inverter is analysed at all operating modes and simulated using MATLAB R2017b. Hardware is implemented using dSPACE DS1104 controller.

Key Words: Transformerless, Buck-Boost, Inverter, MATLAB, dSPACE

1. INTRODUCTION

Photovoltaic power supplied to the utility grid is gaining more and more attention. Numerous inverter circuits and control schemes can be used for photovoltaic (PV) power conditioning system (PCS). Generally, the PV fed transformerless inverters suffer from leakage currents. To overcome the leakage currents, the researchers have come up with numerous PV fed transformerless inverter topologies and control strategies. For example, grid-connected central or string inverter configurations consist of strings of PV panels which does not require boost stage. However, the low voltage PV source requires a boost stage which reduces the efficiency of the system. Several researches have come up with the buck derived transformerless inverters which may not work during the low voltage PV source or PV source with shaded conditions. It is advisable to have transformerless inverter topologies with the buck-boost capability to have a wide operational range of PV sources. In this context, it can be understood that

nowadays researchers have been showing more interest in proposing buck-boost based transformerless topologies.

To overcome disadvantages of grid connected inverters, a buck-boost transformerless inverter topology is introduced with only five power switches [1]. The major advantages of the this topology are zero leakage current due to the common terminal shared between PV and grid neutral, negligible DC current injection due to the symmetry of operation in both positive and negative half-cycles, lesser number of controllable switches which makes the system more reliable and highly efficient, and wide range of PV power tracking due to the presence of buck-boost operation. To improve gain, switched inductor concept is employed in buck boost inverter [5].

2. CIRCUIT TOPOLOGY

Inverter used for DC to AC conversion, can be of buck inverter, boost inverter, and buck boost inverter. The buck boost inverter can be derived from the normal buck boost DC-DC converter and full bridge inverter. Gain of the buck boost inverter can be improved by introducing a switched inductor concept to the input inductor. A switched inductor based buck boost inverter has four working modes. Circuit diagram is shown in figure 1. Circuit consists of five power switches S_1, S_2, S_3, S_4 and S_5 , four diodes, three inductors, one capacitor C, and a resistive load R.

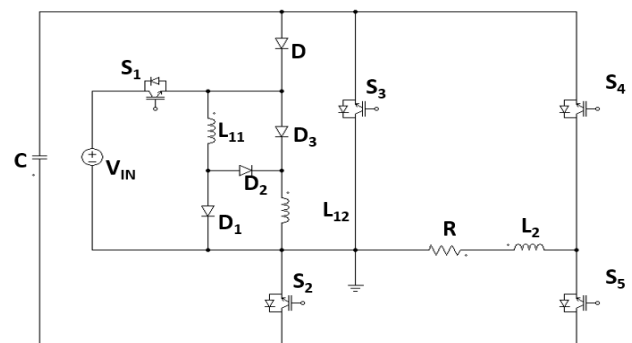

Fig -1: Switched inductor based buck boost inverter

2. MODES OF OPERATION

The continuous conduction mode (CCM) of the buck boost inverter is mainly divided into four modes. The mode 1 and mode 2 correspond to the positive half cycle and mode 3 and mode 4 correspond to the negative half cycles of the output voltage.

2.1 Mode 1

In this mode, the switches S_1 , S_3 , and S_5 are turned ON. The energy storage inductors L_{11} and L_{12} stores energy from source through power switch S_1 and capacitor C supplies energy to the load through switches S_3 and S_5 . All the current flowing paths corresponding to this mode of operation are highlighted with thick lines as shown in figure 2.

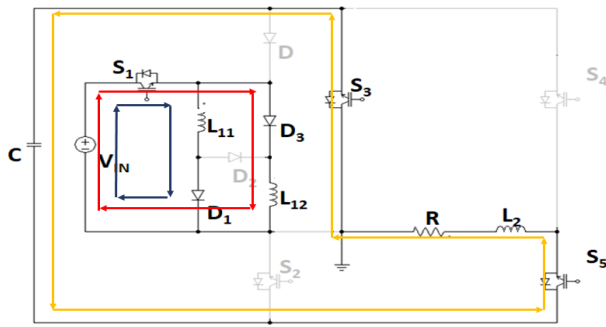

Fig -2: Operating circuit of mode 1

2.2 Mode 2

In this mode of operation, the power switch S_5 is turned ON and all the remaining switches are turned OFF. The inductors L_{11} and L_{12} supply its stored energy to the capacitor C . The current in the inductor L_2 freewheels through switch S_5 and antiparallel diode of switch S_2 . All the conducting paths correspond to this mode of operation are highlighted with thick lines as shown in figure 3.

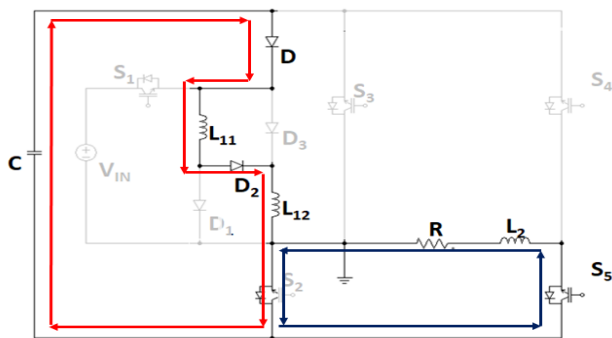

Fig -3: Operating circuit of mode 2

2.3 Mode 3

During this mode, the power switches S_1 , S_2 , and S_4 are turned ON. The capacitor C supplies energy to the load through power switches S_2 and S_4 . The energy storage inductors L_{11} and L_{12} store energy from the input source through switch S_1 . All the conducting paths corresponding to this mode of operation shown are in figure 4.

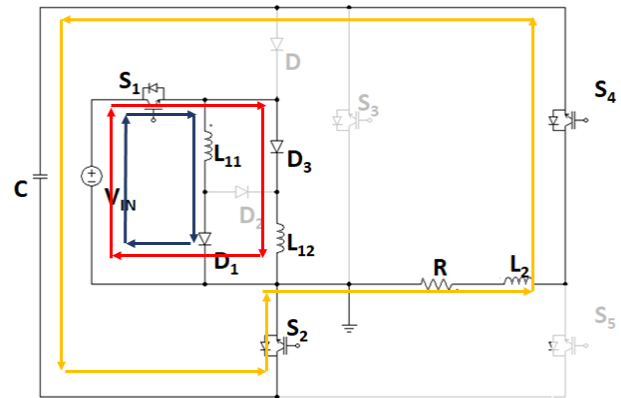

Fig -4: Operating circuit of mode 3

2.4 Mode 1

During this mode, the power switch S_2 is kept ON while the remaining power switches are turned OFF. In this mode, the inductors L_{11} and L_{12} supply its stored energy to the capacitor C . The current in the inductor L_2 freewheels through switch S_2 and antiparallel diode of switch S_5 . All the conducting paths corresponding to this mode of operation are highlighted with thick lines as shown in figure 5.

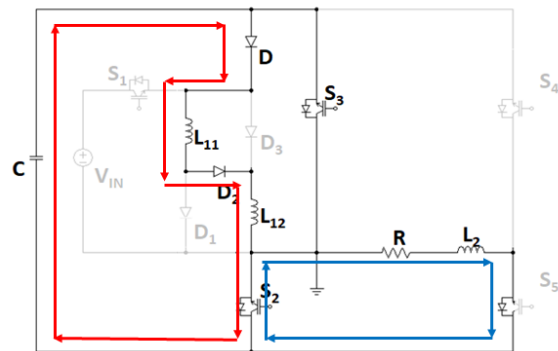

Fig -5: Operating circuit of mode 4

2. DESIGN CONSIDERATIONS

The input voltage V_{IN} is taken as 75V. The components are designed for an output voltage V_O of 110V. The pulses are switched at the rate of 10kHz.

$$G = \frac{d^2}{1-d} \tag{1}$$

d = modulation index

$$L_{11} = L_{12} > \frac{(d \cdot V_{IN})^2}{2 \cdot P_O \cdot f_s} \tag{2}$$

Voltage ripple ratio of capacitor C is less than 5% of V_c

$$V_C = \frac{d}{1-d} \tag{3}$$

$$C > \frac{P_O}{\Delta V_C * V_C * f_s} \tag{4}$$

2. SIMULATION AND RESULTS

Simulation parameters for the switched inductor based buck boost inverter is given in Table 1. The switches are IGBT/Diode with constant switching frequency of 10kHz.

Table -1: Simulation parameters

Parameters	Specification
Input voltage (V_{IN})	28V
Output voltage(V_O)	110V
Switching frequency(f_s)	10kHz
Rated output power(P_O)	300W
Output load resistance(R_O)	40Ω
Inductor L_{11} & L_{12}	70μH
Capacitor C	50μF

The switched inductor based buck boost transformerless inverter is simulated in MATLAB/SIMULINK by choosing the parameters listed in Table 1. Gate pulse generation circuit is shown in figure 6.

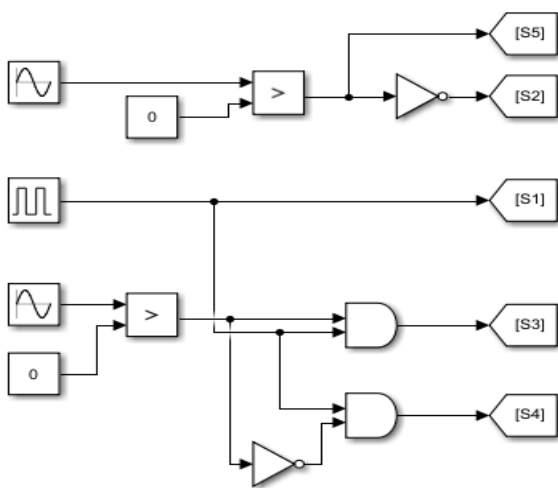

Fig -6: Gate pulse generation circuit

The simulation results of the switched inductor based buck boost inverter is shown in the following figures.

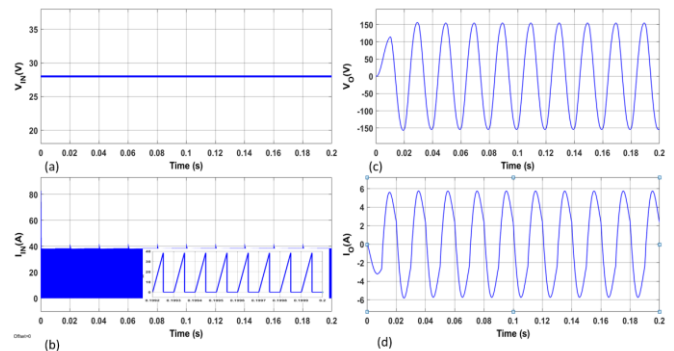

Fig -7: (a) Input voltage V_{IN} , (b) Input current I_{IN} , (c) Output voltage V_O and (d) Output current I_O

Figure 7 shows input and output voltage and current. Input voltage V_{IN} is 28V and the input current I_{IN} is 19A. Output voltage V_O is 110V and the output current I_O is 4.1A.

Figure 8 shows gate pulse and voltage across switches S_1 , S_2 and S_3 . The switching frequency is chosen to be 10kHz. Voltage across switch S_1 is 225V, voltage across switch S_2 is 190V and voltage across switch S_3 is 190V.

Figure 9 shows gate pulse and voltage across switches S_4 and S_5 . The switching frequency is chosen to be 10kHz. Voltage across switch S_4 is 190V and voltage across switch S_5 is 190V.

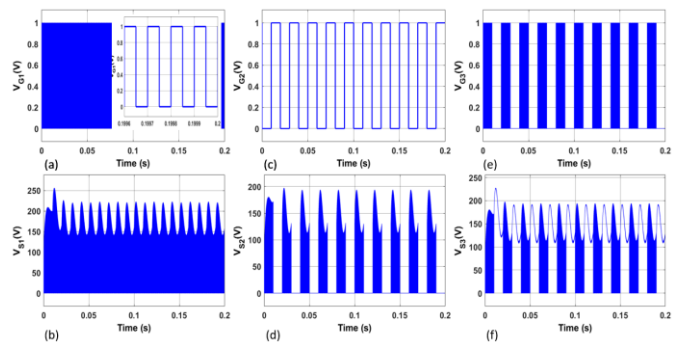

Fig -8: (a) Gate pulse to S_1 , (b) Voltage across S_1 (c) Gate pulse to S_2 , (d) Voltage across S_2 , (e) Gate pulse to S_3 , and (f) Voltage across S_3

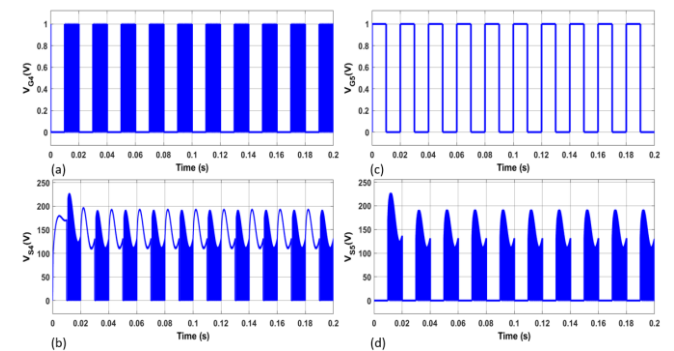

Fig -9: (a) Gate pulse to S_4 , (b) Voltage across S_4 , (c) Gate pulse to S_5 , and (d) Voltage across S_5

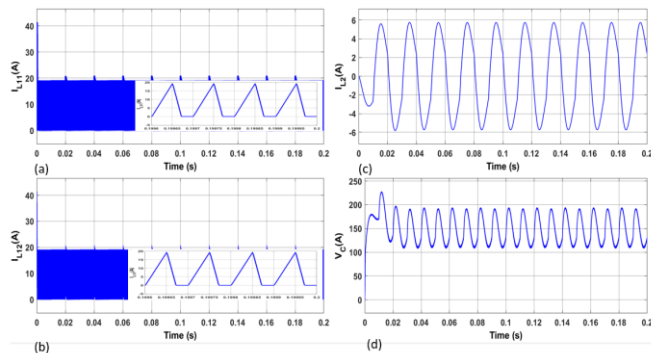

Fig -10: (a) Current through inductor L_{11} , (b) Current through inductor L_{12} , (c) Current through inductor L_2 and (d) Voltage across capacitor C

2. ANALYSIS

Efficiency of a power equipment is defined at any load as the ratio of the power output to the power input. The efficiency tells us the fraction of the input power delivered to the load. Chart 1 shows efficiency Vs output power curve for R load. The inverter efficiency 92% for switched inductor based buck boost inverter for R load.

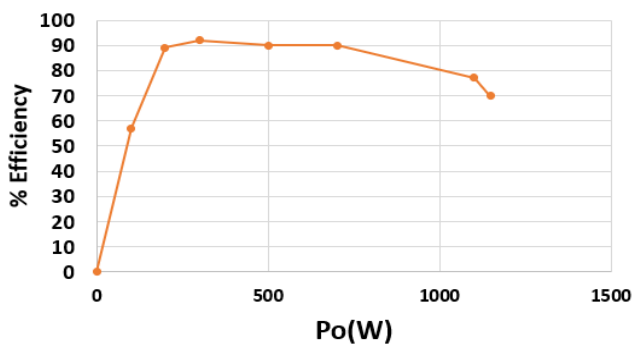

Chart -1: Efficiency Vs Output Power curve for R load

The plot of % THD of the inverter as a function of switching frequency is shown in Chart 2. Minimum THD was obtained at 10kHz of switching frequency.

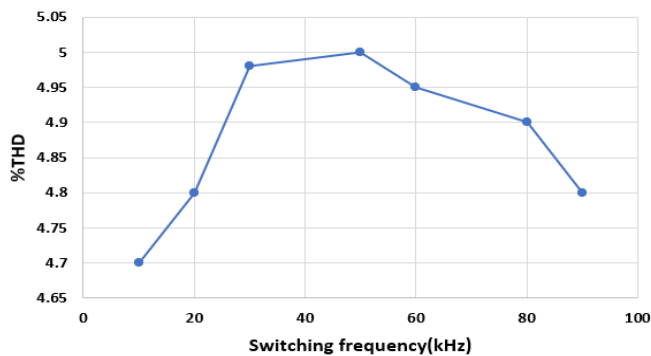

Chart -2: % THD Vs switching frequency

2. COMPARISON

Table 2 shows component wise comparison of different transformerless inverters. Even though switched inductor based buck boost transformer less inverter has more number of components, it has high gain.(SIBBTI-Switched Inductor based Buck Boost Transformerless Inverter)

Table -2: Sample Table format

Parameters	SIBBTI	[1]	[4]	[3]
No of switches	5	5	6	5
No of diodes	4	1	0	2
No of inductors	3	2	1	2
No of capacitors	1	1	1	0
Total no of components	12	9	8	9

2. EXPERIMENTAL SETUP WITH RESULT

Dspace controller is used for generating switching pulses for each switch. The pulses from microcontroller which is about 5 V is amplified by driver circuit that consist of TLP250H. Driver circuit produces pulse of 12 V for driving the switch. The controller output and the driver output is shown in figure 11. Switches S_1, S_3 and S_4 have a frequency of 10kHz and other switches S_2 and S_5 with frequency 50Hz.

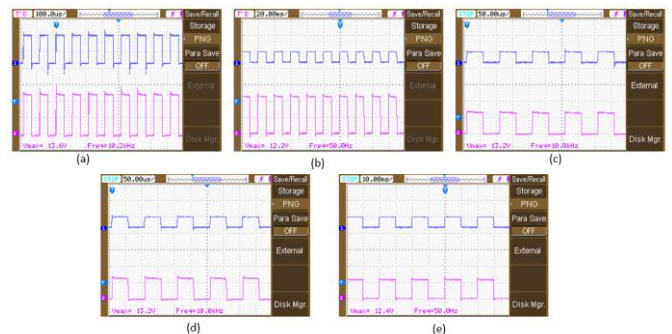

Fig -11: Pulse for switch (a) S_1 , (b) S_2 , (c) S_3 , (d) S_4 , (e) S_5

The output of 7.6V,50Hz is obtained from hardware setup as shown in figure 12(a) and output waveform is shown in figure 12(b).

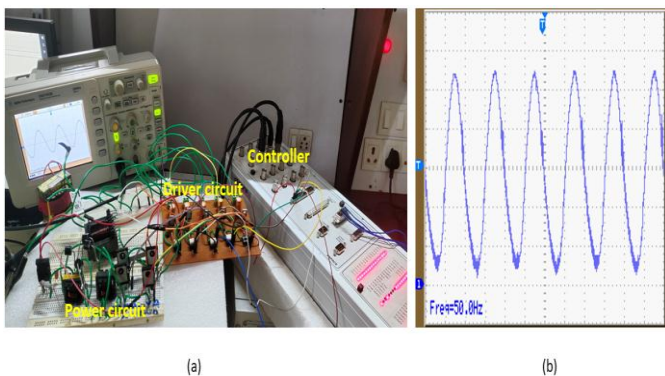

Fig -12: (a)Hardware setup, (b)Output

IEEE 42nd Photovolt. Spec. Conf., New Orleans, LA, USA, Jun. 2015, pp. 15.

- [5] Li Yunxia, Zhang Q and Yu Qiao, "Cascaded quasi-Z source inverter based on switched-inductor", IEEE 3rd International Electrical and Energy Conference, vol. 32, no. 7,2013.

3. CONCLUSION

Switched inductor based buck-boost transformerless inverter topology was analyzed and validated through simulation results. Buck boost transformer inverter topology injects zero leakage current and negligible DC current grid-connected PV application. Due to the buck-boost property the maximum power point can be tracked for PV under the wide voltage variation. The inverter was tested at the switching frequency of 10kHz and it has been observed that switched inductor concept improved its gain and efficiency. The control of the proposed inverter is implemented using dSPACE DS1104. Inverter prototype of 5W provides the expected performance with an output voltage of nearly 8V. The overall analysis confirms that the proposed inverter can be used in applications such as photovoltaics, micro grids, electric vehicles etc.

REFERENCES

- [1] Phani Kumar Chamarthi, Mohamed Shawky El Moursi, "A Novel Single-Stage Buck-Boost Transformerless Inverter for 1 ϕ - Grid-Connected Solar PV Systems", IEEE Conference on Applied Power Electronics Conference and Exposition (APEC), vol. 24, June 2020.
- [2] V. Agarwal and S. Jain , "A single-stage grid-connected inverter topology for solar PV systems with maximum power point tracking", IEEE Trans. Power Electron., vol. 22, no. 5, pp. 19281940, Sep. 2007.
- [3] T. Sreekanth, N. Lakshminarasamma, and M. K. Mishra, "A single-stage grid-connected high gain buck-boost inverter with maximum power point tracking", IEEE Trans. Energy Convers., vol. 32, no. 1, pp. 330339, Mar. 2017.
- [4] P. Chamarthi, M. Rajeev, and V. Agarwal, "A novel singlestage zero leakage current transformerless inverter for gridconnected PV systems", in Proc.