

# Autonomous Car using Arduino

Shambhavi Lalsinge<sup>1</sup>, Yash Mali<sup>2</sup>, Akshit Mahale<sup>3</sup>, Mrunmayee Kulkarni<sup>4</sup>, Omkar Kurade<sup>5</sup>,  
Professor. Pramod Patil<sup>6</sup>

\*\*\*

**Abstract** - We propose a model of a self driving car which is analogous to an actual self driving car, but is a simpler and value effective version. This model will help students to understand the working of an actual autonomous car. This model can also help in solving some real world problems. Using the logic and algorithm used in this model, in any other vehicle such as a wheel chair can make it autonomous and help the user to operate it without anyone else's help. Also, hardware architecture is described which may be tweaked in step with the need.

**Key Words:** Arduino, self driving car, Autonomous, ultrasonic sensor, motor, batteries, object detection, obstacle detection.

## 1. INTRODUCTION

Autonomous vehicles are generating significant attention and discussion, since recently every automobile company is working to develop their respective autonomous vehicle concept and many are getting successful in achieving some levels of autonomy and are planning to start production of autonomous vehicles in few years. Even though people are not yet sure and still have mixed feelings of excitement and insecurity regarding the autonomous concept but they will either accept it or reject it on the basis of the impacts of autonomous vehicles, such as safety, etc. Researchers and analysts from various universities and companies around the world have already started considering the consequences of autonomous vehicles on carbon emission, number of cars per person, safety of the people sitting in car etc. and are providing their insights on driverless car concept. Self-driving cars will need to outperform human driving capabilities for securing a larger consumer market. Surely, it will have a huge impact on the timeline of transportation and it will completely change the way of people's thinking towards future technologies.

## 2. LITERATURE SURVEY

The development of the autopilot airplanes was a big step in human history towards any type of vehicle automation. This invention has set the pillars for the innovation of the self driven cars. From the year 1920, researchers have been working on solving the challenge to build driverless autonomous cars. During the year 1926, Lihirrican Wonder used radio antennas to send radio impulses which were further caught by the antennae. The antennae introduces the signal to circuit breakers which operate small electric motors that direct every movement of the car. This was the first step in the innovation of autonomous cars. Currently, Tesla has successfully implemented the concept of driverless cars.

In the paper, "Self-driving car to demonstrate real time obstacles & object detection." by Mayur Bhangale, Gaurav Dabhade, Akshay Khairnar, Mamta Bhagat, a model of an autonomous car has been proposed which uses an Arduino along with Raspberry pi for processing. For obstacle detection they have used ultrasonic sensor and for path detection they have used camera which does real time image processing.

In the paper "The key technology toward the self-driving car" by Jianfeng Zhao, Bodong Liang and Qiuxia Chen, the paper analyzes the key technology of self-driving car and illuminates the state-of-art of the self-driving car.

In the paper "Autonomous Vehicles: Levels, Technologies, Impacts and Concerns" by Mohsin Raza, the author has demonstrated the various technologies that can be implemented in self-driving cars. These technologies are stated according to levels of IOT. The author has also defined the various impacts of self driving car and concerns regarding this.

In the paper "Self-Driving and Driver Relaxing Vehicle" by Qudsia Memon, Muzamil Ahmed, Shahzeb Ali, Azam Rafique Memon, Wajiha Shah. This paper states a model of self driving car which uses a GPS module along with a GSM module. This model analyses another car in front of itself and analyses its movements. So it keeps following the another car with the help of ultrasonic sensor.

## 3. METHODOLOGY

### 3.1 Components and Design

#### Arduino Uno:

It is a type of microcontroller that works with ATmega328P. It is used for processing the data received from the sensors and give accurate commands to the actuators according to the input received.

#### Servo Motor:

It is a type of actuator that allows to control the angular position control precisely. It contains a motor that coupled with a sensor that helps for the proper position feedback.

#### Motor Driver Circuit:

An arduino pin is able to deliver only 40mA current but a DC motor requires more current so we use Motor Driver. It is like a current amplifier which drives the motor according to signals from the arduino.

**Gear Motor:**

A gear motor is basically a combination of a motor with a reduction geartrain. The geartrain is used to reduce the speed of the motor with an increase in torque.

**Ultrasonic Sensor:**

An ultrasonic sensor is a sensing device that helps to measure the distance of an object around it with the help of ultrasonic waves.

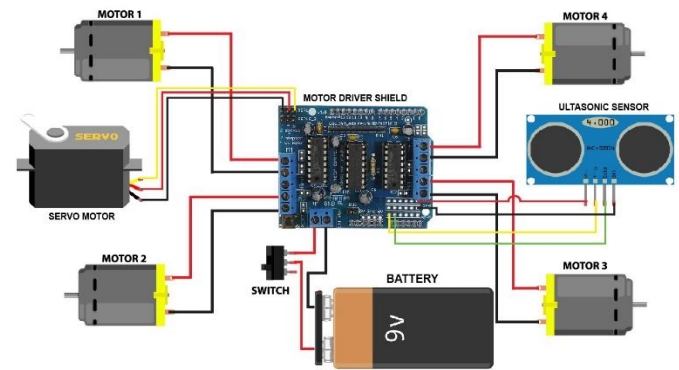

**Fig-1:** Circuit diagram of the components

**3.2 Algorithm**

According to the flowchart in fig 2, the basic condition for movement of the car will be distance which will be sensed with the help of ultrasonic sensor. So we will be specifying the distance according to which, it will decide to move forward, backward, left, right or stop. The degree of freedom of the ultrasonic sensor is increased with the help of servo motor, since the ultrasonic sensor is mounted on the servo motor. So, the ultrasonic sensor will also sense the distance to its left and right and change the path accordingly.

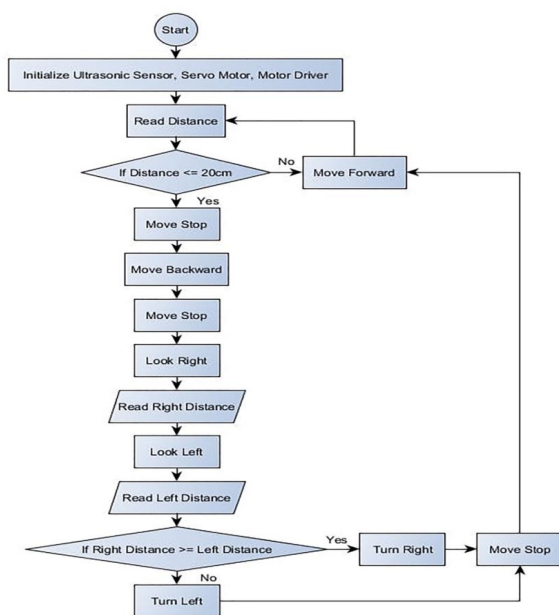

**Fig-2 :** Flowchart for working of the car.

**4. RESULTS AND DISCUSSIONS**

The project has been tested and found working smoothly in figure 3, 4. When we turn on the switch, the ultrasonic sensor starts collecting data of the surroundings and sends it to the Arduino. The Arduino collects the data and processes it. After processing it sends signals to the gear motors. The gear motors then help the car to move according to the commands sent by the Arduino.



**Fig-3 :** Prototype of the car

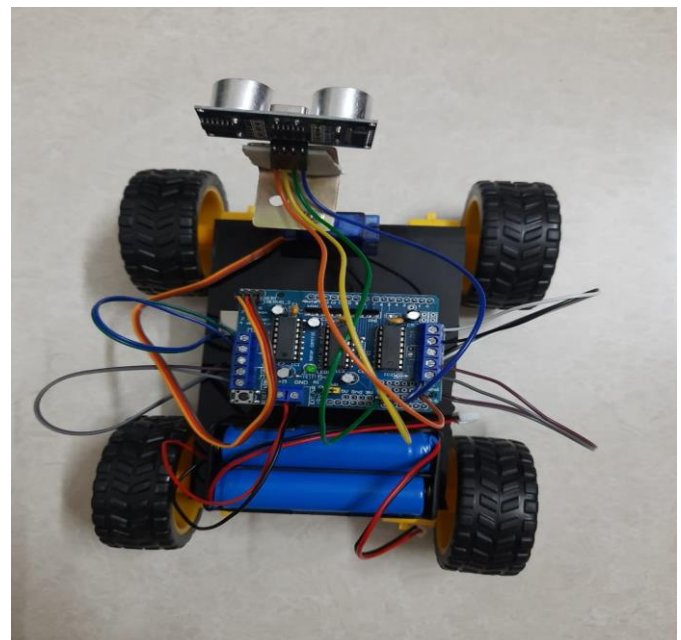

**Fig-4 :** Top view of the car.

The car will first sense the distance of the nearest object, which is defined in the code. It will check if the distance satisfies the condition defined in the code and change the path accordingly either to right or left, or it can also move in

the backward direction and sense for the objects again.

## 5. CONCLUSIONS

According to all the results discussed in this paper, we conclude that the car uses ultrasonic sensor to calculate the distance and detect the obstacles around it and is also capable of taking it's own decisions regarding changing the directions to make a movement. The vehicle routes itself with the help of input from the ultrasonic sensor. The input from the ultrasonic sensor is passed to arduino where it is processed and then the commands by the arduino are passed to the motors. In this way the car operates and takes decisions to move in any of the directions.

## REFERENCES

- [1] Mayur Bhangale, Gaurav Dhabade, Akshay Khairnar, Mamta Bhagat "Self Driving car to demonstrate real time obstacles and object detection" International Research Journal of Engineering and Technology Volume 03 Issue: 11 Nov-2016.
- [2] Mohsin Raza "Autonomous Vehicles: Levels, Technologies, Impacts and Concerns" International Journal of Applied Engineering Research Volume 13, Number 16 (2018).
- [3] Jianfeng Zhao, Bodong Liang, Quixia Chen "The key technology towards self-driving car" IJIUS 2017.
- [4] Shahzeb Ali, Azam Rafique "Self-Driving and Driver Relaxing Vehicle" ICRAI November-2016
- [5] Shubh Srivastava, Rajanish Singh "Voice Controlled Robot Car Using Arduino" International Research Journal of Engineering and Technology Volume: 07 Issue: 05 May 2020