

Real and Reactive Power Compensation by using Diode Clamped Multilevel Inverter based STATCOM

Dr. T. Murali Mohan¹, G. Manohar Brahmam²

¹Professor, Department of Electrical and Electronics Engineering, UCEK, JNTU Kakinada, India

²M.Tech, Department of Electrical and Electronics Engineering, UCEK, JNTU Kakinada, India

Abstract - At present static compensators (STATCOM) are playing major role in the maintaining the voltage stability of the transmission lines. To reduce the ripple content in the output waveform of the STATCOM multilevel inverter topologies are used. The major requirement of the reactive power demand for inductive type of load is to mitigated by STATCOM to reduce the burden along with the reactive power, real power is also required to be provided to reduce the effect of voltage drop being caused by the resistance of the Transmission lines. STATCOM is a power electronics based shunt connected compensating device which proves to be very useful to provide reactive and real power compensation in the distribution line. In this paper, using STATCOM with the integration of Diode clamped three level multilevel inverter is used to supply both real and reactive power. The results are verified MATLAB/SIMULINK a transmission line of 25KV s is used and with STATCOM rating of +/- 1 MVA is used. The results shows that the multilevel inverter maintains voltage stability of the load with less harmonic content in voltage waveforms

Key Words: Power quality, voltage sag, Voltage swell, STATCOM, Multilevel inverter, Diode clamped multilevel inverter, Simulink

1. INTRODUCTION

The exponential growth in the electrical energy usage day by day, combined with demand for low cost energy, has gradually led to the development of generation sites remotely located from the load centre. The usage of transmission lines to connect generating sites to load centres is required for the generation of bulk electricity at remote places. Active regulation of reactive power is required to stabilise the power system and sustain the supply voltage with long-distance ac power transmission and load power requirement. The static synchronous compensator (STATCOM), which uses voltage source inverters instead of thyristor-controlled reactors, has been approved as a competitive alternative to the traditional static var compensator (SVC). STATCOM acts as a synchronous voltage source. It can provide reactive power compensation without the dependence on the ac system voltage. By controlling the reactive power, a STATCOM can stabilize the power system, increase the maximum active power flow and regulate the line voltages. Faster response makes STATCOM suitable for

continuous power flow control and power system stability improvement [1]. The interaction between the AC system voltage and the inverter-composed voltage provides the control of the STATCOM var output. When these two voltages are synchronized and have the same amplitude, the active and reactive power outputs are zero. There are various converter configurations available for both single and three phase applications:-The single phase half bridge is a one-leg convertor consisting of two switching elements. The H- bridge VSC is most popular for single phase applications because with the same DC input voltage the output of the full bridge is twice that of the half bridge. Numerous mechanical applications have started to require high power as of late. Some machines in the ventures anyway require medium or high power for their activity. Utilizing a powerful hotspot for every single mechanical load may end up being valuable to a few engines requiring high power while it might harm alternate burdens. Inverters are utilized for some applications, as in circumstances where low voltage DC sources must be changed over with the goal that gadgets can keep running off of AC control. The staggered inverter has been presented since 1975 as option in high power and medium voltage situations the staggered inverter resembles an inverter and it is utilized for modern applications as an option in high power and medium voltage circumstances. The staggered inverter comprises of a few switches. In the staggered inverter the game plan switches edges are critical. Multilevel inverter goes up to high exchanging voltage by methods for a progression of voltage steps, every one of which is rely upon the rating of intensity gadgets separately. For staggered inverter, a few topologies are ordered in two gatherings relying upon the quantity of autonomous dc source. The most well-known working topologies are diode clipped (NPC), flying capacitor (FC) and Cascaded H-Bridge (CHB). A NPC inverter is fundamentally made out of two ordinary two-level voltage source inverter stacked are over the other with some minor adjustments. This paper shows the regulation of voltage across the load with both simultaneous control of real and reactive power control [2].

2. STATIC SYNCHRONOUS COMPENSATOR (STATCOM)

The basic structure of the STATCOM is converter that produces a synchronous sinusoidal voltage. Voltage source Inverter (VSI) are mostly used in the application of the

statcoms. The most economical and practical configuration that is presently utilized and suggested.

High power utility applications are multiphase converters. The real power supplied by the dc link capacitor is zero, thus it supplies only the required reactive power depend upon the control phase and magnitude of the gating pulses of the statcom since reactive power at zero frequency i.e. Capacitor voltage is by definition zero, the dc capacitor has no influence in the responsive power age. In other words, the reactive power generation is due to the interconnection of the AC phases by the converter in such a way that the reactive power of the AC system can flow freely from the AC phases. Nonetheless, despite the fact that reactive power is inside created by the activity of solid-state switches, it is as yet important to have some somewhat little dc capacitor across the terminals of the converter [3].

The requirement for the dc capacitor is principally needed to fulfil the balance between the input and output powers of the converter. The result voltage waveform of the converter is not an ideal sine wave, smooth wave nearly too sinusoidal current is achieved through the use of multilevel topologies in the statcom through the tie reactance of the transmission system. As a result of reduced ripple content in the output waveform the net three phase power has less ripples.

2. 1. Basic operation of STATCOM

From Fig. 1 shows that STATCOM consists of a power electronic device which converts the D.C to the A.C known as the inverter generally three phase inverter (generally a PWM inverter) using SCRs, MOSFETs or IGBTs, a dc capacitor which provides the dc voltage for the inverter, a transformer which acts as a leakage inductance which plays major role in reactive power flow. From the dc side capacitor, a three phase voltage is generated by the inverter. This is synchronized with the ac supply. The leakage inductor links the inverter D.C voltage to the ac supply side. The basic principle of operation of STATCOM is that, for two ac sources which have the same frequency and are connected through a series inductance, the active power flows from the leading source to the lagging source and the reactive power flows from the higher voltage magnitude source to the lower voltage [2].

In conventional converters which is two level inverter they do not have the capability of voltage magnitude control and only the phase angle of the AC output waveform can alone be controlled by the gating pulses of the statcom. But in multilevel inverter there is a capability of controlling both the magnitude of the AC output waveform and phase angle of the output AC voltage waveform Voltage (V_s) is the AC voltage generated from the statcom and the transmission system voltage (V_t). If V_s lags V_t , real power flows from transmission system to dc side. Similarly if V_s leads V_t , real power flows from the dc side to the transmission system.

Therefore the real power exchange is a function of phase displacement ($\Delta\alpha$).

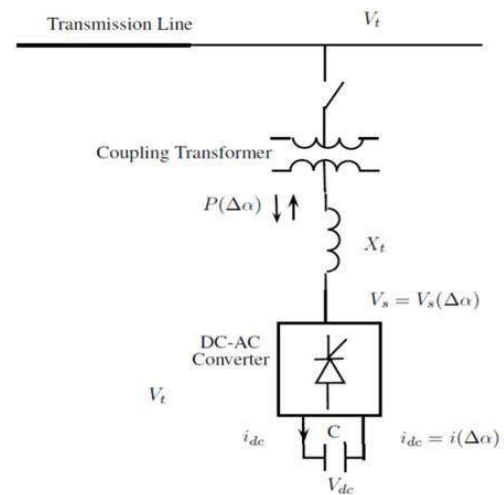

Fig -1: Block diagram of STATCOM

2.2. Power flow equations of STATCOM

Diode clamped MLI based STATCOM is connected to the line through coupling transformer. The VSC and a capacitor connected at DC side. Here a three level diode clamped MLI is used as statcom as shown in fig 2.

The current flowing from the statcom is derived from the equation below as,

$$I_c = (V_c - V_s) / x \tag{1}$$

Active power from the statcom is given by the equation as follows

$$P = (V_c * V_s / x) * \sin \alpha \tag{2}$$

Reactive power from the statcom is given by the equation as follows

$$Q = (V_c^2 - V_c V_s * \cos \alpha) / X \tag{3}$$

Where

V_c is the inverter output AC voltage

V_s is the AC bus voltage

X is the leakage reactance of coupling transformer

α is the phase angle between V_s and V_c

I_c is the magnitude of STATCOM current injecting into the system.

From the above equations (1), (2), (3) it represents the power flow equations from the statcom.

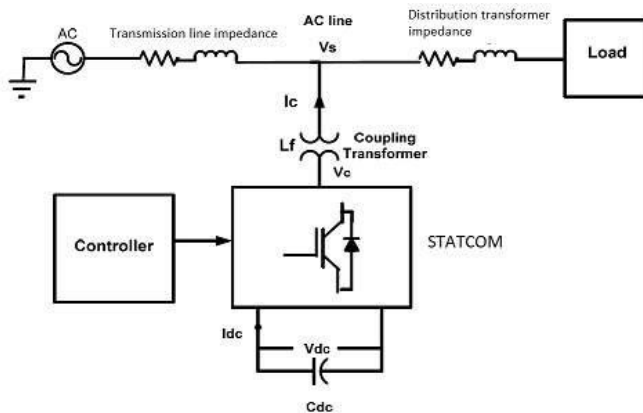

Fig-2: Schematic diagram of STATCOM with power system

From the equation (2) it shows that, the active power flow from the statcom is positive when grid voltage leads the statcom voltage vice versa the active power flow from the statcom is made negative by making grid voltage lags the statcom voltage i.e., statcom supplies real power to the grid.

From the equation (3) it shows that, the reactive power flow from the statcom is made positive when grid voltage magnitude is larger than the statcom voltage magnitude, vice versa the reactive power flow from the statcom is made negative by making grid voltage magnitude less than the statcom voltage i.e., statcom supplies reactive power to the grid [3].

3. Multilevel inverter topologies

There are mainly three different multilevel converter structures are widely used in industrial applications.

They are

- i. Diode clamped inverter
- ii. Flying capacitor multilevel inverter
- iii. Cascaded H-bridge converter with separate dc sources.

The circuit design is more complex, as the presence of large number of switches in the circuit, the control of the switches in circuit is complicated to obtain the output voltage of different levels with smoother output waveforms. The obtained waveform has decreased harmonic distortions and change in voltage per second across each switch is reduced.

Diode clamped inverter which is also commonly called as neutral fed inverter is most commonly used multilevel inverter, to achieve steps in output voltage the diode is used as clamping device which is helpful to clamp the dc bus bus voltage to get different levels. Thus, diode is used to limit the voltage stress. In this topology there are two pairs of switches and two diode are consists in a three-level diode clamped inverter. The voltage across each capacitor and each switch is

V_{dc} . The quality of the output voltage is improved by increasing the number of voltage levels and the voltage waveform becomes closer to sinusoidal waveform. The diodes used to provide access to mid-point voltage and all switch pairs work in complimentary mode. The DC bus voltage is divided into three voltage levels with the help of two series connections of DC capacitors, C_1 and C_2 . With the assistance of the clamped diodes the voltage stress across each power electronic switch is inclined toward V_{dc} . It is assumed that the absolute dc link voltage is V_{dc} and mid-point is synchronized at half of the dc interface voltage, the voltage across every capacitor is $V_{dc}/2$ ($V_{c1}=V_{c2}=V_{dc}/2$). In a diode clamped three level inverter, there are three unique possible switching states. Only two switches is on for a three-level inverter at any instant of time [6].

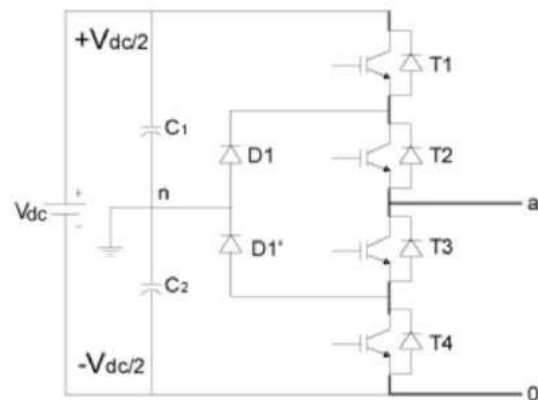

Fig-3: Single leg of three level Diode clamped multilevel inverter

Table -1: Switching states of DC-MLI

Switch State	State	Pole Voltage
T1=ON,T2=ON T3=OFF,T4=OFF	S=+VE	$V_{ao}=V_{dc}/2$
T1=OFF,T2=ON T3=ON,T4=OFF	S=0	$V_{ao}=0$
T1=OFF,T2=OFF, T3=ON,T4=ON	S=-VE	$V_{ao}=-V_{dc}/2$

At any time a set of two switches is on for a three-level inverter. Table.1 shows the switching states in one part of the three-level diode clamped multilevel inverter. In a three level diode clamped inverter, there are three altered achievable switching states which are allowed to obtain the stepped waveform nearer to sine wave on output voltage relating to DC link capacitor voltage value.

3.1. Switching configuration of Diode Multilevel inverter topologies

During the triangular carrier wave comparison two high frequency triangular waves are used to compare with the reference sine wave, if the reference phase signal is greater than the two triangular carrier waves then the T1, T2 switches are turned on and T3, T4 switches are turned off on producing the output voltage as $V_{dc}/2$. If the reference phase signal is not greater than above triangular wave and greater than below triangular wave then T1, T4 switches are turned off, T2, T3 switches are turned on. If the reference phase signal is not less than above triangular wave and not less than below triangular wave then T1, T4 switches are turned off, T2, T3 switches are turned on. If the reference phase signal is less than both the triangular carrier waves then T1, T2 switches are turned off and T3, T4 switches are turned on producing output voltage as $-V_{dc}/2$ [6].

The output voltage obtained by the above switching configuration is obtained as shown in below figure. The circuit diagram representing above switching is shown in below figure.

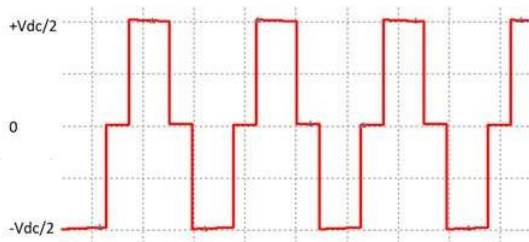

Fig -3: Output waveform voltage for a single phase

3.2. PI controller

The block diagram of a proposed control technique is shown in fig.4. Therefore, the PLL provides the angle ϕ to the abc-to-dq0 (and dq0-to-abc) transformation. There are also four proportional-integral (PI) regulators.

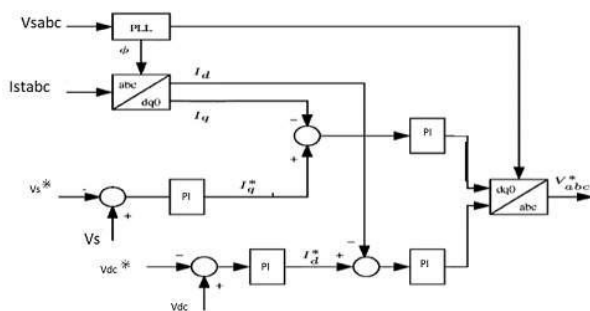

Fig -4: D-Q control strategy

Figure 4 shows the internal view of Synchronous Reference Frame Theory (SRF) control strategy for STATCOM. In this control strategy the SRF-based STATCOM

control technique is used to generate gate pulses for controlling of STATCOM. Here from the control strategy is designed with abc frame to d-q frame conversion block, PLL block, HPF, PI controller, DQ to ABC conversion block. The abc frame to d-q frame conversion block converts 3ϕ load current parameters (I_{abc}) to dq0 parameters frame by using parks transformation. The phase locked loop generates $\sin\omega t$ and $\cos\omega t$ signals for transformation block. Initially, the current components from block in $\alpha-\beta$ co-ordinates are generated. I_{abc} of statcom current phases can then be transformed into $\alpha-\beta$ coordinates. HPF is high pass filter is used to block low frequency components coming from conversion block then given to inverse transformation block and then the output of inverse transformation block is STATCOM reference current which will generate gate pulses for switches [4].

3.3. Design of PI controller

In this paper, simulation is done by using proportional-integral (PI) controller. The DC reference voltage and DC link voltage are compared and the error is generated and controlled by PI controller which generates the direct axis component of the reference grid current. The grid reactive power and reference reactive power (reference grid reactive power, $Q_{ref} = \text{zero}$) are compared and controlled by PI controller which generates quadrature axis component of reference grid current as shown in Figure 4.

The controller used is discrete PI controller that takes reference value and actual value and generates the maximum value of reference current, which depends on the errors in the reference value and actual value.

The voltage error $V(n)$ is given as:

$$V(n) = V^*(n) - V(n-1) \tag{4}$$

The output of the PI controller at the nth instant is:

$$I(n) = I(n-1) + K_p * [V(n) - V(n-1)] + K_i V(n) \tag{5}$$

The equations of direct and quadrature axis component of reference grid current are,

$$I_d = \left(K_p + K_i/s \right) * \left(V_{ref}^* - V \right) \tag{6}$$

$$I_q = \left(K_p + K_i/s \right) * \left(V_{dc}^* - V_{dc} \right) \tag{7}$$

Where

K_p proportional gain

K_i integral gain

V_{dc}^* reference DC link voltage

V_{dc} measured DC link voltage

V_{ref}^* reference load voltage

V measured load voltage

4. MODELING THE STATCOM USING THE SIMULINK'S POWER SYSTEM BLOCKSET

A STATCOM is a power electronic system with a complex control system. Modelling the STATCOM including the power network and its controller in Simulink environment requires "electric blocks" from the Power System Block set and control blocks from Simulink library. We consider here a +1Mvar STATCOM connected to a 25-kV distribution network.

Figure 5 shows a Simulink diagram which represents the STATCOM and the distribution Network. The feeding network is represented by a Thevenin equivalent (bus B1) followed by a 21-km feeder which is modelled by a pi-equivalent circuit connected to bus B2. A 25-kV/2500 V transformer and a 100 MVA load are connected to bus B2 by a 2-km feeder. The STATCOM output is coupled in parallel with the network through a step-up 2.5/25-kV Y-Y transformer. The primary of this transformer is fed by a voltage-source PWM inverter consisting of two IGBT bridges. A filter bank is used at the inverter output to absorb harmonics. A 6600 micro farads capacitor is used as dc voltage source for the inverter.

APWM pulse generator with a carrier frequency of 2kHz is used to control both IGBT bridges. The modulation scheme used is of Level shift sinusoidal type Pulse width modulation.

Table -2: System parameters and values

System Parameters	Values
Source voltage	25000 volts
Transmission line rating	25kv /100 MVA
Transmission line impedance	0.1 p.u resistance, 1 p.u reactance
Distribution Transformer	25kv/415 volts
R-load	70e6 MW
RL - Load	52.5e6 MVAR
RC-Load	-52.5e6 MVAR

4. 1 SIMULATING THE STATCOM OPERATION MODELING THE STATCOM USING THE SIMULINK'S POWER SYSTEM BLOCKSET

The Simulink diagram shown in Fig. 5 has been used to simulate the operation of the D-STATCOM under different conditions to illustrate its performance. The simulation was done using a discrete step time (T = 50 micro seconds). Initially the statcom is in open state. As there will be variations in the voltage of the transmission system it is simulated in the Simulink by using programmable voltage source.

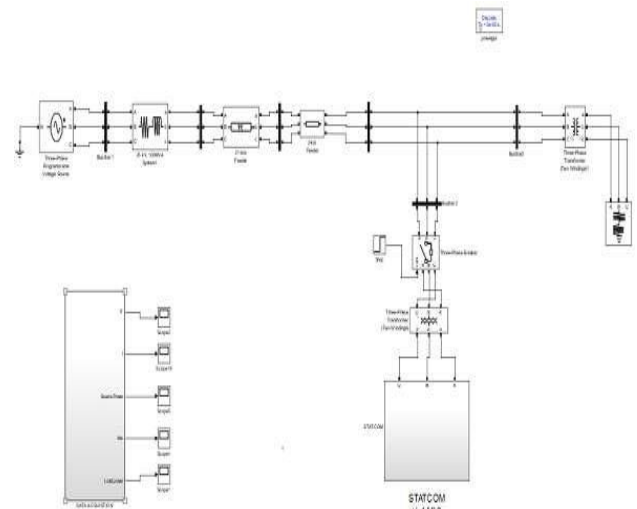

Fig -5 Simulink diagram representing STATCOM

The simulation is done under variation types of load such as RL Load, RC Load, and R Load. The behavior of the statcom under correction of the load voltage is observed during the both cases such as Voltage Sag which from 1 p.u to 0.98 p.u and Voltage Swell which is from 1 p.u to 1.02 p.u.

4. 1 When under RL Load

A RL load of 100 MVA consisting of 70MW of resistive load and 52.5 MVAR of inductive load is considered to be as a load. The STATCOM operation at load side for different conditions such as decrease in voltage ie., voltage sag and increase in the voltage ie., voltage swell are to be tested.

4. 1. 1 Voltage Sag

As there will be variations in the voltage of the transmission system it is simulated in the Simulink by using programmable voltage source, where it is programmed to it voltage from 1 p.u voltage to 0.98 p.u voltage results in the voltage sag at time of 0.3 seconds. The decreased in the voltage can be observed from the power waveforms of the Source. The statcom is connected to the transmission system at the 0.5 seconds to increase the voltage at load to 0.98 p.u from the 1 p.u by the proper action taken by statcom.

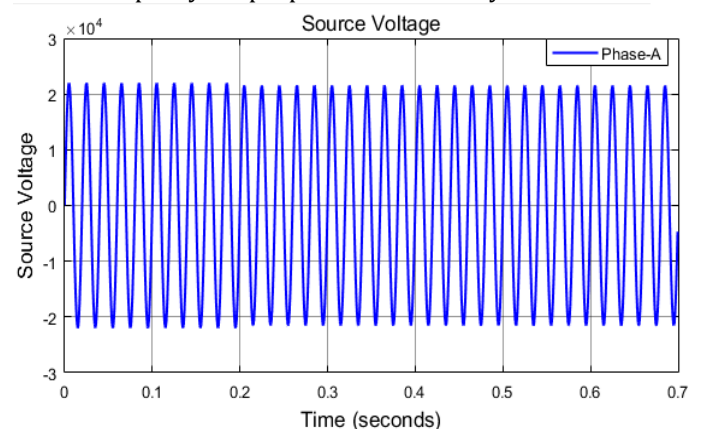

Fig -6.1.1-Source Voltage

At time $t=0$ sec, the voltage of the source is at 1 p.u. After 0.2 sec, the voltage is reduced from its 1 p.u to 0.98 p.u. it can be observed from the above waveform.

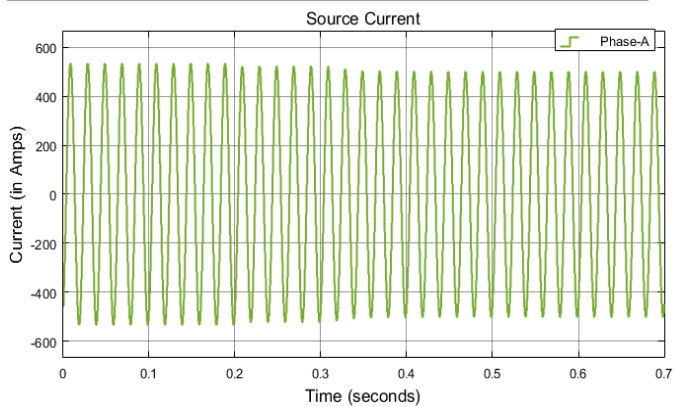

Fig -6.1.2-Source Current

At time $t=0$ sec, the current drawn from source is at normal value, at $t=0.2$ sec there is decrease in value due to decrease in voltage. After 0.3 sec, the statcom connection to the system made the system to draw less current than it requires.

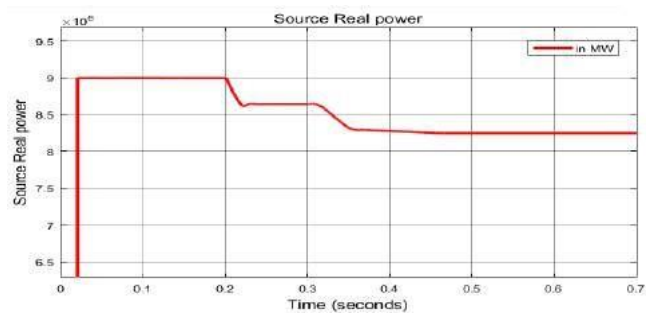

Fig -6.1.3-Source Real Power

At time $t=0$ sec, the real power drawn from the source is 9 MW after the connection statcom the real power drawn from the source is reduced to 8.2 MW.

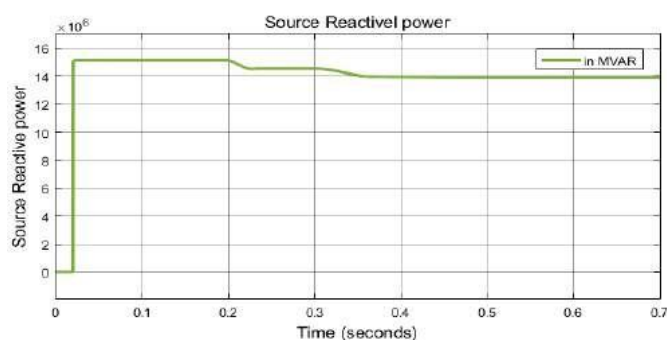

Fig -6.1.4-Source Reactive Power

At time $t=0$ sec, the reactive power drawn from the source is 15 MVAR, after connection of statcom at 0.3 sec the reactive power demand by the load is reduced by 1 MVAR.

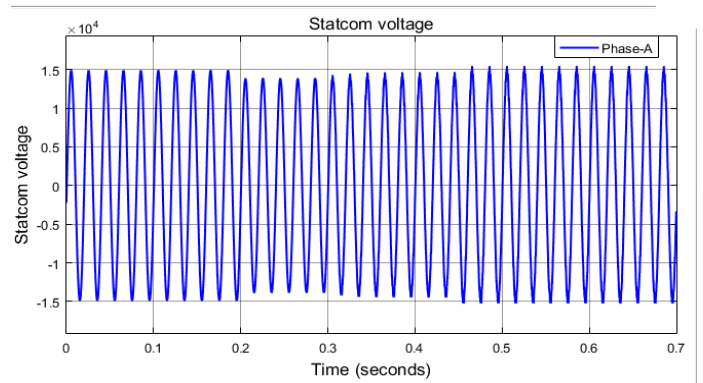

Fig -6.2.1-Statcom Voltage

At time $t=0$ sec, the statcom voltage is at value of 1 p.u. When time reaches 0.2 sec, there is decrease in the voltage to 0.98 p.u with the reduction of the voltage. At time $t=0.3$ sec, the statcom is made to connect and the voltage across the load is made to bring to the 1 p.u.

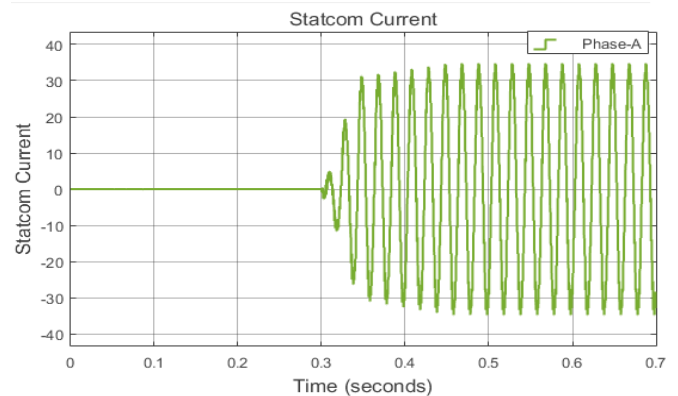

Fig -6.2.2-Statcom Current

At time $t=0$ sec, the power supplied by statcom is made to zero, when there is reduction voltage at load at $t=0.3$ sec the statcom makes the appropriate control action to supply required amount of power to load.

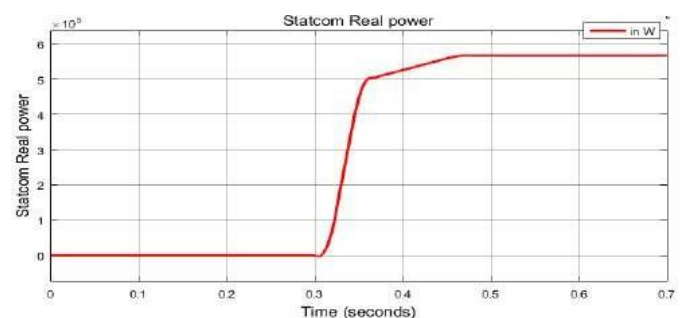

Fig -6.2.3-Statcom Real Power

At time $t=0$ sec, the statcom is in closed position. After $t=0.3$ sec, the statcom is made to connect to the load to produce the required amount of real power demanded by the load to maintain its value normal to 1 p.u.

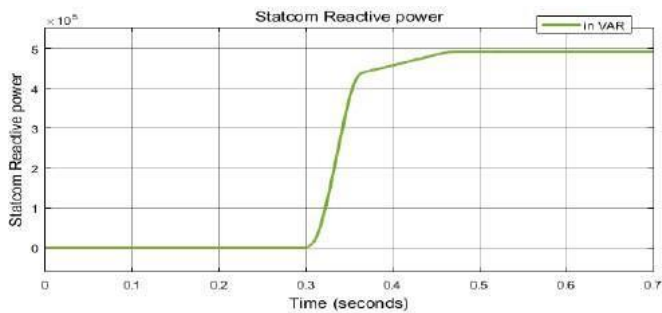

Fig -6.2.4-Statcom Reactive Power

At time $t=0$ sec, the statcom is closed position. After $t=0.3$ sec, the statcom is made to connect to the load to produce the required amount of reactive power demanded by the load to maintain its value normal to 1 p.u.

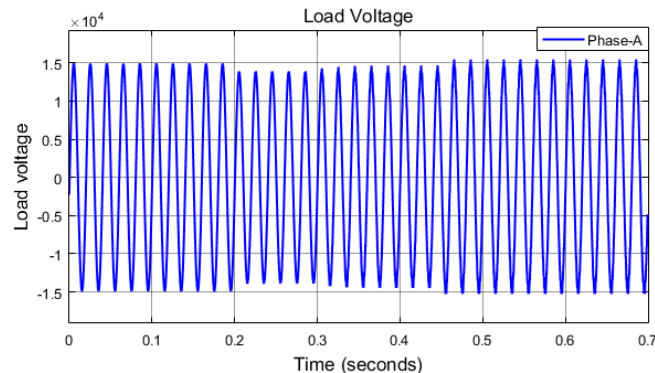

Fig -6.3.1-Load Voltage

Initially the voltage across the load is maintained at 1 p.u value, after 0.2 sec due to reduction in source voltage there is reduction in voltage value from 1 p.u to 0.98 p.u. At $t=0.3$ sec statcom is connected to bring back the voltage to 1 p.u. The statcom supplies the power demanded by the load which is reduced due to decrease in the voltage of the supply.

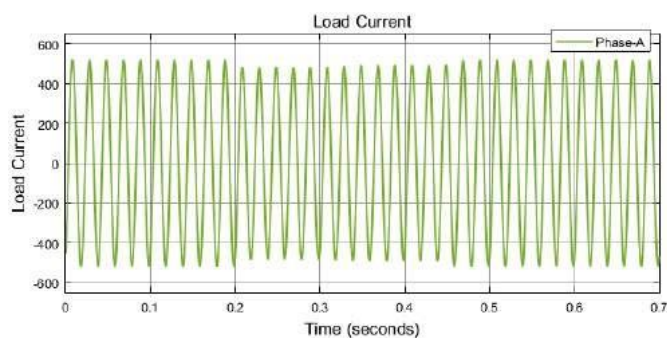

Fig -6.3.2-Load Current

At time $t=0$ sec, as the voltage across the load is made 1 p.u the load draws the required amount of current. As there is reduction in voltage at 0.2 sec, there is reduction in value of current. At 0.3 sec, the statcom is made to connect to load makes the load to draw the required amount of current.

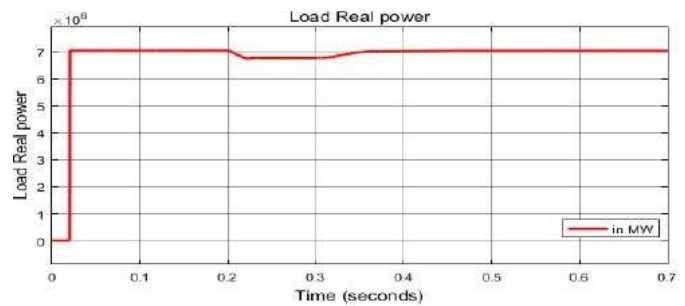

Fig -6.3.3-Load Real Power

It is observed from the wave form that at $t=0$ sec, the load is drawing its required power. After 0.2 sec there is decrease in power due to decrease in voltage, the statcom connected at 0.3 sec makes the load to draw the desired real power.

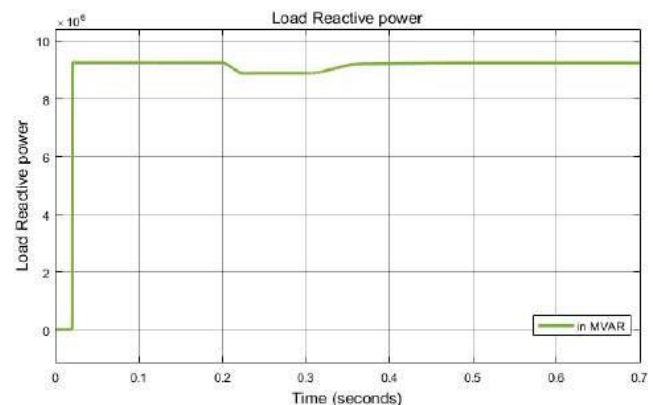

Fig -6.3.4-Load Reactive Power

It is observed from the wave form that at $t=0$ sec, the load is drawing its required power. After 0.2 sec there is decrease in power due to decrease in voltage, the statcom connected at 0.3 sec makes the load to draw the desired reactive power.

From the waveforms of the Figure 6 it is observed that the statcom is able to compensate both the active and reactive power by acting statcom as in the capacitive supplying both active and reactive power from the supply.

4. 1. 2 Voltage Swell

As there will be variations in the voltage of the transmission system it is simulated in the Simulink by using programmable voltage source, where it is programmed to increase voltage from 1 p.u voltage to 1.2 p.u voltage results in the voltage swell at time of 0.3 seconds. The increase in the voltage can be observed from the power waveforms of the Source. The statcom is connected to the transmission system at the 0.5 seconds to decrease the voltage at load to 1 p.u from the 1.2 p.u by the proper action taken by statcom.

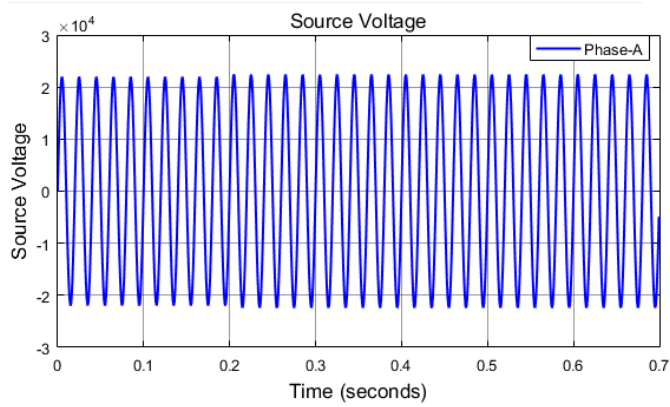

Fig -7.1.1-Source Voltage

At time t=0 sec, the voltage of the source is at 1 p.u. After 0.2 sec, the voltage is increased from its 1 p.u to 1.02 p.u. it can be observed from the above waveform.

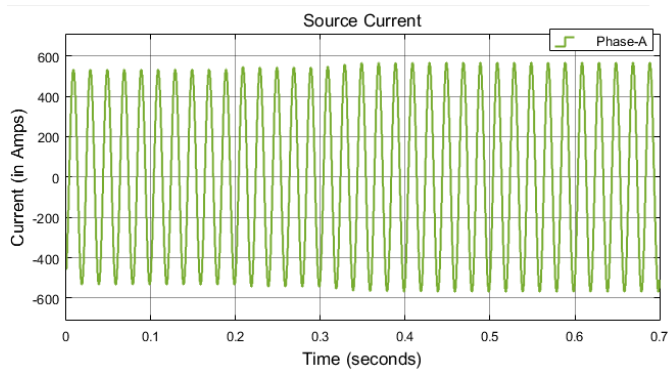

Fig -7.1.2-Source Current

At time t=0 sec, the current drawn from source is at normal value, at t=0.2 sec there is increases in value due to increase in voltage. After 0.3 sec, the statcom connection to the system made the system to draw more current than it requires to reduce more drop across lines to reduce voltage across the load.

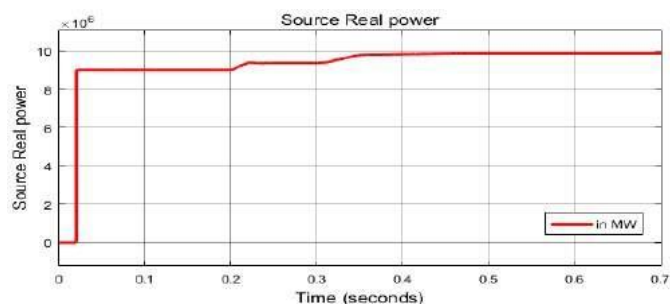

Fig -7.1.3-Source Real Power

At time t=0 sec, the real power drawn from the source is 9 MW after the connection statcom, the real power drawn from the source is increased to 10 MW.

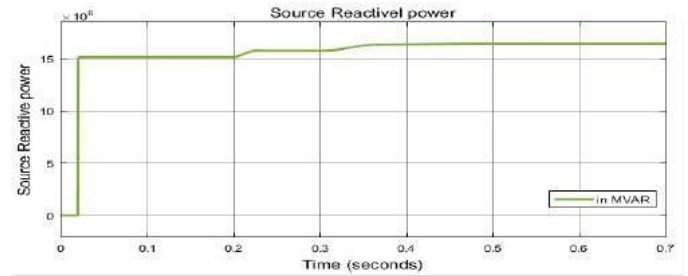

Fig -7.1.4-Source Reactive Power

At time t=0 sec, the reactive power drawn from the source is 15 MVAR, after connection of statcom at 0.3 sec the reactive power demand by the load is increased by 2 MVAR.

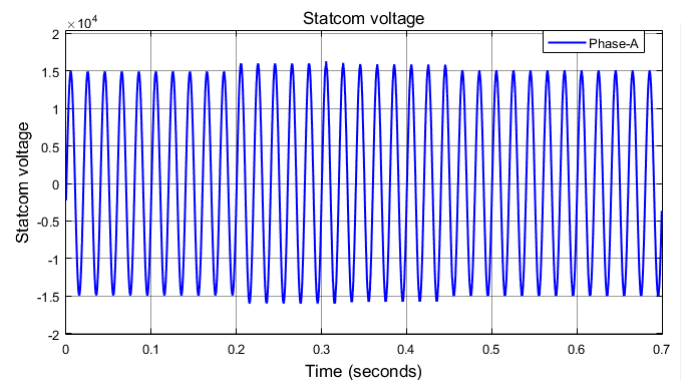

Fig -7.2.1-Statcom Voltage

At time t=0 sec, the statcom voltage is at value of 1 p.u When time reaches 0.2 sec, there is increase in the voltage to 1.02 p.u with the increase in the voltage. At time t=0.3 sec, the statcom is made to connect and the voltage across the load is made to bring to the 1 p.u.

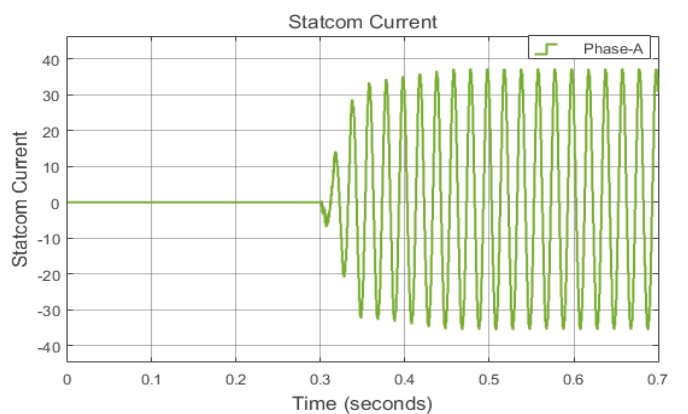

Fig -7.2.2-Statcom Current

At time t=0 sec, the power supplied by statcom is made to zero, when there is increase in the voltage at load at t=0.3 sec the statcom makes the appropriate control action to supply required amount of power to load.

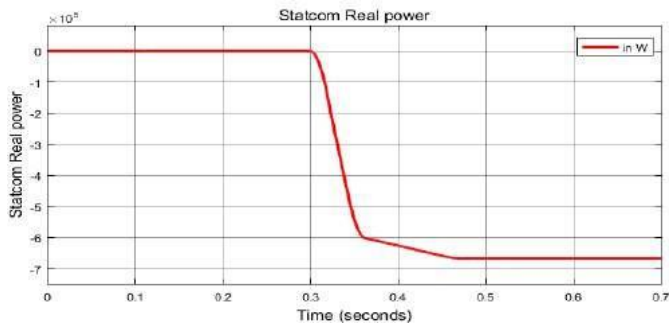

Fig -7.2.3-Statcom Real Power

At time $t=0$ sec, the statcom is closed position. After $t=0.3$ sec, the statcom is made to connect to the load to absorb the required amount of real power not required by the load to maintain it value normal to 1 p.u.

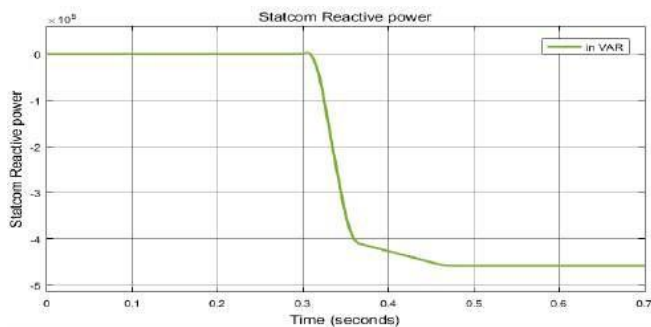

Fig -7.2.4-Statcom Reactive Power

At time $t=0$ sec, the statcom is closed position. After $t=0.3$ sec, the statcom is made to connect to the load to absorb the required amount of reactive power not required by the load to maintain it value normal to 1 p.u.

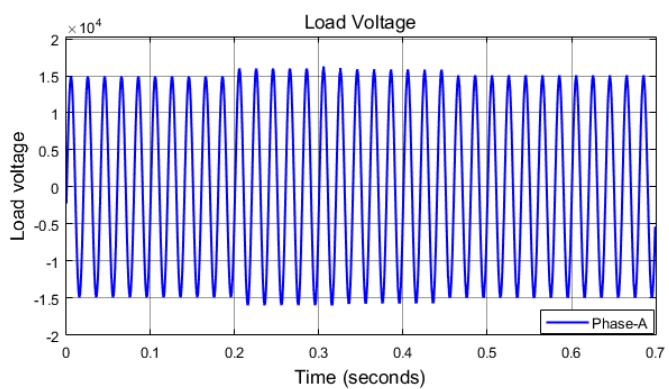

Fig -7.3.1-Load Voltage

Initially the voltage across the load is maintained at 1 p.u value, after 0.2 sec due to increase in source voltage there is increment in voltage value from 1 p.u to 1.02 p.u. At $t=0.3$ sec statcom is connected to bring back the voltage to 0.3 sec.

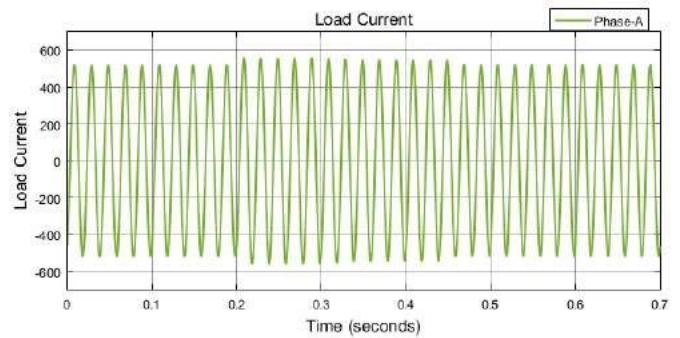

Fig -7.3.2-Load Current

At time $t=0$ sec, as the voltage across the load is made 1 p.u the load draws the required amount of current. As there is increment in voltage at 0.2 sec, there is increase in value of current. At 0.3 sec, the statcom is made to connect to load makes the load to draw the required amount of current.

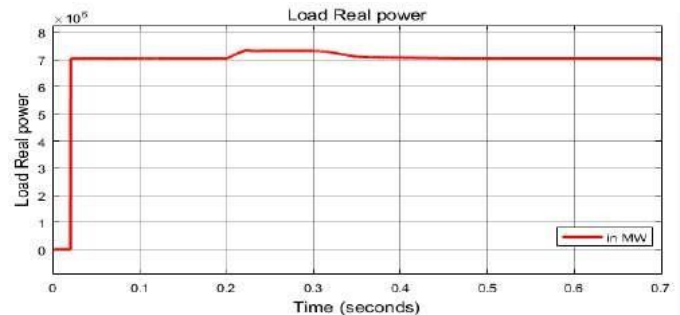

Fig -7.3.3-Load Real Power

It is observed from the wave form that at $t=0$ sec, the load is drawing its required power. After 0.2 sec there is increase in power due to increment in voltage, the statcom connected at 0.3 sec makes the load to draw the desired real power.

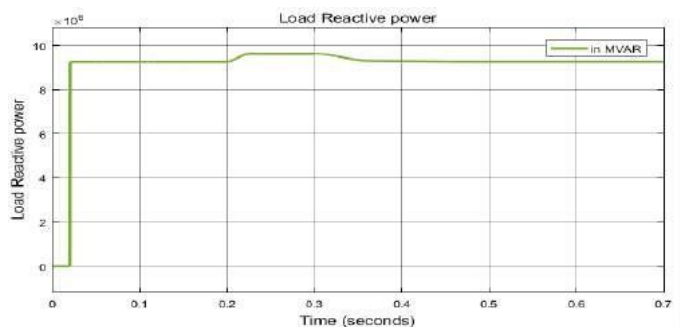

Fig -7.3.4-Load Reactive Power

It is observed from the wave form that at $t=0$ sec, the load is drawing its required power. After 0.2 sec there is increment in power due to increase in voltage, the statcom connected at 0.3 sec makes the load to draw the desired reactive power.

From the waveforms of the Figure 7 it is observed that the statcom is able to compensate both the active and reactive power by acting statcom as in the inductive nature by absorbing both active and reactive power from the supply to maintain the constant voltage across the load.

4. 2 When under RC Load

A RC load of 100 MVA consisting of 70MW of resistive load and 52.5 MVAR of capacitive load is considered to be as a load. The STATCOM operation at load side for different conditions such as decrease in voltage i.e., voltage sag and increase in the voltage i.e., voltage swell are to be tested.

4. 2. 1 Voltage Sag

As there will be variations in the voltage of the transmission system it is simulated in the Simulink by using programmable voltage source, where it is programmed to it voltage from 1 p.u voltage to 0.98 p.u voltage results in the voltage sag at time of 0.3 seconds. The decreased in the voltage can be observed from the power waveforms of the Source. The statcom is connected to the transmission system at the 0.5 seconds to increase the voltage at load to 0.98 p.u from the 1 p.u by the proper action taken by statcom.

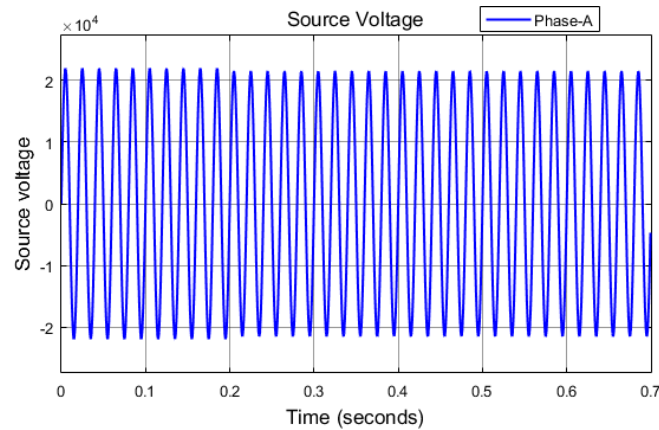

Fig -8.1.1-Source Voltage

At time t=0 sec, the voltage of the source is at 1 p.u. After 0.2 sec, the voltage is reduced from its 1 p.u to 0.98 p.u. it can be observed from the above waveform

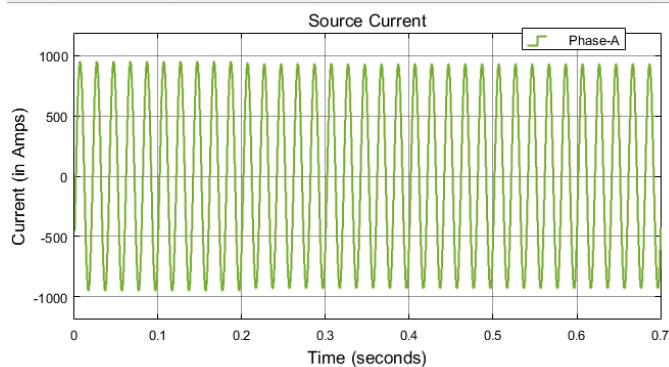

Fig -8.1.2-Source Current

At time t=0 sec, the current drawn from source is at normal value, at t=0.2 sec there is decrease in value due to decrease in voltage. After 0.3 sec, the statcom connection to the system made the system to draw less current than it requires.

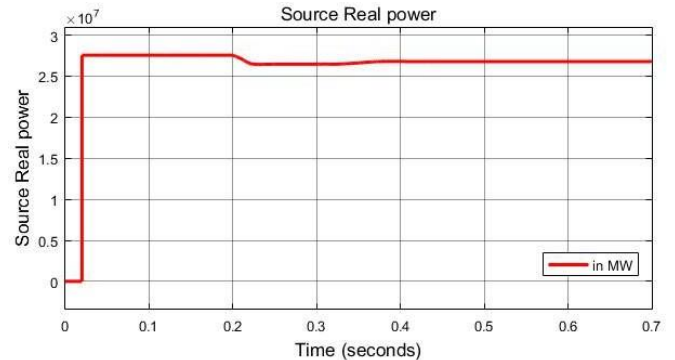

Fig -8.1.3-Source Real Power

At time t=0 sec, the real power drawn from the source is 27 MW after the connection statcom the real power drawn from the source is reduced to 26 MW.

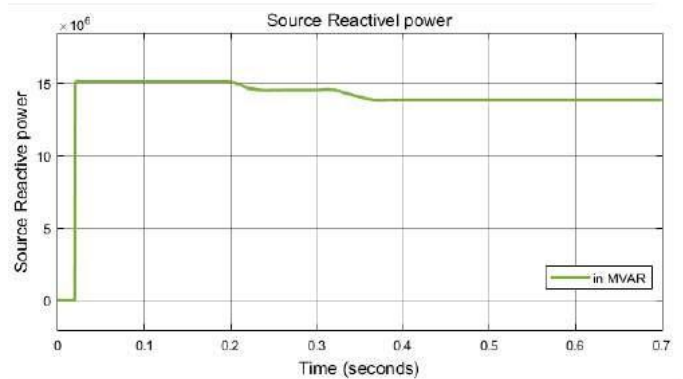

Fig -8.1.4-Source Reactive Power

At time t=0 sec, the reactive power drawn from the source is 15 MVAR, after connection of statcom at 0.3 sec the reactive power demand by the load is reduced by 2 MVAR.

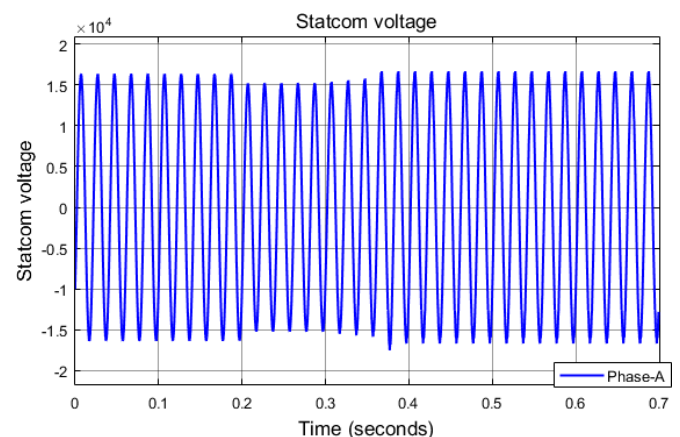

Fig -8.2.1-Statcom Voltage

At time $t=0$ sec, the statcom voltage is at value of 1 p.u. When time reaches 0.2 sec, there is decrease in the voltage to 0.98 p.u with the reduction of the voltage. At time $t=0.3$ sec, the statcom is made to connect and the voltage across the load is made to bring to the 1 p.u.

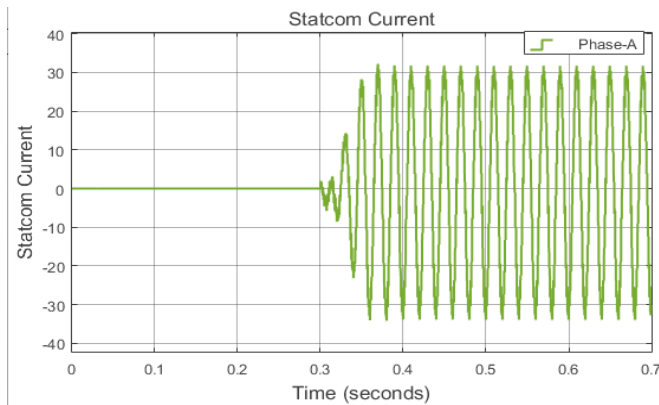

Fig -8.2.2-Statcom Current

At time $t=0$ sec, the power supplied by statcom is made to zero, when there is reduction voltage at load at $t=0.3$ sec the statcom makes the appropriate control action to supply required amount of power to load.

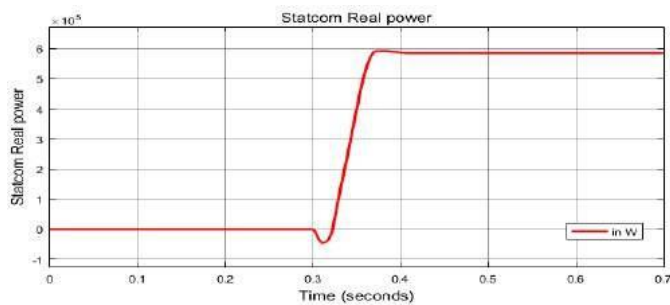

Fig -8.2.3-Statcom Real Power

At time $t=0$ sec, the statcom in closed position. After $t=0.3$ sec, the statcom is made to connect to the load to produce the required amount of real power demanded by the load to maintain it value normal to 1 p.u. The statcom supplies required amount of real power by leading the phase angle.

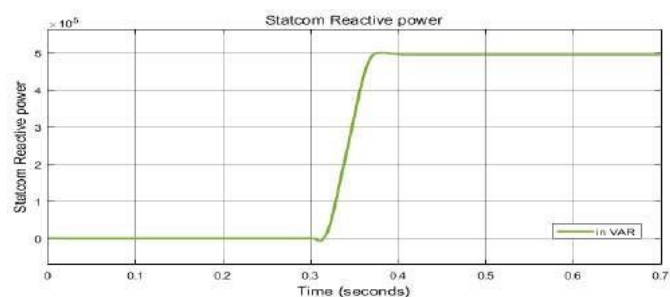

Fig -8.2.4-Statcom Reactive Power

At time $t=0$ sec, the statcom in closed position. After $t=0.3$ sec, the statcom is made to connect to the load to produce the required amount of reactive power demanded by the load to maintain it value normal to 1 p.u. The statcom supplies the

required amount of power by increasing the voltage across the dc capacitor.

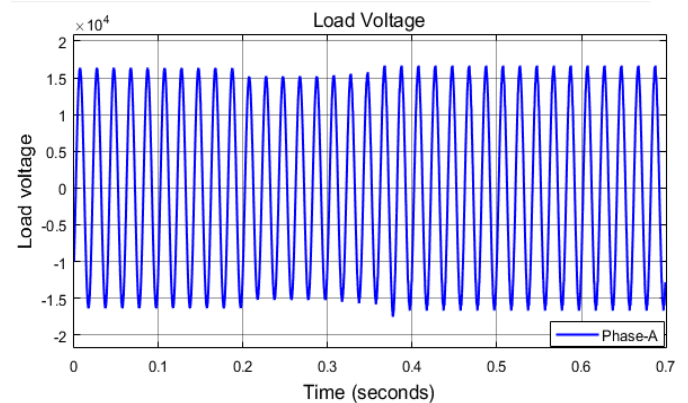

Fig -8.3.1-Load Voltage

Initially the voltage across the load is maintained at 1 p.u value, after 0.2 sec due to reduction in source voltage there is reduction in voltage value from 1 p.u to 0.98 p.u. At $t=0.3$ sec statcom is connected to bring back the voltage to 0.3 sec.

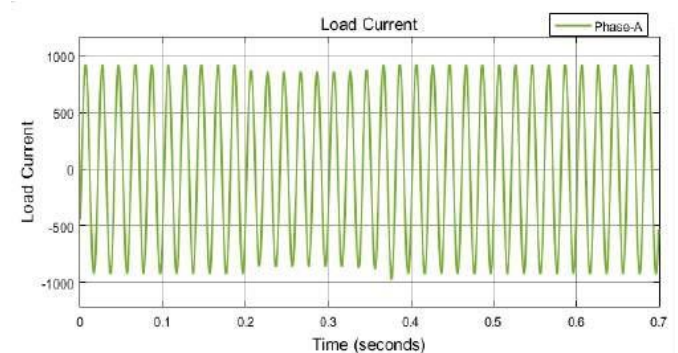

Fig -8.3.2-Load Current

At time $t=0$ sec, as the voltage across the load is made 1 p.u the load draws the required amount of current. As there is reduction in voltage at 0.2 sec, there is reduction in value of current. At 0.3 sec, the statcom is made to connect to load makes the load to draw the required amount of current.

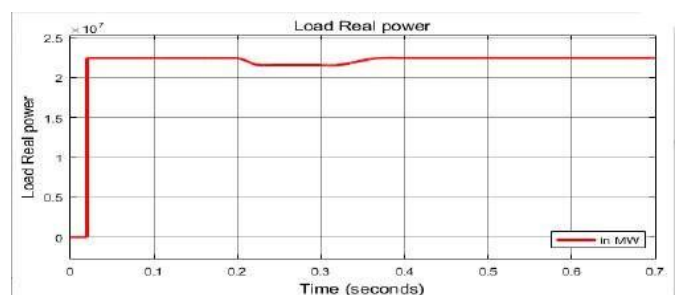

Fig -8.3.3-Load Real Power

It is observed from the wave form that at $t=0$ sec, the load is drawing its required power. After 0.2 sec there is decrease in power due to decrease in voltage, the statcom connected at 0.3 sec makes the load to draw the desired real power. Thus the power required by the load bring back to its normal.

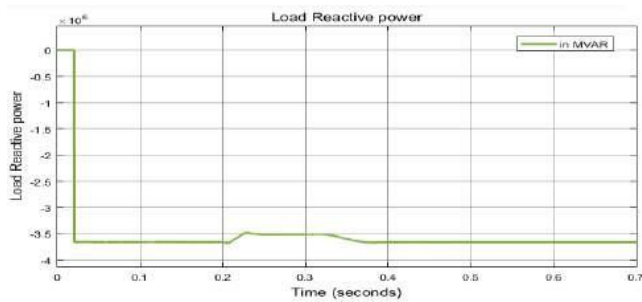

Fig -8.3.4-Load Reactive Power

It is observed from the wave form that at $t=0$ sec, the load is drawing its required power. After 0.2 sec there is decrease in power due to decrease in voltage, the statcom connected at 0.3 sec makes the load to draw the desired reactive power.

From the waveforms of the Figure 8 it is observed that the statcom is able to compensate both the active and reactive power by acting statcom as in the capacitive nature supplying both active and reactive power from the supply.

4. 2. 2 Voltage Swell

As there will be variations in the voltage of the transmission system it is simulated in the Simulink by using programmable voltage source , where it is programmed to it voltage from 1 p.u voltage to 1.2 p.u voltage results in the voltage swell at time of 0.3 seconds. The increase in the voltage can be observed from the power waveforms of the Source. The statcom is connected to the transmission system at the 0.5 seconds to decrease the voltage at load to 1.2 p.u from the 1 p.u by the proper action taken by statcom.

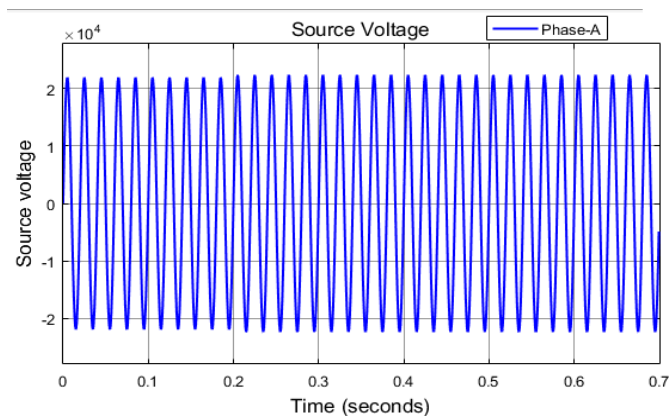

Fig -9.1.1-Source Voltage

At time $t=0$ sec, the voltage of the source is at 1 p.u. After 0.2 sec, the voltage is increased from its 1 p.u to 1.02 p.u. it can be observed from the above waveform. The statcom is made to connect at $t=0.3$ sec to reduce excess power drawn by the source.

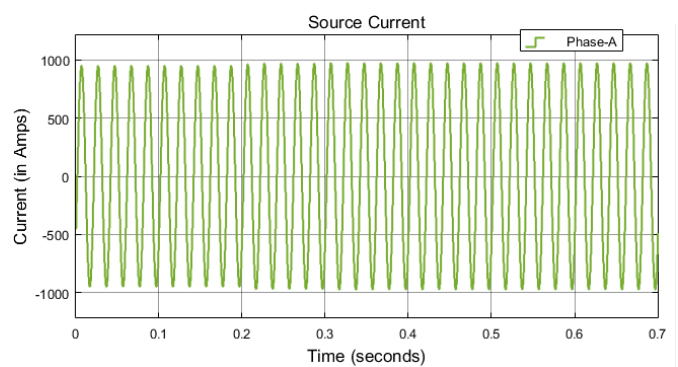

Fig -9.1.2-Source Current

At time $t=0$ sec, the current drawn from source is at normal value, at $t=0.2$ sec there is increase in value due to increase in voltage. After 0.3 sec, the statcom connection to the system made the system to draw more current than it requires to reduce the voltage across the load.

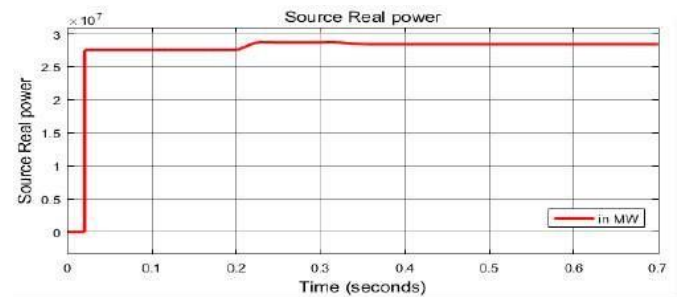

Fig -9.1.3-Source Real Power

At time $t=0$ sec, the real power drawn from the source is 27 MW after the connection statcom the real power drawn from the source is reduced to 29 MW. The excess power from the source after 0.3 seconds is absorbed by the statcom by reducing voltage across the dc capacitor.

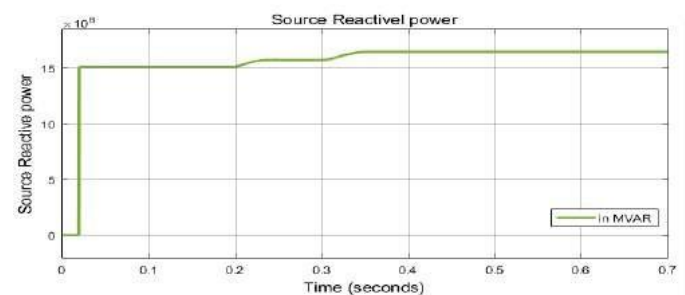

Fig -9.1.4-Source Reactive Power

At time $t=0$ sec, the reactive power drawn from the source is 15 MVAR, after connection of statcom at 0.3 sec the reactive power demand by the load is increased by 1 MVAR. The excess power from the source after 0.3 seconds is absorbed by the statcom by reducing voltage across the dc capacitor.

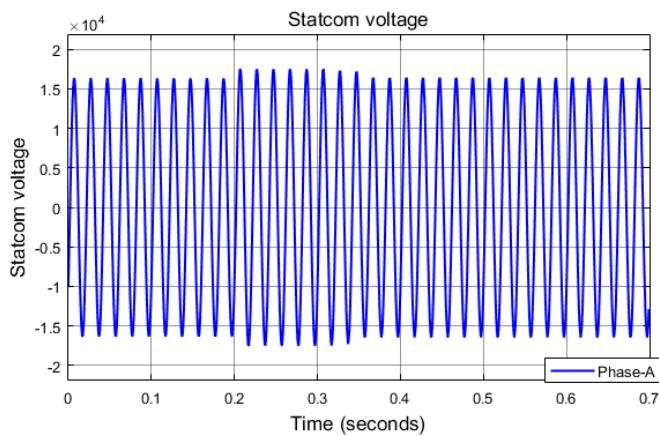

Fig -9.2.1-Statcom Voltage

At time $t=0$ sec, the statcom voltage is at value of 1 p.u. When time reaches 0.2 sec, there is increase in the voltage to 1.02 p.u. with the increase of the voltage. At time $t=0.3$ sec, the statcom is made to connect and the voltage across the load is made to bring to the 1 p.u.

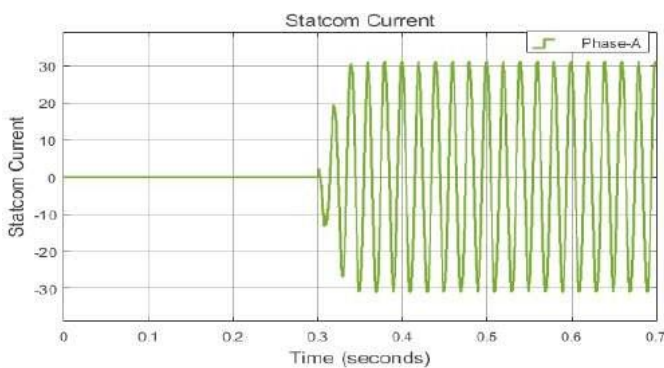

Fig -9.2.2-Statcom Current

At time $t=0$ sec, the power supplied by statcom is made to zero, when there is increment in voltage at load at $t=0.3$ sec the statcom makes the appropriate control action to absorb required amount of power to supply desired amount to load.

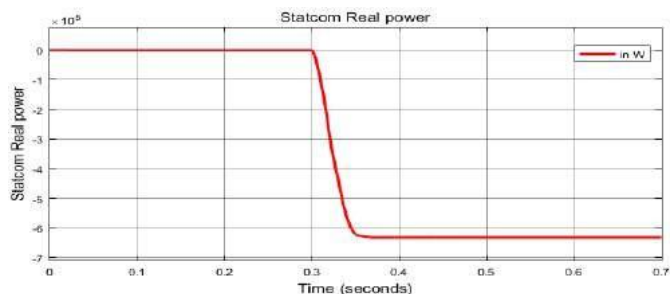

Fig -9.2.3-Statcom Real Power

At time $t=0$ sec, the statcom in closed position. After $t=0.3$ sec, the statcom is made to connect to the load to absorb the required amount of real power not demanded by the load to maintain its value normal to 1 p.u.

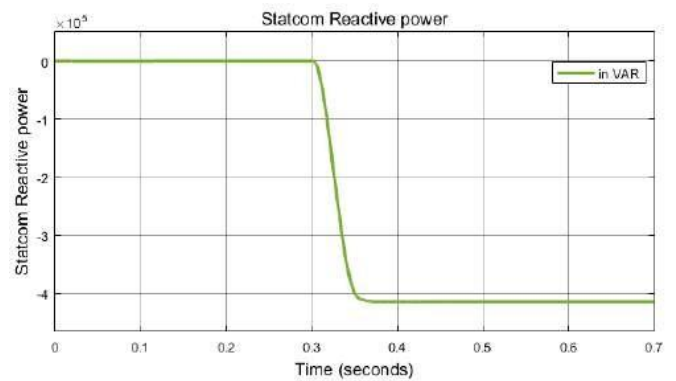

Fig -9.2.4-Statcom Reactive Power

At time $t=0$ sec, the statcom is in closed position. After $t=0.3$ sec, the statcom is made to connect to the load to absorb the required amount of reactive power not demanded by the load to maintain its value normal to 1 p.u.

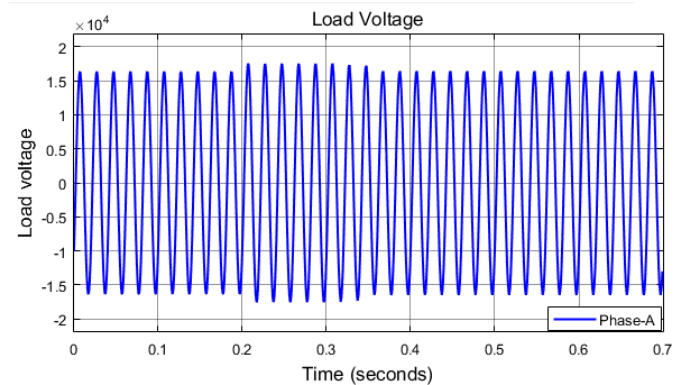

Fig -9.3.1-Load Voltage

Initially the voltage across the load is maintained at 1 p.u. value, after 0.2 sec due to increment in source voltage there is increase in voltage value from 1 p.u. to 1.02 p.u. At $t=0.3$ sec statcom is connected to bring back the voltage to 1 p.u.

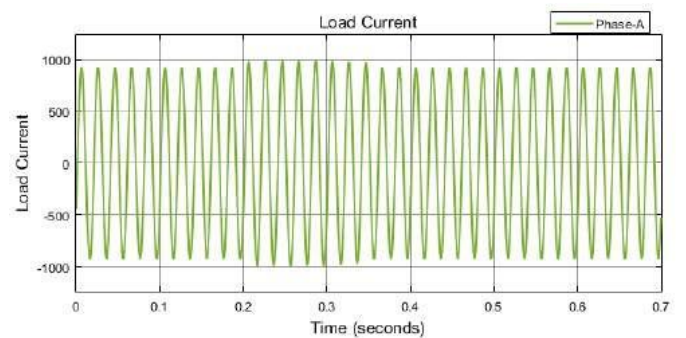

Fig -9.3.2-Load Current

At time $t=0$ sec, as the voltage across the load is made 1 p.u. the load draws the required amount of current. As there is increase in voltage at 0.2 sec, there is increase in value of current. At 0.3 sec, the statcom is made to connect to load makes the load to draw the required amount of current.

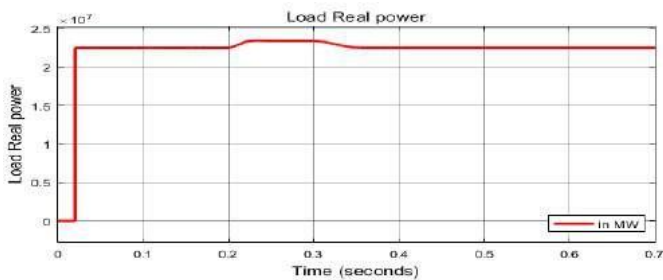

Fig -9.3.3-Load Real Power

It is observed from the wave form that at $t=0$ sec, the load is drawing its required power. After 0.2 sec there is increase in power due to increase in voltage, the statcom connected at 0.3 sec makes the load to draw the desired real power.

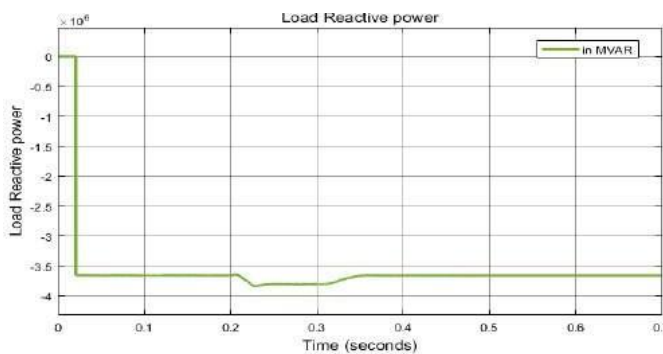

Fig -9.3.4-Load Reactive Power

It is observed from the wave form that at $t=0$ sec, the load is drawing its required power. After 0.2 sec there is increment in power due to increase in voltage, the statcom connected at 0.3 sec makes the load to draw the desired reactive power.

From the waveforms of the Figure 9 it is observed that the statcom is able to compensate both the active and reactive power by acting statcom as in the inductive nature by absorbing both active and reactive power from the supply to maintain the constant voltage across the load.

4. 3 When under R Load

A RC load of 100 MVA consisting of 70MW of resistive load is considered to be as a load. The STATCOM operation at load side for different conditions such as decrease in voltage i.e., voltage sag and increase in the voltage i.e., voltage swell are to be tested.

4. 3. 1 Voltage Sag

As there will be variations in the voltage of the transmission system it is simulated in the Simulink by using programmable voltage source, where it is programmed to it voltage from 1 p.u voltage to 0.98 p.u voltage results in the voltage sag at time of 0.3 seconds. The decreased in the voltage can be observed from the power waveforms of the Source. The statcom is connected to the transmission system at the 0.5 seconds to increase the voltage at load to 0.98 p.u from the 1 p.u by the proper action taken by statcom.

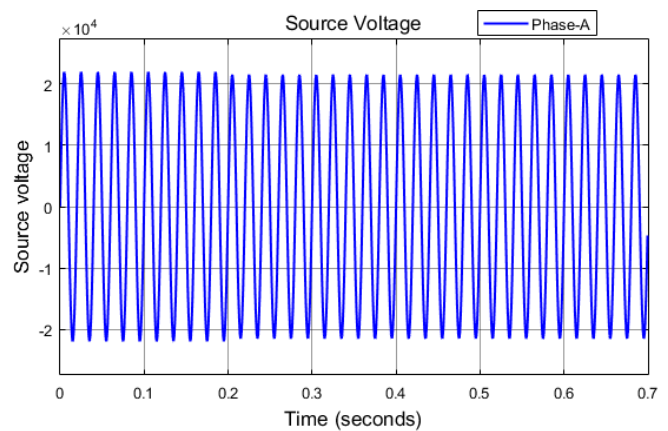

Fig -10.1.1-Source Voltage

At time $t=0$ sec, the voltage of the source is at 1 p.u. After 0.2 sec, the voltage is reduced from its 1 p.u to 0.98 p.u. it can be observed from the above waveform. The statcom is made to connect at $t=0.3$ seconds.

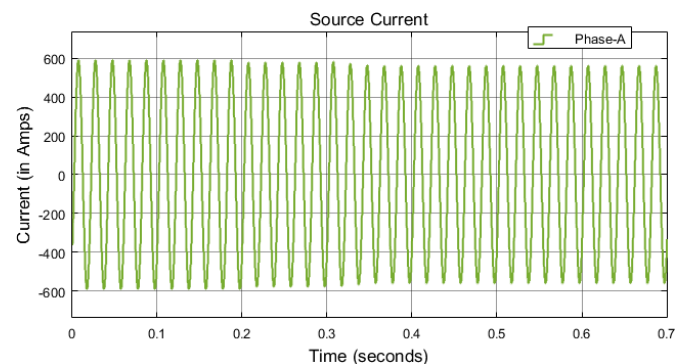

Fig -10.1.2-Source Current

At time $t=0$ sec, the current drawn from source is at normal value, at $t=0.2$ sec there is decrease in value due to decrease in voltage. After 0.3 sec, the statcom connection to the system made the system to draw less current than it requires.

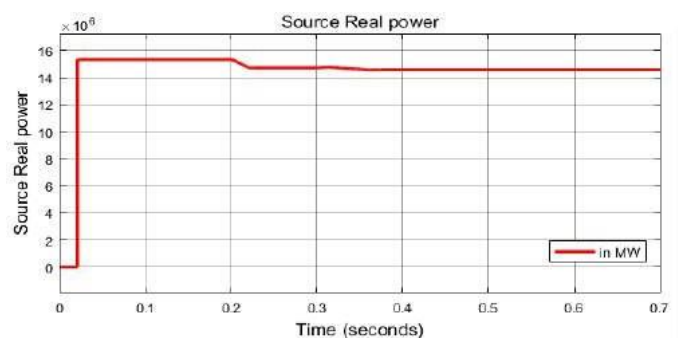

Fig -10.1.3-Source Real Power

At time $t=0$ sec, the real power drawn from the source is 15 MW after the connection statcom the real power drawn from the source is reduced to 14 MW. The real power demanded by the load is supplied by the statcom after time $t=0.3$ seconds.

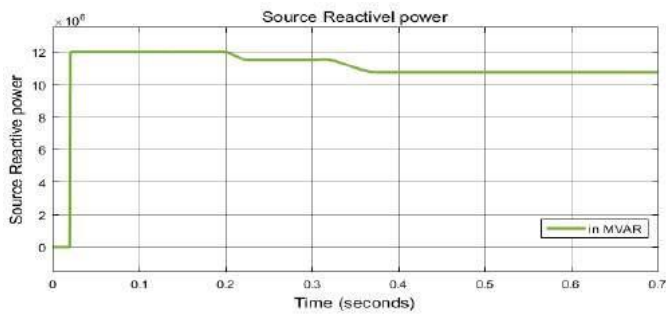

Fig -10.1.4-Source Reactive Power

At time t=0 sec, the reactive power drawn from the source is 12 MVAR, after connection of statcom at 0.3 sec the reactive power demand by the load is reduced by 11 MVAR. The reduction power supply is compensated by the statcom.

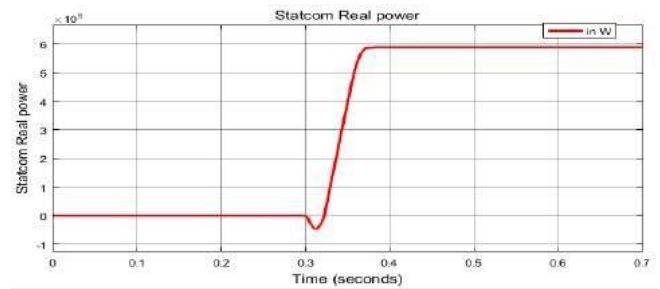

Fig -10.2.3-Statcom Real Power

At time t=0 sec, the statcom in closed position. After t=0.3 sec, the statcom is made to connect to the load to produce the required amount of real power demanded by the load to maintain it value normal to 1 p.u. The statcom delivers real power by increasing the voltage across the dc capacitor and by producing voltage waveform leading by an angle greater than the supply voltage.

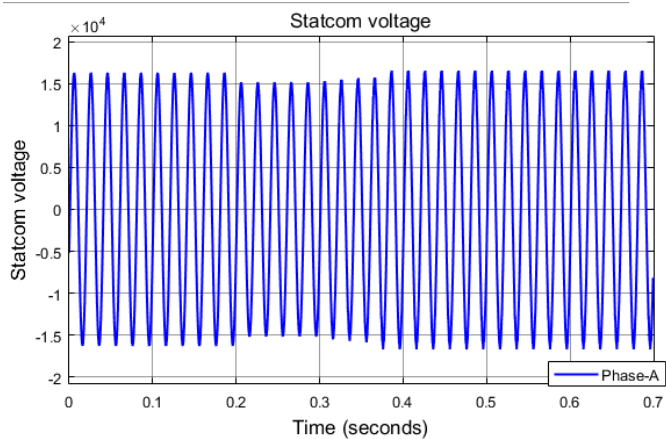

Fig -10.2.1-Statcom Voltage

At time t=0 sec, the statcom voltage is at value of 1 p.u. When time reaches 0.2 sec, there is decrease in the voltage to 0.98 p.u with the reduction of the voltage. At time t=0.3 sec, the statcom is made to connect and the voltage across the load is made to bring to the 1 p.u.

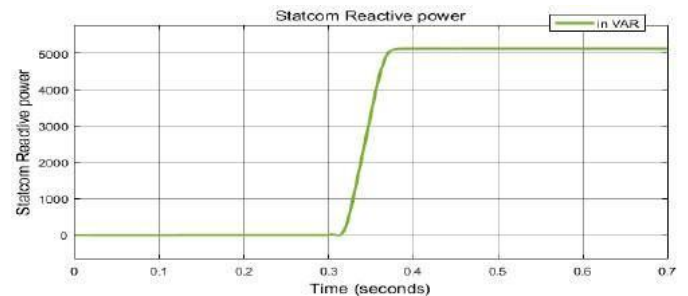

Fig -10.2.4-Statcom Reactive Power

At time t=0 sec, the statcom in closed position. After t=0.3 sec, the statcom is made to connect to the load to produce the required amount of reactive power demanded by the load to maintain it value normal to 1 p.u. The statcom produces reactive power by increasing the voltage across the dc capacitor.

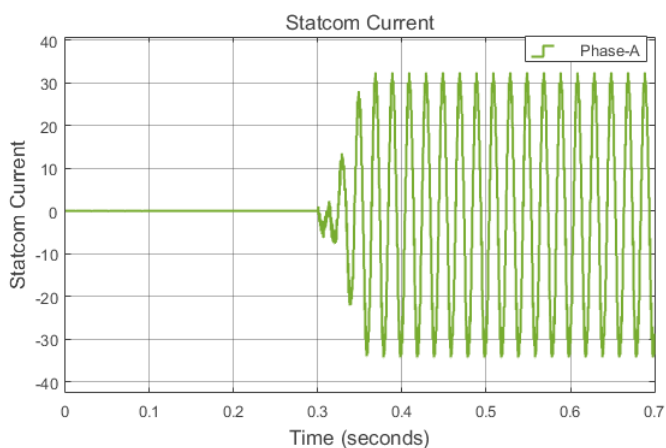

Fig -10.2.2-Statcom Current

At time t=0 sec, the power supplied by statcom is made to zero, when there is reduction voltage at load at t=0.3 sec the statcom makes the appropriate control action to supply required amount of power to load.

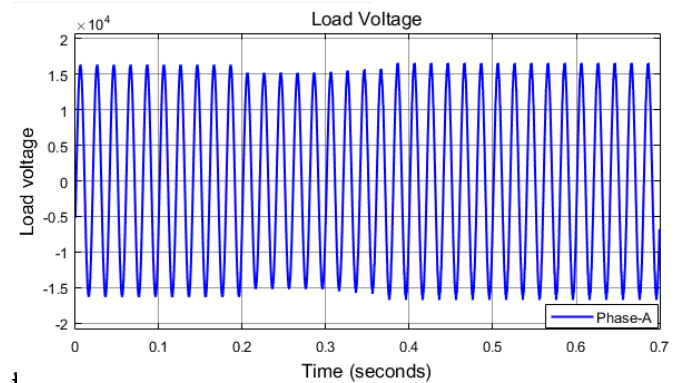

Fig -10.3.1-Load Voltage

Initially the voltage across the load is maintained at 1 p.u value, after 0.2 sec due to reduction in source voltage there is reduction in voltage value from 1 p.u to 0.98 p.u. At t=0.3 sec statcom is connected to bring back the voltage to 1 p.u. The

power supply by the statcom made the load voltage back to initial value which is 1 p.u.

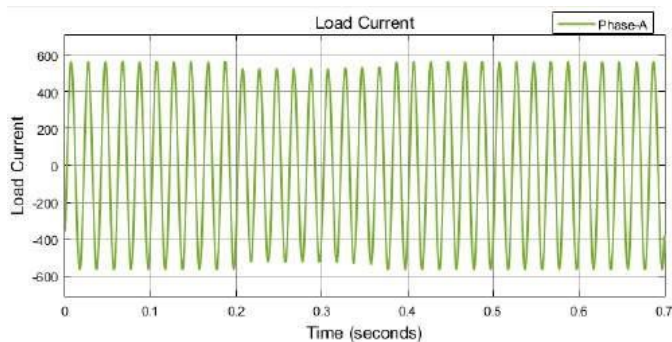

Fig -10.3.2-Load Current

At time t=0 sec, as the voltage across the load is made 1 p.u the load draws the required amount of current. As there is reduction in voltage at 0.2 sec, there is reduction in value of current. At 0.3 sec, the statcom is made to connect to load makes the load to draw the required amount of current.

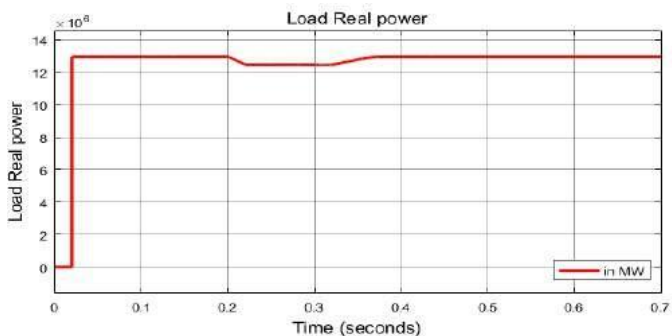

Fig -10.3.3-Load Real Power

It is observed from the wave form that at t=0 sec, the load is drawing its required power. After 0.2 sec there is decrease in power due to decrease in voltage, the statcom connected at 0.3 sec makes the load to draw the desired real power.

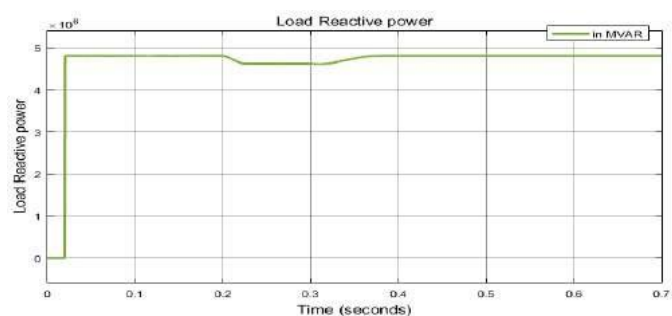

Fig -10.3.4-Load Reactive Power

It is observed from the wave form that at t=0 sec, the load is drawing its required power. After 0.2 sec there is decrease in power due to decrease in voltage, the statcom connected at 0.3 sec makes the load to draw the desired reactive power.

From the waveforms of the Figure 10 it is observed that the statcom is able to compensate both the active and

reactive power by acting statcom as in the capacitive nature supplying both active and reactive power from the supply.

4. 3. 2 Voltage Swell

As there will be variations in the voltage of the transmission system it is simulated in the Simulink by using programmable voltage source , where it is programmed to it voltage from 1 p.u voltage to 1.2 p.u voltage results in the voltage swell at time of 0.3 seconds. The increase in the voltage can be observed from the power waveforms of the Source. The statcom is connected to the transmission system at the 0.5 seconds to decrease the voltage at load to 1.2 p.u from the 1 p.u by the proper action taken by statcom.

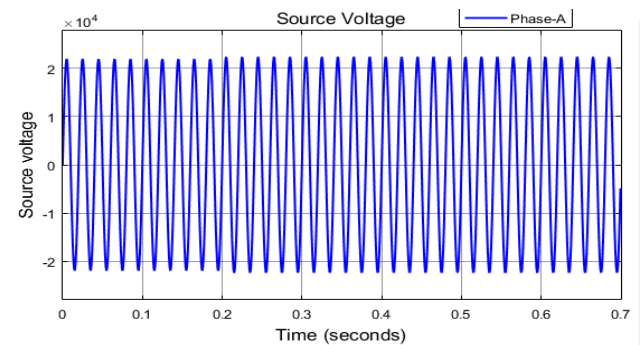

Fig -11.1.1-Source Voltage

At time t=0 sec, the voltage of the source is at 1 p.u. After 0.2 sec, the voltage is increases from its 1 p.u to 1.02 p.u. it can be observed from the above waveform. The statcom is made to connect to load at 0.3 seconds.

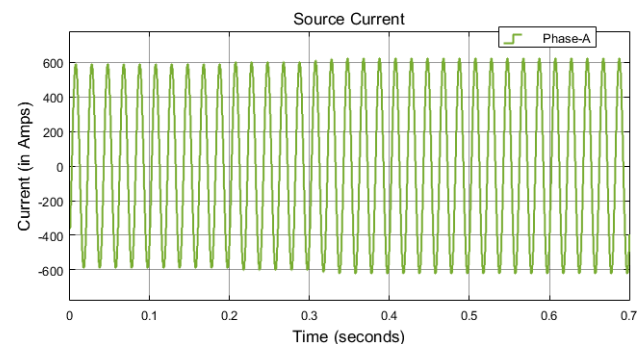

Fig -11.1.2-Source Current

At time t=0 sec, the current drawn from source is at normal value, at t=0.2 sec there is increase in value due to increase in voltage. After 0.3 sec, the statcom connection to the system made the system to draw more current than it requires to reduce the voltage across the load.

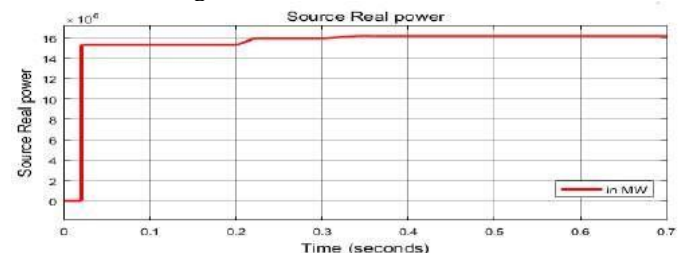

Fig -11.1.3-Source Real Power

At time $t=0$ sec, the real power drawn from the source is 15 MW after the connection statcom the real power drawn from the source is reduced to 16 MW.

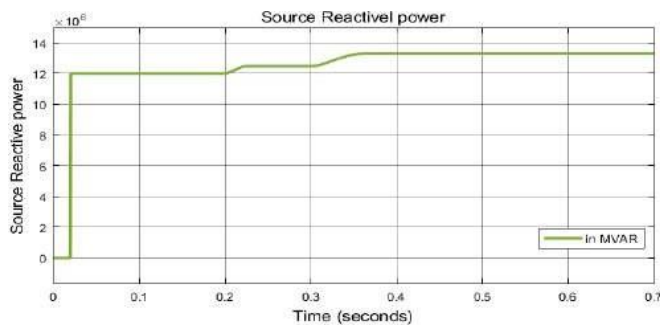

Fig -11.1.4-Source Reactive Power

At time $t=0$ sec, the reactive power drawn from the source is 15 MVAR, after connection of statcom at 0.3 sec the reactive power demand by the load is reduced by 1 MVAR.

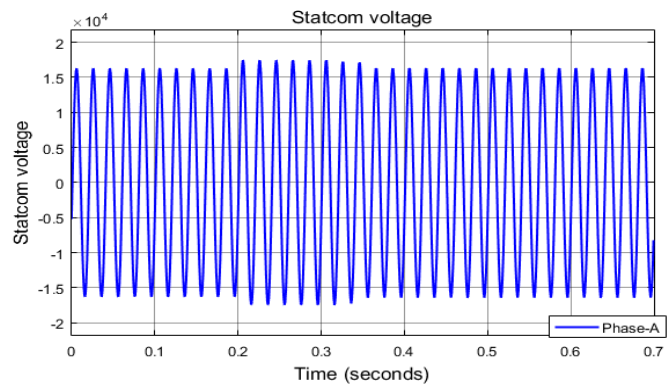

Fig -11.2.1-Statcom Voltage

At time $t=0$ sec, the statcom voltage is at value of 1 p.u. When time reaches 0.2 sec, there is increase in the voltage to 1.02 p.u. with the increase of the voltage. At time $t=0.3$ sec, the statcom is made to connect and the voltage across the load is made to bring to the 1 p.u.

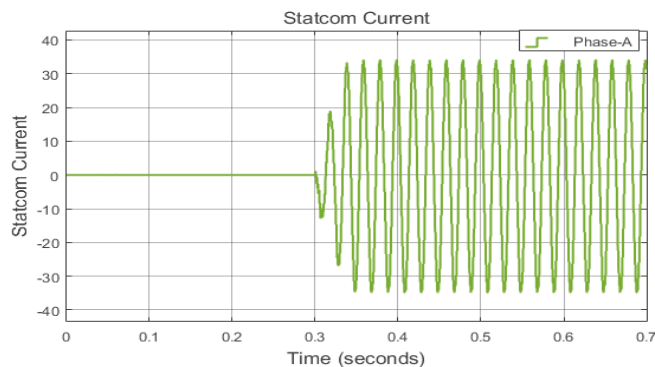

Fig -11.2.2-Statcom Current

At time $t=0$ sec, the power supplied by statcom is made to zero, when there is reduction voltage at load at $t=0.3$ sec the statcom makes the appropriate control action to absorb the required amount of power from the load.

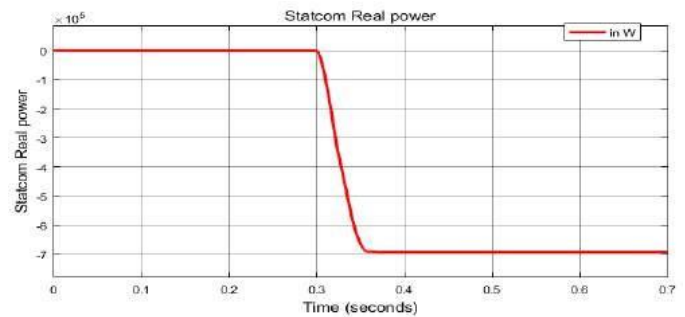

Fig -11.2.3-Statcom Real Power

At time $t=0$ sec, the statcom in closed position. After $t=0.3$ sec, the statcom is made to connect to the load to absorb the required amount of real power not demanded by the load to maintain it value normal to 1 p.u. it is made by reducing the voltage across the capacitor voltage.

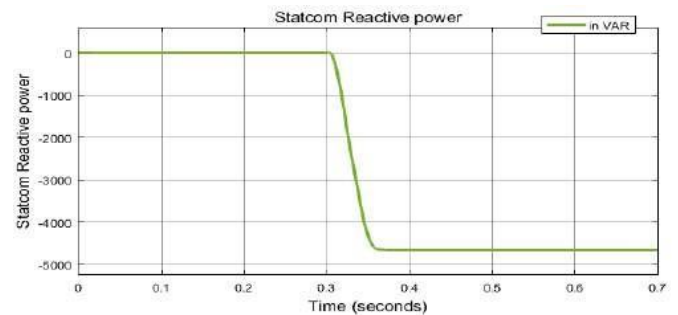

Fig -11.2.4-Statcom Reactive Power

At time $t=0$ sec, the statcom in closed position. After $t=0.3$ sec, the statcom is made to connect to the load to absorb the required amount of reactive power not demanded by the load to maintain it value normal to 1 p.u. it is made by reducing the voltage across the capacitor voltage.

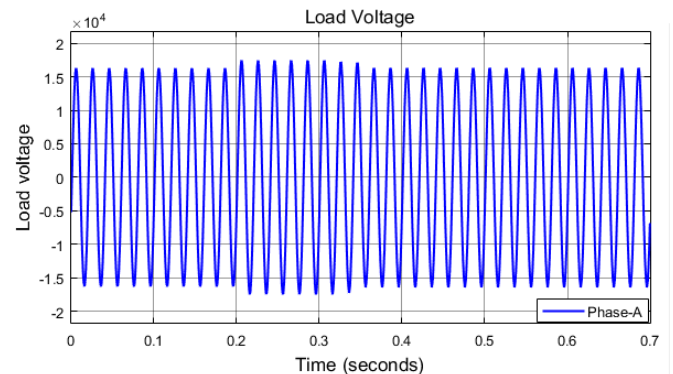

Fig -11.3.1-Load Voltage

Initially the voltage across the load is maintained at 1 p.u. value, after 0.2 sec due to reduction in source voltage there is reduction in voltage value from 1 p.u. to 1.02 p.u. At $t=0.3$ sec statcom is connected to bring back the voltage to 0.3 sec. The statcom reduces the voltage across the dc capacitor to absorb the power from the source caused due to increase in the source voltage.

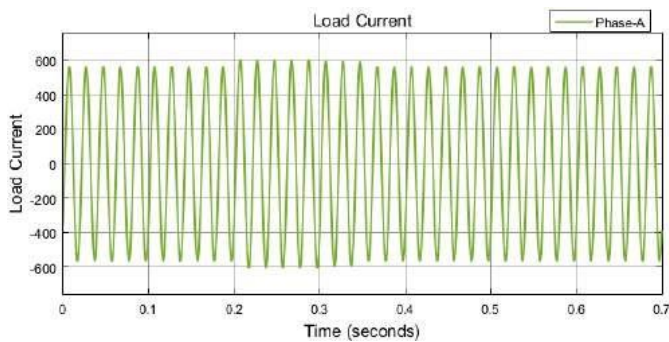

Fig -11.3.2-Load Current

At time $t=0$ sec, as the voltage across the load is made 1 p.u the load draws the required amount of current. As there is increase in voltage at 0.2 sec, there is increase in value of current. At 0.3 sec, the statcom is made to connect to load makes the load to draw the required amount of current.

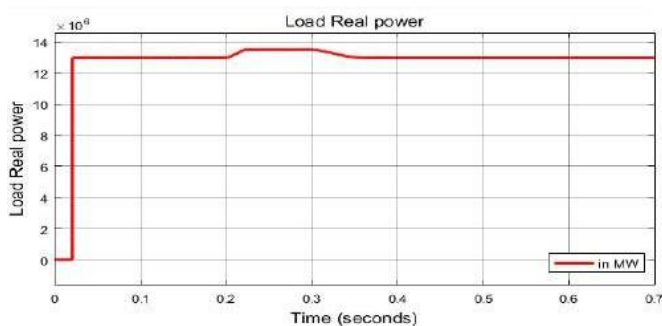

Fig -11.3.3-Load Real Power

It is observed from the wave form that at $t=0$ sec, the load is drawing its required power. After 0.2 sec there is increase in power due to increment in voltage, the statcom connected at 0.3 sec makes the load to draw the desired real power.

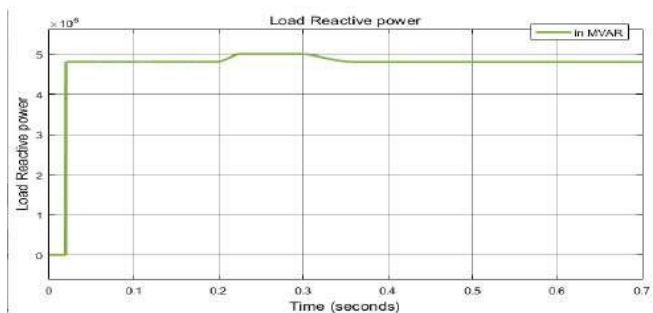

Fig -11.3.3-Load Reactive Power

It is observed from the wave form that at $t=0$ sec, the load is drawing its required power. After 0.2 sec there is increase in power due to increase in voltage, the statcom connected at 0.3 sec makes the load to draw the desired reactive power.

From the waveforms of the Figure 11 it is observed that the statcom is able to compensate both active and reactive power inductive nature by absorbing both active and reactive power from the supply to maintain the constant voltage across the load.

5. CONCLUSION

In the proposed control strategy the D-Q axis control is used to generate the gate pulses for the Diode clamped multilevel inverter. The statcom is tested for the different test conditions such as increase in the voltage i.e., voltage swell which is from 1 p.u to 1.02 p.u and decrease in the voltage i.e., voltage sag which is from 1 p.u to 0.98 p.u. The results of MATLAB/SIMULINK waveforms shows the STATCOM with the integration of multilevel topology is able to take appropriate action to bring the voltage to the normal and to supply both real and reactive power with the less harmonic content in the output waveforms.

REFERENCES

- [1] Bindeshwar Singh, K.S. Verma, Deependra Singh, C.N. Singh, Archana Singh, Ekta Agarwal, Rahul Dixit, Baljiv Tyagi, "Introduction of FACTS controllers, a critical review", International Journal of reviews in computing, Vol. 8, 31st December 2011
- [2] Meenakshi Rastogi, Abdul Hamid Bhat and Aijaz Ahmad," Simultaneous active and reactive power compensation using STATCOM", Vol. 4, No. 4, 2018
- [3] Mudasir Hussain Sheikh1, Navdeep Kaur Brar2," POWER QUALITY IMPROVEMENT IN DISTRIBUTION POWER SYSTEM USING STATCOM", Volume: 07 Issue: 02 , 2020, IRJET.
- [4] Mrs. Manisha patel, Divyesh S. Patel; Monty J. Chapadiya; Kevin K. Naik; Bhavik K.Patel," Reactive power compensation using STATCOM" Volume: 04, Issue: 04 2017, IRJET.
- [5] Pierre Giroux, Gilbert Sybille, Hoang Le-Huy, "Modeling and Simulation of a Distribution STATCOM using Simulink's Power System Blockset," IECON01: The 27th Annual Conference of the IEEE Industrial Electronics Society
- [6] N. G. Hingorani and L. Gyugyi, "Understanding FACTS Concepts and Technology of Flexible AC Transmission Systems," 1st Indian Edition, IEEE Press, New York and Standard Publishers Distributors, Delhi, 2000.
- [7] Reference book: "FACTS CONTROLLERS IN POWER TRANSMISSION AND DISTRIBUTION", K. R. Padiyar Department of Electrical Engineering Indian Institute of Science Bangalore-560 012 India.
- [8] Zhong Du; Tolbert, L.M.; Chiasson, J.N.; Ozpineci, B., "A cascade multilevel inverter using a single DC source," Applied Power Electronics Conference and Exposition, 2006. APEC '06. Twenty-First Annual IEEE, vol., no., pp.5 pp., 19-23 March 2006.
- [9] Pieree giourux; Hoangle Huayn, "Modelling and simulation of a distribution STATCOM using Simulink's Power System Block set", Conference: Industrial Electronics Society, 2001. IECON '01. The 27th Annual Conference of the IEEE, Volume 2