

# Smart Dustbin Using Node MCU

Chaitanya Landge<sup>1</sup>, Chinmayi Londhe<sup>2</sup>, Ketan Aggarwal<sup>3</sup>, Kshitij Shembalkar<sup>4</sup>, Rutvik Manchekar<sup>5</sup>, Professor. Nikita Khawase<sup>6</sup>

\*\*\*

**Abstract** - Urbanization in towns and cities has grown multifold in the past few decades, with this rapid growth, waste production has also increased and is not being managed properly. Dustbins are used everywhere and are a necessity. Dustbins are overflowing and spilling waste material on the streets till the municipal corporation acts. With this paper, we hope to eradicate overflowing dustbins and aim to build a prototype of an automatic waste management system that will open its lid automatically after detecting people who want to throw out their trash, detect when it is full, not open its lid when it is full and notify the respective authority. The dustbins will be provided with an ultrasonic sensor that will track the level of garbage inside the dustbin and notify an authority via the BLYNK application. The aim of this paper is also to promote more research into waste management issues through IoT Based waste management using smart dustbins.

**Key Words:** Automation, Node MCU, Green city, IoT, Smart City.

## 1. INTRODUCTION

Being the 2<sup>nd</sup> most populated and developing country, India faces unique problems that require unique solutions. Waste management in India is still being done through traditional means i.e., the municipal corporation collects and clears garbage periodically using garbage trucks manned by people. The collection of garbage is so uncertain in some regions that the dustbin overflows for a week or two which further proves to be an obstacle for the neighboring population. People have to manually open the dustbin, which further results in getting exposed to various harmful wastes. This may cause some skin irritations or diseases in a milder state. Skrappy-327 will be more effective and will reduce the exposure of municipal corporation personnel to toxic materials and garbage. If waste is not managed properly it can lead to mass production of bacteria, insects which can spread different kinds of diseases [1]. Skrappy-237 Will consist of a Node MCU microcontroller, an Ultrasonic Sensor, Infrared Sensor, and a servo motor. The project is cost-effective and provides a good solution to garbage handling.

## 2. METHODOLOGY

IOT Components that are used in this proposed system are shown in Table.1. Along with their purpose to build this smart dustbin.

**Table -1:** List of Components

Component Name	Purpose
Node MCU	Microcontroller board
Ultrasonic sensor	To detect objects in front of the dustbin and the level of trash in the bin
Trash bin	To collect waste
Power supply	Batteries to give power to the system
Servo Motor	To rotate the lid of the dustbin

## 2.1 Working of the Project

The system's brain, Node MCU, is linked to two ultrasonic sensors as well as the Blynk application. A single ultrasonic sensor is in charge of detecting the presence of an object at the dustbin's mouth. It calculates the object's distance and sends it to the MCU ESP8266. After calculating the object's distance, MCU instructs the servo motor on whether or not to rotate and open the lid. Another ultrasonic sensor measures the amount of waste in the trash can. It sends the reading to MCU, which analyzes the level and, if it exceeds the threshold value, notifies the user via the Blynk Application that the dustbin is full and that he should empty it as soon as possible. During this period, the MCU is constantly linked to the Blynk app, and the level of the dustbin is constantly displayed on the Blynk app interface.

## 2.2 Flowchart

In Fig.1, A flowchart depicting the logic of Object detection is shown. So, in the proposed system when input from the Ultrasonic sensor is measured and it turns out to be less than 10cm then the dustbin is kept closed and if the opposite happens then the lid of the dustbin is opened at 180 deg with help of a servo motor.

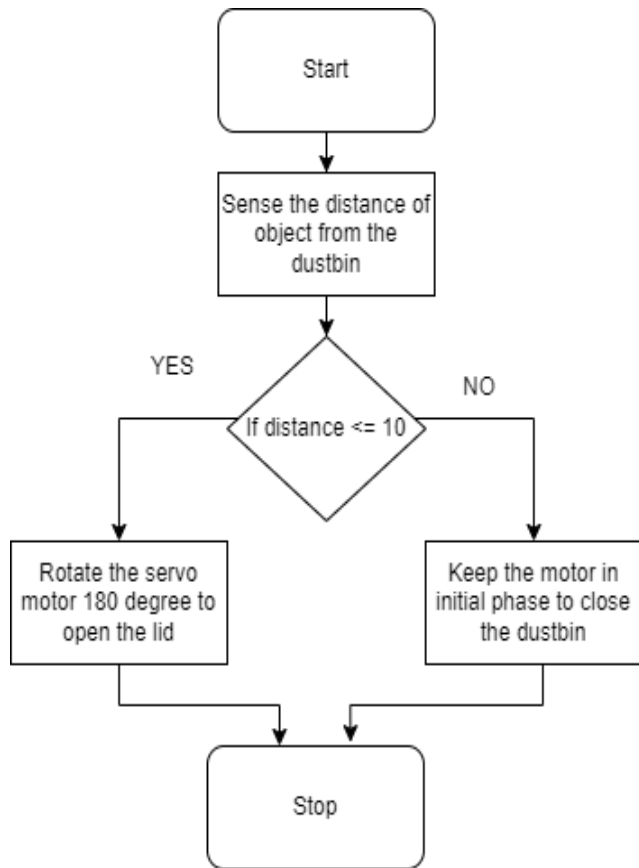

Fig.1. Flowchart for person detection

With the help of the Blynk application, the second element of our system is in charge of sending notifications to the user. The inner ultrasonic sensor detects the level of garbage and sends a notification to the user via the Blynk application using NodeMCU if it reaches the specified level.

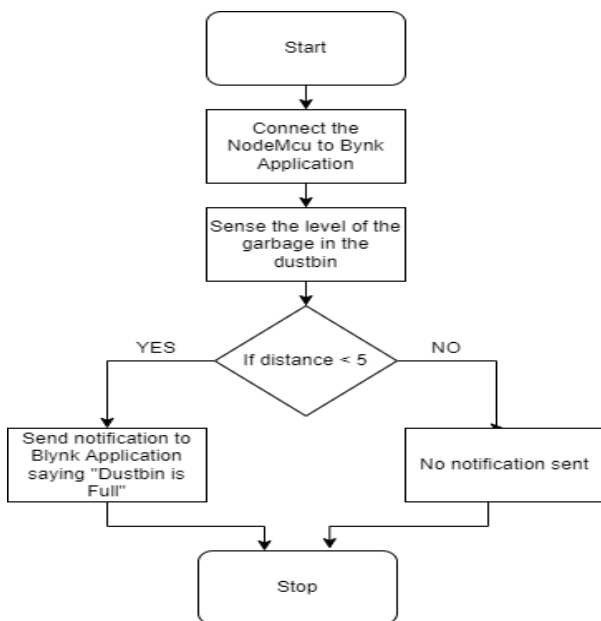
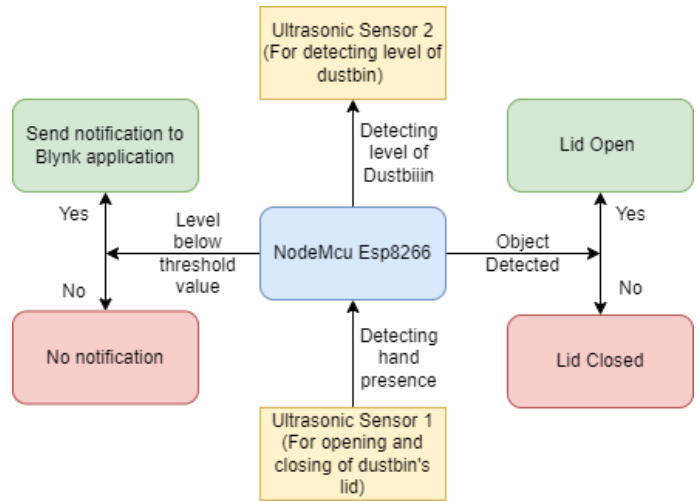

Fig 2. Flowchart for notification sending

### 2.3 Block Design



### 3. RESULTS AND DISCUSSIONS

The hardware prototype of the portable NodeMcu based Smart Dustbin with embedded sensors is shown in Fig.4 Microcontroller Node MCU is connected to an Ultrasonic sensor, servo motor to perform various activities.



Fig.4. Prototype of smart dustbin

In Fig.4. Connection of Node MCU to sensors is shown with the help of a breadboard.

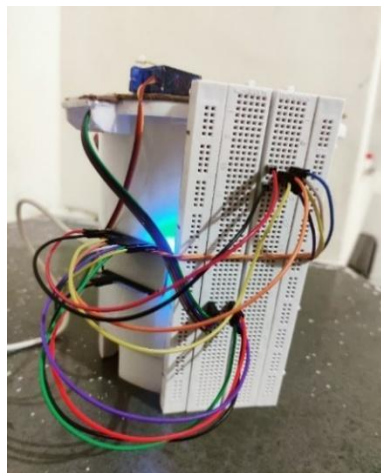

**Fig.5.** Connection through breadboard

In Fig.5. Connection of Node MCU to sensors is shown with the help of a breadboard.



**Fig.6.** Top View of dustbin when the lid opens

In Fig.6. The front view of the dustbin is shown where we can see an Ultrasonic sensor mounted on Dustbin.

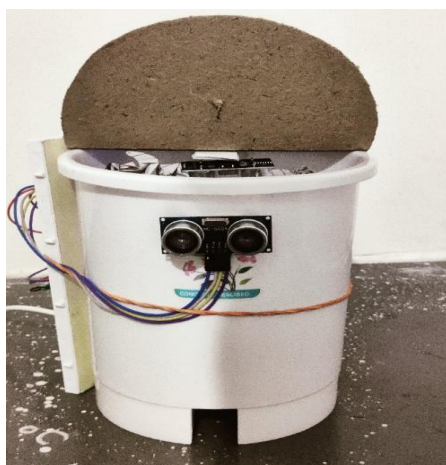

**Fig.7.** Front view of Dustbin when the lid is open

Finally, when the Dustbin is full with the garbage, the ultrasonic sensor placed in the dustbin would sense the level of garbage in the dustbin and then send a notification to the user or the personnel who is looking after this garbage collection.

The notification is sent to the user after the dustbin is full.

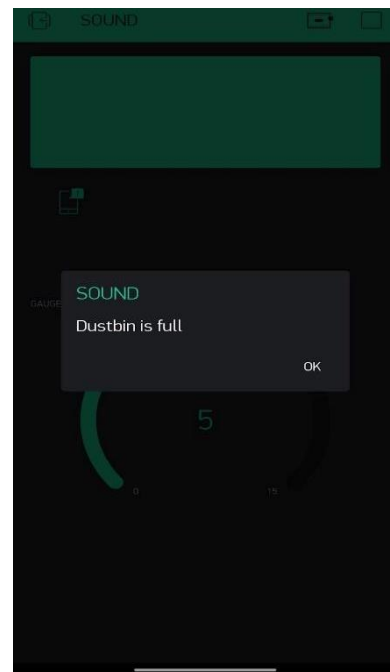

**Fig 7.** Image of the notification displayed to the user after the dustbin is filled

#### 4. LIMITATIONS

This proposed model can be limited if any of the malfunctions. As this model is based on an IoT network some errors in the network may result in undesirable/incorrect output. Because the ultrasonic sensor does not always detect the object (hand), opening the dustbins lid may take some time. The user will not receive a notification when the dustbin is full if the Blynk app is not connected to the Esp module. If the user fails to empty the trash can, the rubbish will remain stagnant, posing a health risk.

#### CONCLUSION AND FUTURE ENHANCEMENT

We give a thorough overview of the existing literature on smart waste bins, as well as current and future applications of smart waste management, in this study. Because of the accomplishments so far, other studies are being conducted to produce a smart waste bin. Nonetheless, it appears that there isn't one. There has been a significant deployment of this technology on a broad scale in the poorest countries of the world. The entire world A waste management system necessitates a custom-made solution that is cost-effective. There have been numerous interesting advancements in smart trash management in recent years. In previous years, indicating

a bright future. The Smart Grid is in desperate need of deployment. technology on a wide scale in impoverished countries around the world for a healthy and sustainable future.

The proposed model can be used with a line following robot and work in coordination with the dustbin so that a mobile dustbin could be built which could go places and using GSM module location of the dustbin could be sent to government personnel to track them and further improve its accessibility.

#### ACKNOWLEDGEMENT

The completion of a report for the project on "Smart Dustbin", has given all of us immense pleasure and knowledge. The authors wish to express their extreme gratitude to Nikita Khawase for her continuous assistance and guidance throughout the whole project.

#### REFERENCES

1. C. Kolhatkar, B. Joshi, P. Choudhari and D. Bhuvu, "Smart E-dustbin," 2018 International Conference on Smart City and Emerging Technology (ICSCET), 2018, pp. 1-3, DOI: 10.1109/ICSCET.2018.8537245.
2. P. S. N. Reddy, R. N. Naik, A. A. Kumar, and S. N. Kishor, "Wireless dust bin monitoring and alert system using Arduino," 2017 Second International Conference on Electrical, Computer and Communication Technologies (ICECCT), 2017, pp. 1-5, DOI: 10.1109/ICECCT.2017.8117960.
3. Parashar, Shikha & Tomar, Pankaj. (2018). Waste Management by a Robot- A Smart and Autonomous Technique. Journal of Electronics and Communication Engineering. 13. 31-36. 10.9790/2834-1303023136.
4. Fitzwatler G. Ang<sup>1</sup>, Maria Karla Angel R. Gabriel<sup>2</sup>, Jameson Sy<sup>3</sup>, Jenny Jane O. Tan<sup>4</sup> and Alexander C. Abad<sup>5</sup> Department of Electronics and Communications Engineering De La Salle University, Manila 2401 Taft Ave., Malate, Manila 1004, Philippines
5. Uralgunta, Nagaraju. (2017). SMART DUSTBIN FOR ECONOMIC GROWTH.
6. Amit Sinha, Kanika Gupta, Aatif Jamshed, Rajnesh Kumar Singh, Intelligent dustbin: A strategic plan for smart cities.

#### BIOGRAPHIES



**Chaitanya Yashwant Landge**  
Student at Vishwakarma Institute of Technology, Pune



**Kshitij Prafulla Shembalkar**  
Student at Vishwakarma Institute of Technology, Pune



**Rutvik Ravindra Manchekar**  
Student at Vishwakarma Institute of Technology, Pune



**Chinmayi Chaitanya Londhe**  
Student at Vishwakarma Institute of Technology, Pune



**Ketan Aggarwal**  
Student at Vishwakarma Institute of Technology, Pune