

REAR WHEEL ASSEMBLY IN A QUAD-BIKE: DESIGN AND ANALYSIS

Aman B. Sharma¹, Ronak R. Sarkar², Omkar R. Totre³, Gauravkumar V. Singh⁴, Ashish A. Jadhav⁵, Latika M. Rahate⁶

¹⁻⁶Student, Department of Mechanical Engineering, A.C Patil College of Engineering, Kharghar, Navi Mumbai, Maharashtra, India

Abstract- The document outlines the stages involved in designing the rear wheel assembly for an ATV constructed for the FMAE Quad Bike Design Competition. It provides a forum for undergraduate students to apply theoretical underpinnings to a real-world problem in the automotive industry. Simulation and optimization of the design are studied using iterative finite element analysis. Stress, strain, deformation, and thermal analysis were all used to examine the components. In order to reduce mass and expense, both knuckle and hub models were optimized to make them lighter and cheaper. Under the necessary boundary conditions, stress, total deformation, and associated strain were evaluated for each component. Assessing the suspension geometry parameters, identifying and evaluating the obstacles that were associated with paving a path towards the system's final assembly. The design parameters are determined based on judgements or the worst situation on the track, and the parameters are then simulated. Based on all of the simulations, we can conclude that the wheel assembly is safe, although it can be further refined based on the designer.

Key Words: Rear Wheel Assembly, Hub, Knuckle, Ball-Bearing, Brake, Disk Brake, Calliper, ATV, QUAD Bike, Lotus, SolidWorks 2020, Analysis, FEA, CNC Machining.

1. INTRODUCTION

One of the most important parts of any vehicle is the wheel assembly. This is due to the fact that the vehicle would not be able to move dynamically without it. In any vehicle, there are two sub-assemblies: the front and rear wheel assemblies. Each of these comprise of hub, knuckle, bearing, tyre, nut and bolts.

This document will solely cover the rear wheel assembly. Knuckle, hub, brake disk/caliper, taper roller bearing (taper roller bearing), nut and bolt, external retention ring (circlip), and tyre are all part of it. The primary benefit of this rear assembly design is mirroring, which implies that both left and right rear wheel assemblies are symmetrical of one another. This would be cost-effective because the pieces are interchangeable.

1.1. LOTUS ANALYSIS

Lotus Suspension Analysis (LSA) is a design and analysis technique that may be used for both the original layout of hard points on a vehicle

suspension as well as the design and angular orientation of suspension. To build and modify models, users must use a 3D-viewing environment, there is a way to "drag" hard points and bushes onto a computer screen, and the graphical and numerical results are updated in. Users may design their own suspension models using a template-based method to modelling, in addition to the 'standard' suspension templates offered.

Designers and analysts alike utilize LSA to plan the suspension hard point placements in order to obtain the desired kinematic behavior. Any number of outcomes (e.g., camber angle, toe angle) can be visually presented versus bump motion, roll motion, or steering motion. In real-time, these results are updated as the suspension hard points are shifted. The addition of compliant bushes to the kinematic model enables bush characteristics to be tuned in order to provide the appropriate compliant response for things such as lateral force steer.

In order to generate a rough wireframe of the rear assembly prototype, the following characteristics were specified for the rear wheel assembly.

- Rear suspension will be situated at the lower arm.
- We will be using single upper link.
- H-frame lower arm is equipped.
- Rear wheel wishbone setting: H-frame lower, single link upper

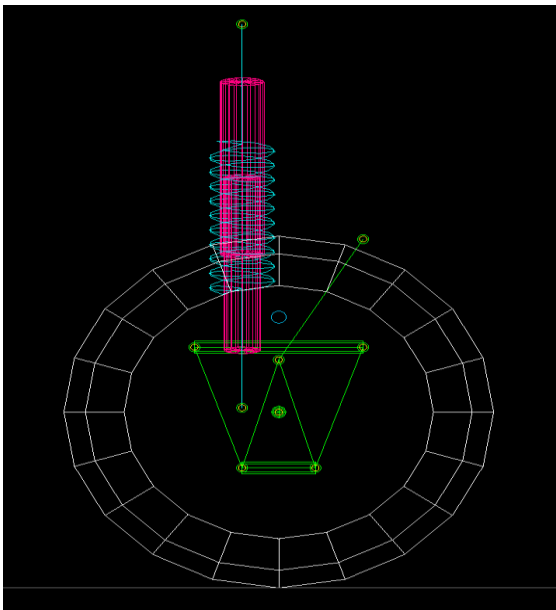

Fig 1.1: Lotus Suspension Right View

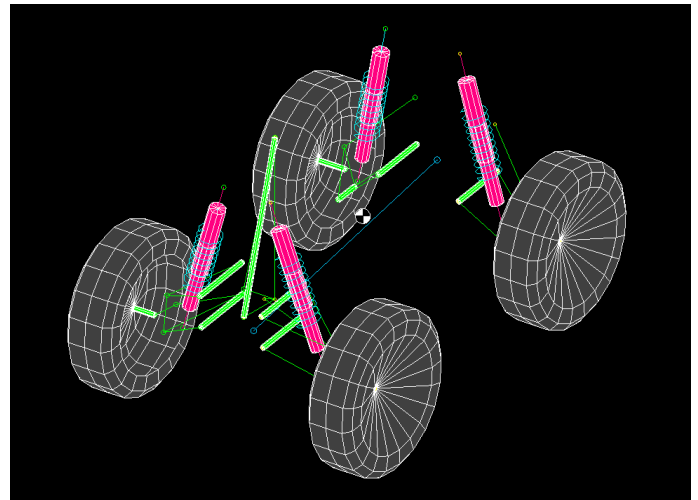

Fig 1.4: Lotus Suspension (Full ATV) Isometric View

1.2. PARAMETERS & GRAPHS

- Input parameters:

Wheel base distance from front to rear = 1092 mm

Center of Gravity (CG) = 461 mm

Rolling Radius = 293 mm

Tyre Width = 178 mm

Spring Radius = 12 mm

The inserted input values are shown in Figures 1.5 and 1.6.

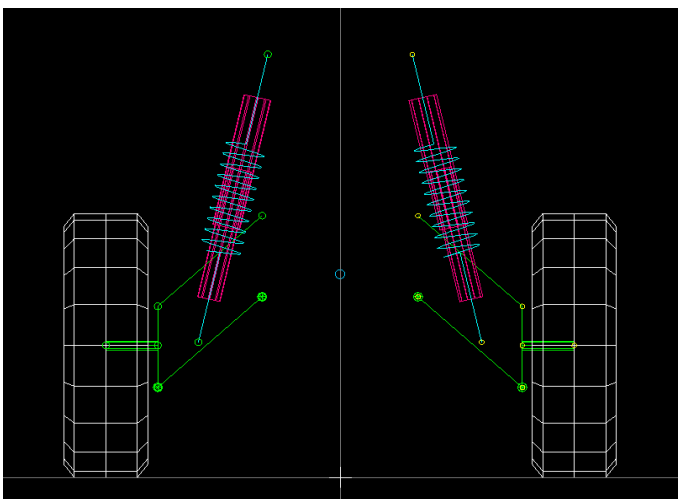

Fig 1.2: Lotus Suspension Front View

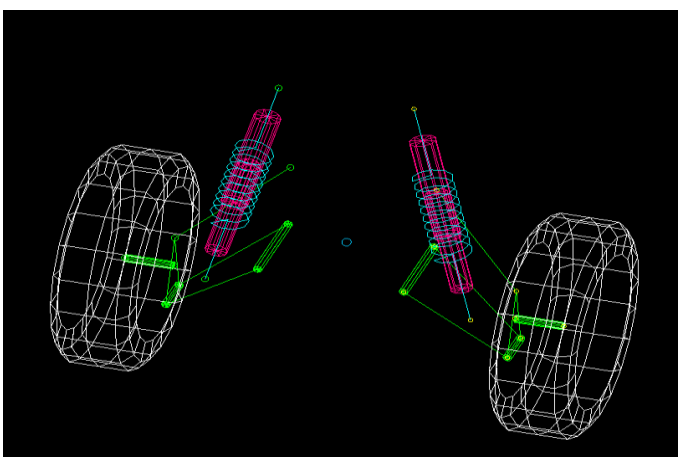

Fig 1.3: Lotus Suspension (Rear Wheel) Isometric View

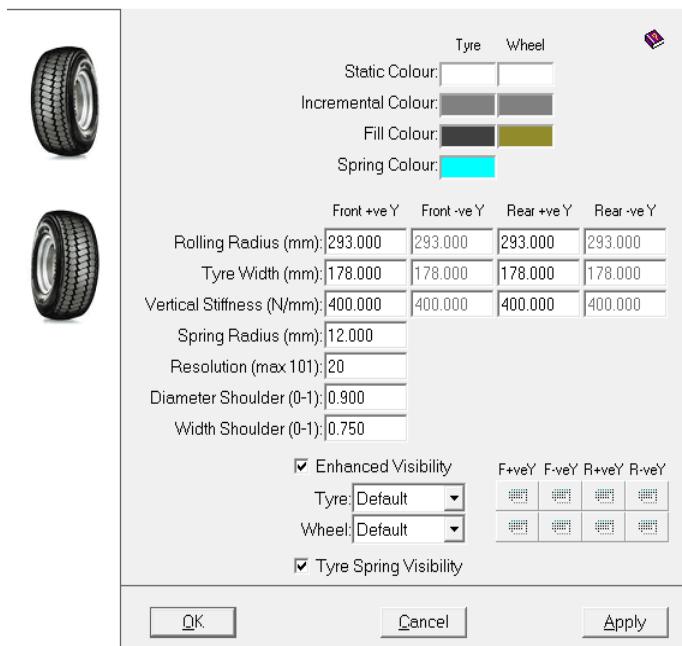

Fig 1.5: Lotus Software Tyre Parameters

	Edit Value
Bump Travel (mm)	60.000
Rebound Travel (mm)	-60.000
Bump Rebound Increment (mm)	20.000
Roll Angle (deg)	3.000
Roll Increment (deg)	0.500
Steer Travel (mm)	30.000
Steer Increment (mm)	5.000
Wheelbase (mm)	1092.000
C of G Height (mm)	461.000
Braking Front (%)	60.000
Drive Front (%)	0.000
Total Weight Front (%)	40.000
Front Brake Type (1 = Inboard 2 = Outboard)	2
Rear Brake Type (1 = Inboard 2 = Outboard)	2
Total Sprung Weight (kg)	0.0000
Front Type (1 = Independent 2 = Rigid)	1
Rear Type (1 = Independent 2 = Rigid)	1
Drive Shaft Joint (Tulip) Radius (mm)	65.0000
No of Bump Increments	5
No of Rebound Increments	5
No of Roll Increments	5
No of Steer Increments	5

Fig 1.6: Lotus Software Parameters

- Output values (Rear Wheel Assembly) shown in the graphs:

Camber Angle = -1 to +1 (0 degree)

Toe Angle = -1 to +1 (0 degree)

Castor Angle = -1 to +1 (0 degree)

Kingpin Angle = -1 to +1 (0 degree)

The output values (both front and rear wheel assembly) are shown in graph form in Figure 1.7 (Camber, castor, toe, and kingpin angle). Figure 1.8, on the other hand, shows the output values of the rear wheels.

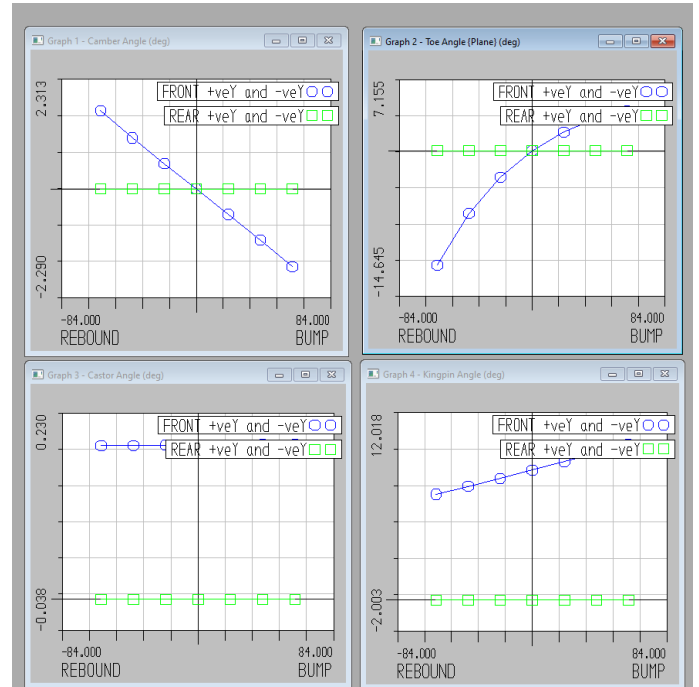

Fig 1.7: Lotus Software Output Graphs (Full ATV)

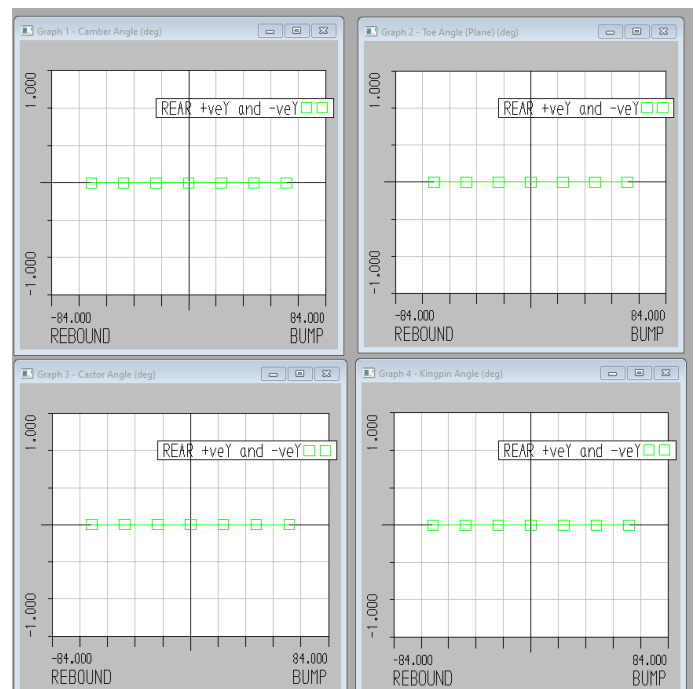

Fig 1.8: Lotus Software Output Graphs (Rear Wheel)

2. KNUCKLE

To further link the chassis and wheel assembly using A-arms, Knuckles are used. It integrates the suspension as well as brake components in order to stabilize the vehicle. Meanwhile, knuckle is fixed to the chassis, and it is only hub that turns the wheel around it. The final CAD model of Knuckle produced in SOLIDWORKS is depicted in Figures 2.1 and Figure 2.2. High strength, low weight, economy, and ease of manufacture were the four guiding principles in the design process for this product.

2.1. DESIGN

Designing is one of the most important parts of the process because any mistakes can be dangerous to the rider. Before producing any type of sketch, it is critical to understand the constraints connected with those components. In designing a successful knuckle, the following factors were taken into consideration:

1. Suspension Hard points:

The location of Suspension points was calculated with the help of LOTUS Suspension Analysis software.

2. Wishbone mountings:

Once the hard points are known, wishbone mounting is started.

3. Bearing spacing:

The bore dimension is selected based on the outer diameter of the bearing. A step of 4 mm is created in order to restrict the bearing from slipping out of the assembly.

4. Thickness:

Total thickness of the knuckle is based on the step created and the bearing thickness.

2.2. MATERIAL SELECTION

The next critical phase in hub manufacturing is material selection. Because it will assist us in accomplishing our aim of increase strength while reducing body weight.

Property	Al7075	EN 24
1. Young's Modulus (GPa)	71.7	210
2. Density (kg/m ³)	2810	7840

3. Poisson's ratio	0.33	0.294
4. Tensile Strength (MPa)	572	900

Based on the above parameters, EN 24 is selected.

2.3. ANALYSIS

We can begin analysis after the content has been repaired. Analysis aids in the discovery of surplus materials as well as weak points. Once the issues have been identified, we will proceed to the conceptual design stage, where the part will be updated and then analyzed once more.

2.4. MANUFACTURING

The final stage, after the analysis has been conducted and the component is safe to use, is to produce it. Both rear knuckles will be CNC machined.

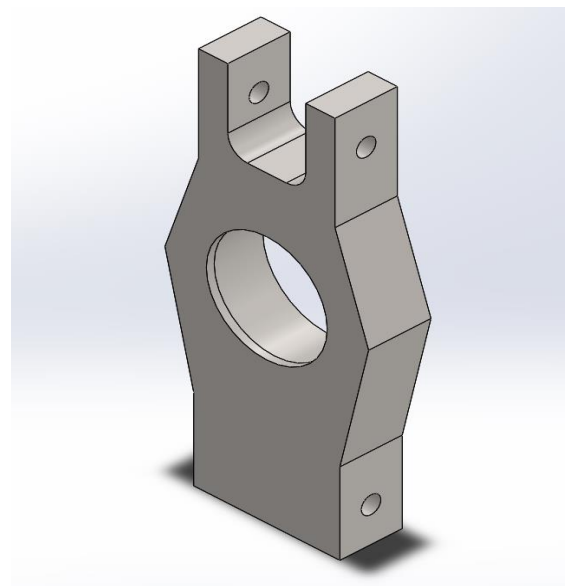

Fig 2.1: Knuckle Isometric View

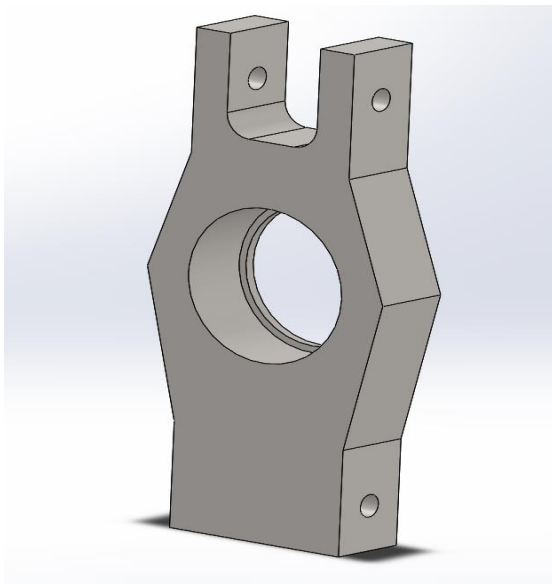

Fig 2.2: Knuckle Isometric View (From Back)

3. HUB

A wheel hub is an automobile component that is utilized in most vehicles, regardless of their weight carrying capacity, i.e. light and heavy cars. The hub serves as a rotary component in the wheel assembly, transmitting power from the axle and allowing the wheel to rotate. It is one of the most critical components of the assembly, so it necessitates high-quality, low-cost materials that can withstand any form of failure. In SOLIDWORKS, the completed CAD model of the Hub can be seen in Figure 3.1 and Figure 3.2. High strength, low weight, economy, and ease of manufacture were the four guiding principles in the design process for this product.

3.1. DESIGN

Designing is one of the most important steps of the procedure, as any mistake might be dangerous to the rider. The limits connected with such components must be understood before constructing any form of sketch. Listed below are the constraints that helped in creating a successful wheel hub:

1. Wheel lobe:

The base of the hub also known as wheel lobe is designed based on the PCD of rim of the tyre. This is due to the fact that the wheel hub sub-assembly has to be connected to the tyre in order to complete the entire assembly and facilitate motion. These are connected to each other with the help of nut and bolts

2. Disc lobe:

At an offset the disc lobe is designed, based on the disc plate. This is due to the simple fact that the disc plate is to be mounted on the disc lobe.

3. Bearing Provision:

For bearing to be rotated in one place only it is restricted by circlip (external retainer ring) on one end and by the hub on the other end.

4. Axle Provision:

There are splines created in the internal of the hub's cylindrical part.

5. Height:

The total height of the hub is fixed with the help of LOTUS software.

3.2. MATERIAL SELECTION

The hub is made of EN 24 as well, same like the knuckle.

3.3. ANALYSIS

Once the material is fixed, we can proceed with analysis. Analysis helps in finding the excess materials as well as the weak spots. Once we find the errors out we again move on to the designing stage where the part will be modified and then analyzed again.

3.4. MANUFACTURING

The final step to be done once analysis turns out to be safe is to manufacture the part. Both the rear hubs are CNC machined.

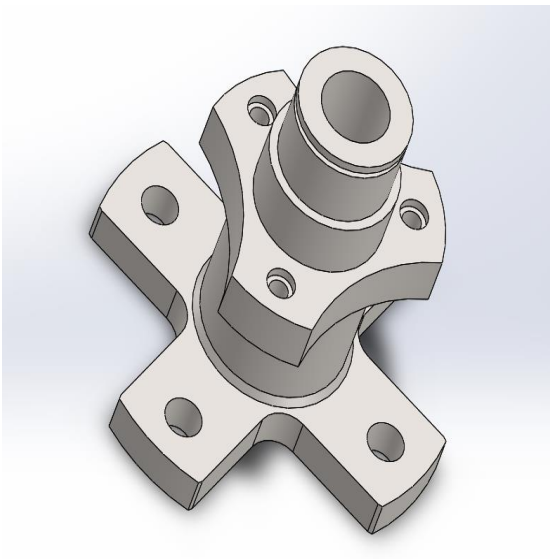

Fig 3.1: Hub Isometric View

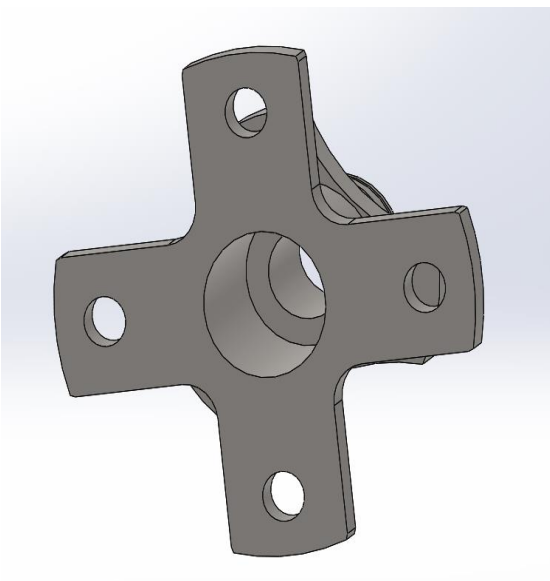

Fig 3.2: Hub (Bottom View)

- Help maintain constant speed down-hill/slope.
- Hold vehicle stationary on flat or on gradient.
- Work in diverse conditions like wet, slippery, rough and dry or on curves of a road as well as on variable rated of acceleration.
- Ease of manufacturability, performance and simplicity are a few important criteria considered

For selection of brakes:

We are using a brake system from Yamaha Ray ZR. The disc and caliper are used for both the front and rear wheels. The front and rear brake systems are separate and can trigger the rear two tyres independently.

4.1. BRAKE DISK

Brand: NIKAVI DBP17

Material: Stainless Steel

Disk size: Diameter = 170 mm

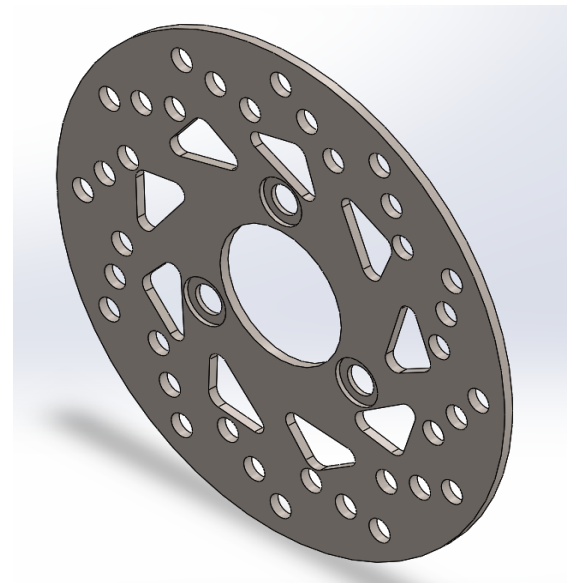

Fig 4.1.1: Brake Disk (CAD) Isometric View

4. BRAKE SYSTEM

A good brake system is very important for vehicle safety. There are two kinds of service brakes that are commonly used: disc brake and drum brake. Additionally, almost all vehicles comes with an emergency brakes and anti-lock brakes.

As per QBDC rule book, It is required that all new vehicles should have at least two independent hydraulic braking systems. This ensures that the system will provide adequate brake power in the event of failure. The main requirements of a braking system are:

- Decelerate in a controlled repeatable manner.



Fig 4.1.2: Original Brake Disk

4.2. BRAKE CALIPER

Brand: NIKAVI



Fig 4.2.1: Original NIKAVI Brake Caliper



Fig 4.2.2: Original NIKAVI Brake Caliper

(Front View)

5. BALL-BEARING

Numerous devices with rotational motion rely on rolling-element bearings to operate smoothly and efficiently, from vehicle wheels to motors and turbines to medical equipment. A ball bearing is a sort of rolling-element bearing that provides three major roles while facilitating motion: it bears weights, lowers friction, and positions moving machine elements.

To decrease surface contact and friction between moving planes, ball bearings employ balls to divide two "races," or bearing rings. When compared to flat surfaces rubbing against each other, rotating balls have a lower coefficient of friction. Ball bearings usually have a lower load capacity for their size than other rolling-element bearings because there is minimal surface contact between the balls and races.

We are employing tapered Ball bearings for this prototype. This bearing is utilized to reduce friction and heat produced by earlier bearing designs that led them to fail. Rolled loads are uniformly distributed because of the tapered profile. Transmission shafts and rotating axles benefit from this since it reduces wear and increases durability. Since these bearings are so durable, these shafts may operate for hundreds of thousands of kilometers without any maintenance. Because of their dependability, they can also perform a variety of heavy-duty activities.

Bearing type: TAPER ROLLER BEARING SKF-32008 X



Fig 5.1: Original SKF-32008 X



Fig 6.1: M6 (CAD) Isometric View

- IS 1364- M12 x 50 x 30 - S

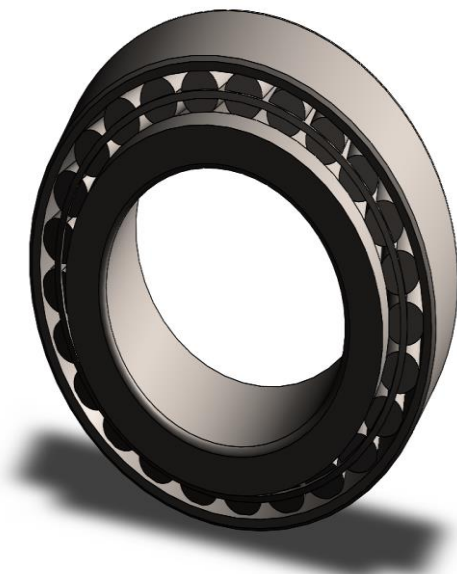

Fig 5.2: SKF-32008 X (CAD) Isometric View



Fig 6.2: M12 (CAD) Isometric View

6. BOLT

When it comes to this conceptual design, two types of fasteners: M6 and M12 are utilized, both of which meet the Indian standard. One of them is M6 bolts, which will be utilized to align the hub and brake disc. Furthermore, the M12 bolts will be inserted to secure the tyre to the hub.

Underneath is the pictorial representation of both the fasteners: (picture from SolidWorks 2020 toolbox)

- IS 2269- M6 x 16 - N

7. EXTERNAL RETAINER RING (CIRCLIP)

External retention rings are used to secure shaft casings to the outside of the shaft. These rings are intended to secure the shaft.

Type: Bowed Preloading Ring

Inner Diameter: 37.7mm

This retainer ring holds the bearing in place against the hub during tension and compression. The bearing is

locked in place by the hub because it is press-fitted to the rear knuckle.



Fig 7.1: Circlip (CAD) Isometric View



Fig 8.1: BKT AT 110 (CAD) Isometric View

8. TYRE

BKT- AT 110:

AT 110 is BKT's tire suitable for all-terrain applications with ATVs. Thanks to its extraordinary steering control, AT 110 is the ideal front axle tire for your vehicle.

Tyre size: AT 23 x 7 - 10

Load Capacity (Kg): 109 kg

. Speed selected: 100 km/h

. Pressure selection: 0.35 bar



Fig 8.2: Original BKT AT 110

9. COMPLETE ASSEMBLY

Starting with the tyre, it is attached to the sub-assembly via its connection with the wheel lobe situated in the hub using nuts and bolts. Moving forward, the disc lobe in the hub is connected to the brake disc, which is attached to the braking caliper through nuts and bolts. Furthermore, a taper roller bearing is fitted between the hub and the knuckle. Both lateral and torsional motions of the bearing are restricted, and only rotation is permitted. The knuckle restricts the translation of the hub from one end, while the hub restricts the translation from the other end. The Circlip is positioned in front of the knuckle in the designated spacing to prevent slippage. With the help of the A-arms, the knuckles are

connected to the main body frame. The splines generated within the cylindrical groove of the hub connect the axle to the hub. The completed CAD model of the Rear Wheel Assembly in SOLIDWORKS is shown in Figures 9.1 to 9.5.

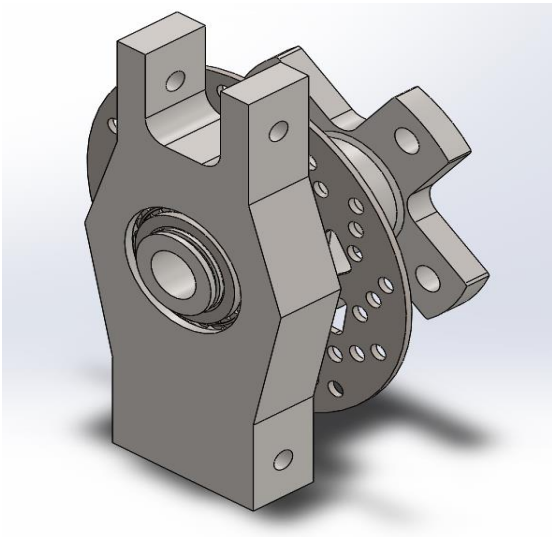

Fig 9.1: Rear Wheel Assembly Without Tyre (CAD)



Fig 9.2: Complete Rear Wheel Assembly (CAD)

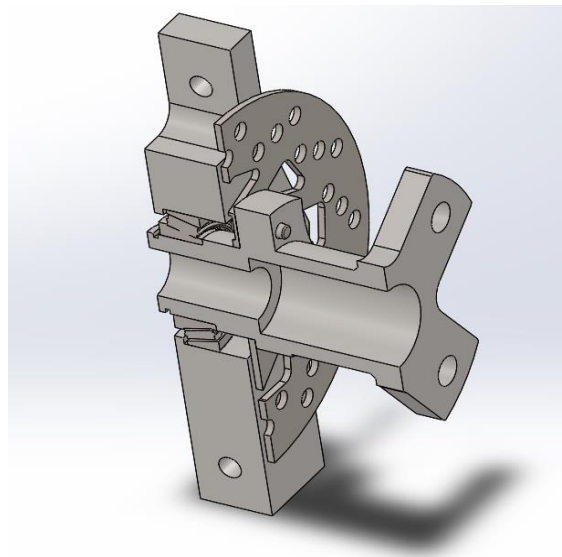

Fig 9.3: Sectional View of Rear Wheel Assembly (CAD)



Fig 9.4: Rear Wheel Assembly with A-Arms (CAD)



Fig 9.5: Completely Attached Rear Wheel Assembly (CAD)

10. ANALYSIS REPORT

10.1. STRESS ANALYSIS

- IS 1364- M12 x 50 x 30 – S

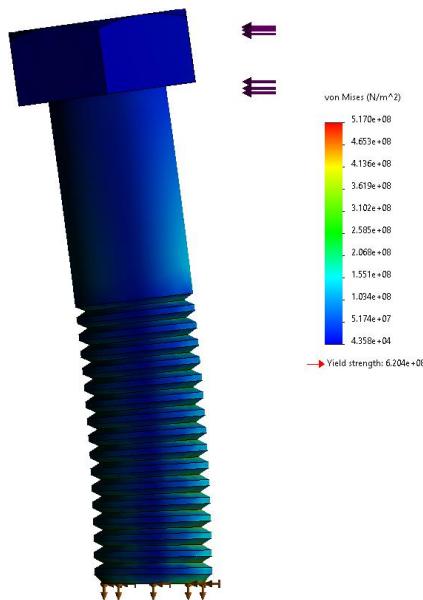

Fig 10.1.1: Stress Analysis of M12 bolt (Only Force)

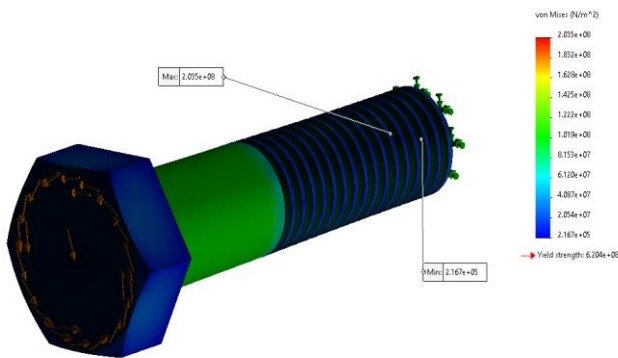

Fig 10.1.2: Stress Analysis of M12 bolt (Only Torque)

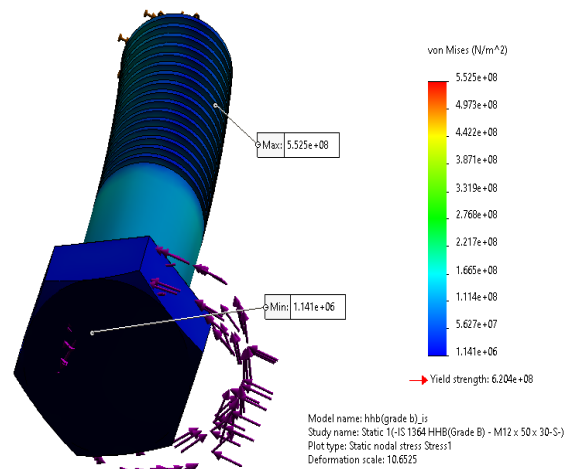

Fig 10.1.3: Stress Analysis of M12 bolt (Force and Torque)

- IS 2269- M6 x 16 – N

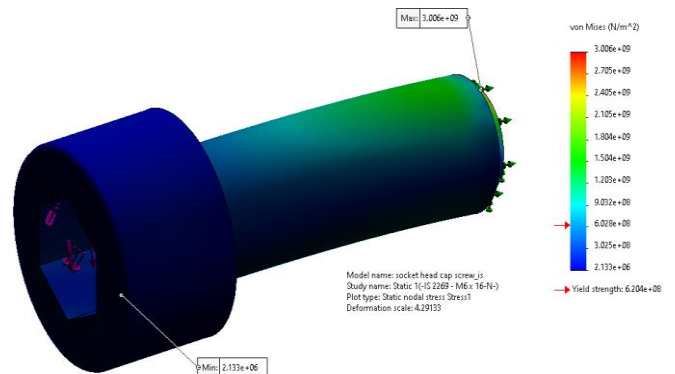

Fig 10.1.4: Stress Analysis of M6 bolt (Only Force)

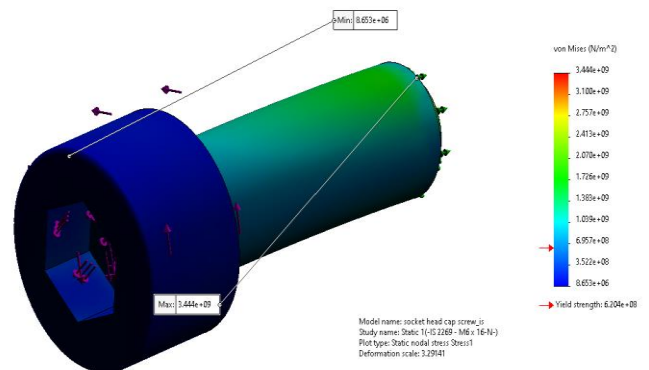

Fig 10.1.5: Stress Analysis of M6 bolt (Force and Torque)

- Knuckle

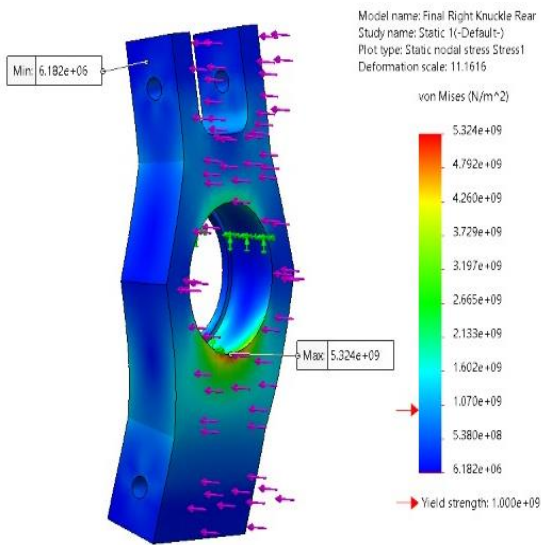

Fig 10.1.6: Stress Analysis of Knuckle

- Hub

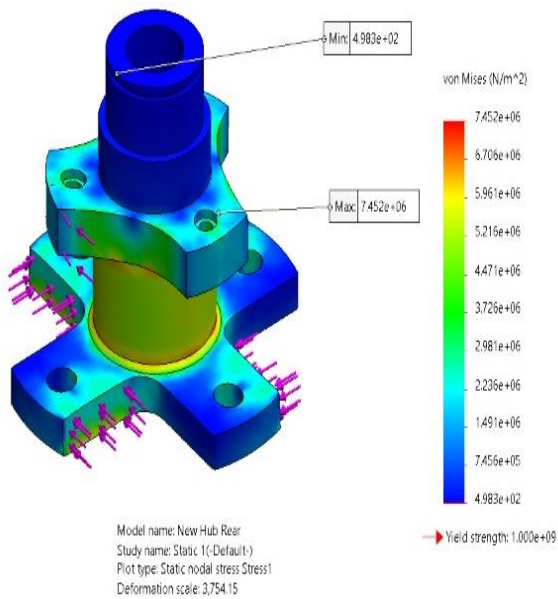

Fig 10.1.7: Stress Analysis of Hub

- Brake Disk

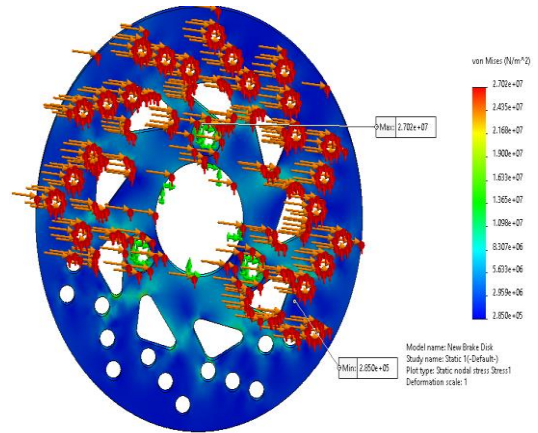

Fig 10.1.8: Stress Analysis of Brake disk

10.2. STRAIN ANALYSIS

- IS 1364- M12 x 50 x 30 – S

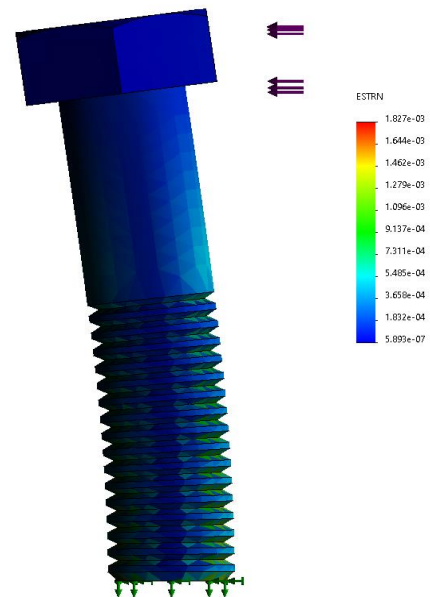

Fig 10.2.1: Strain Analysis of M12 bolt (Only Force)

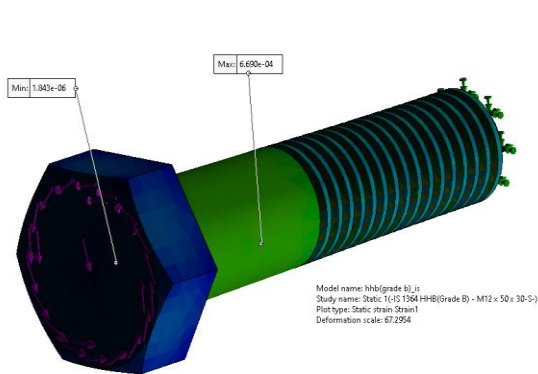

Fig 10.2.2: Strain Analysis of M12 bolt (Only Torque)

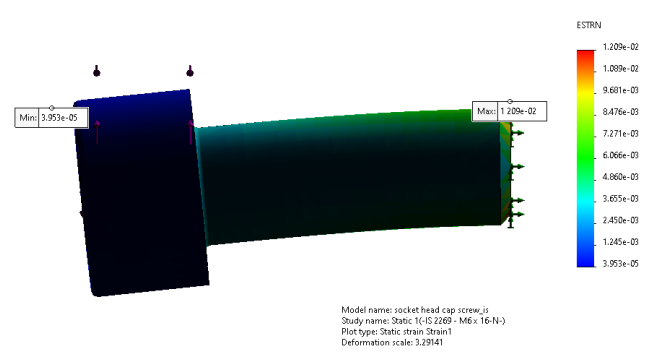

Fig 10.2.5: Strain Analysis of M6 bolt (Force and Torque)

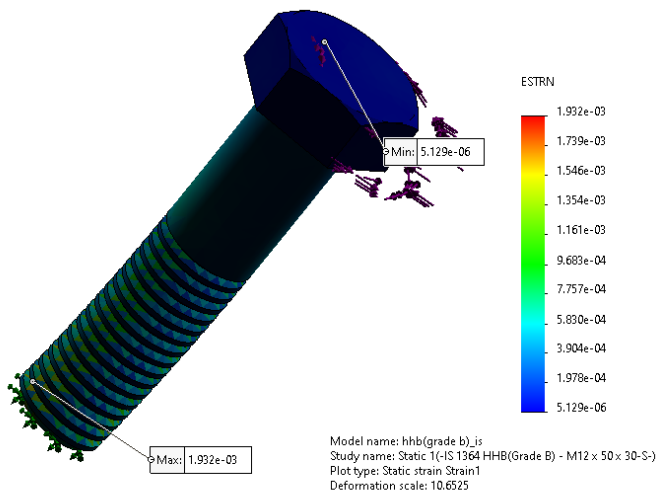

Fig 10.2.3: Strain Analysis of M12 bolt (Force and Torque)

- IS 2269- M6 x 16 – N

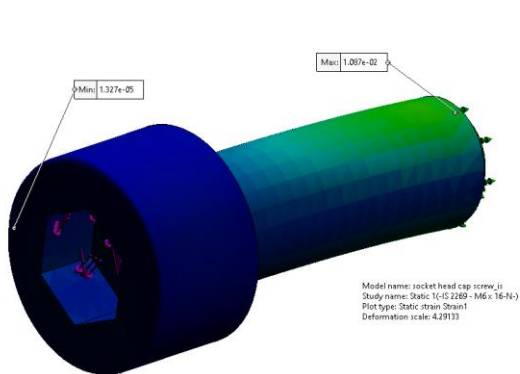

Fig 10.2.4: Strain Analysis of M6 bolt (Only Force)

- Knuckle

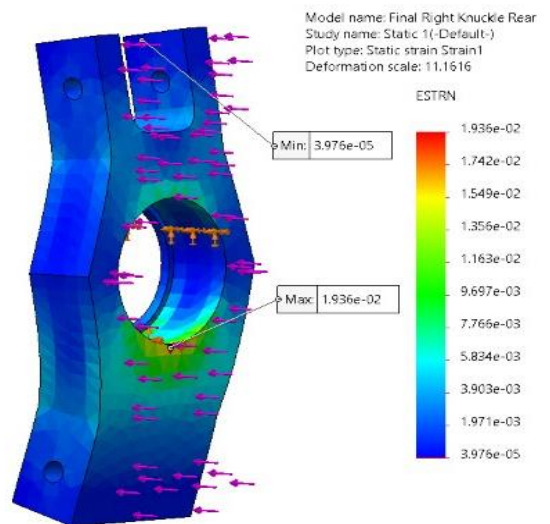

Fig 10.2.6: Strain Analysis of Knuckle

- Hub

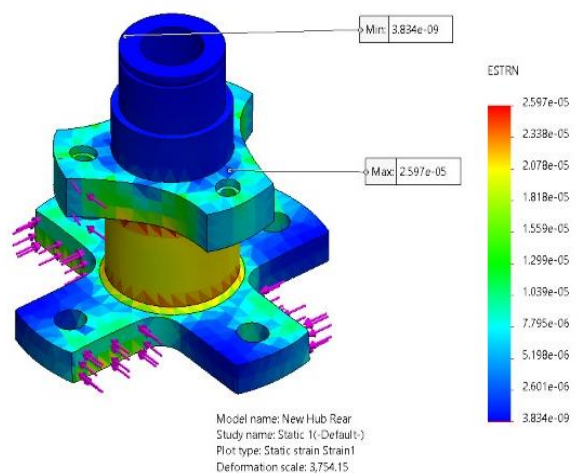

Fig 10.2.7: Strain Analysis of Hub

- Brake Disk

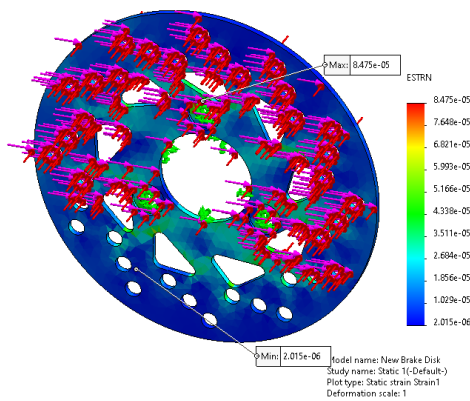

Fig 10.2.8: Strain Analysis of Brake disk

10.3. DISPLACEMENT ANALYSIS

- IS 1364- M12 x 50 x 30 – S

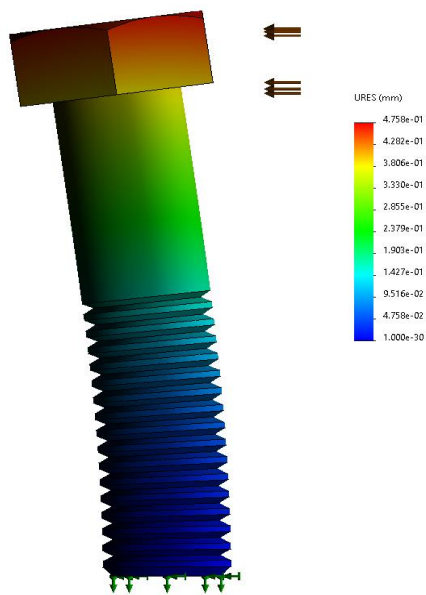

Fig 10.3.1: Displacement Analysis of M12 bolt

(Only Force)

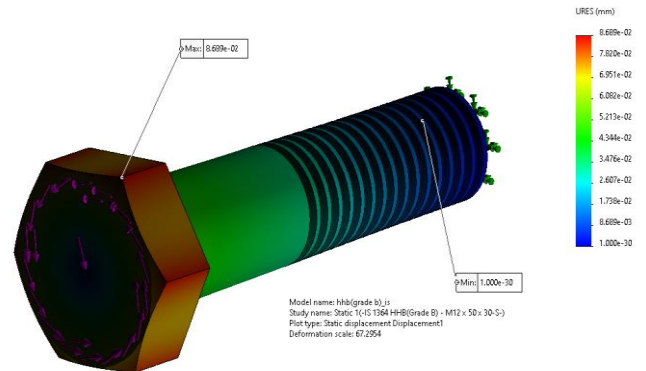

Fig 10.3.2: Displacement Analysis of M12 bolt

(Only Torque)

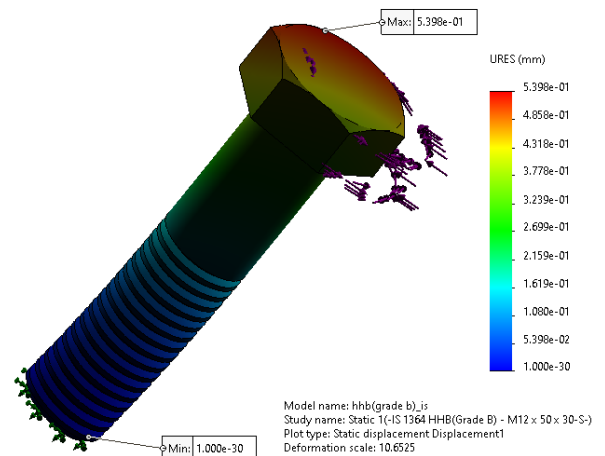

Fig 10.3.3: Displacement Analysis of M6 bolt

(Force and Torque)

- IS 2269- M6 x 16 – N

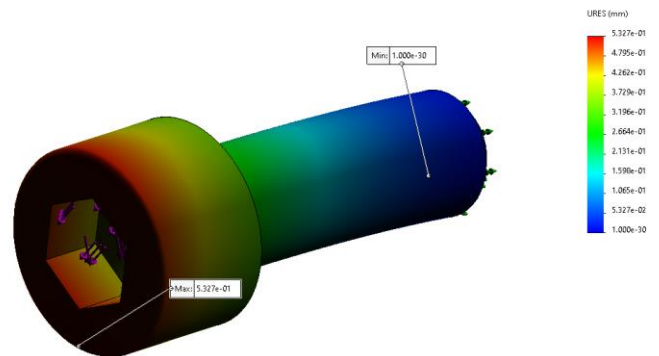

Fig 10.3.4: Displacement Analysis of M6 bolt (Only Force)

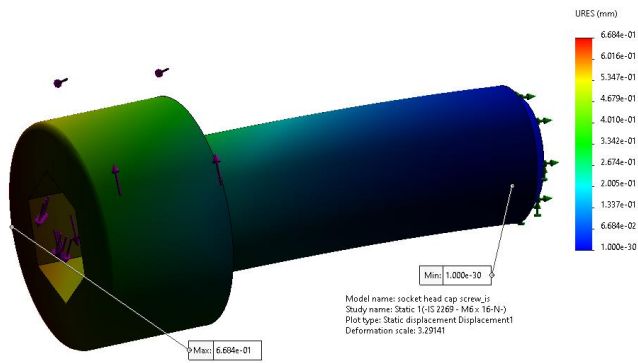

Fig 10.3.5: Displacement Analysis of M6 bolt
(Force and Torque)

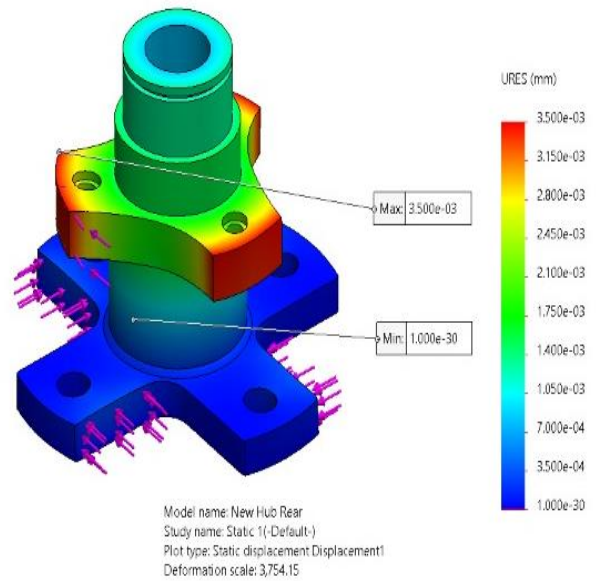

Fig 10.3.7: Displacement Analysis of Hub

- Knuckle

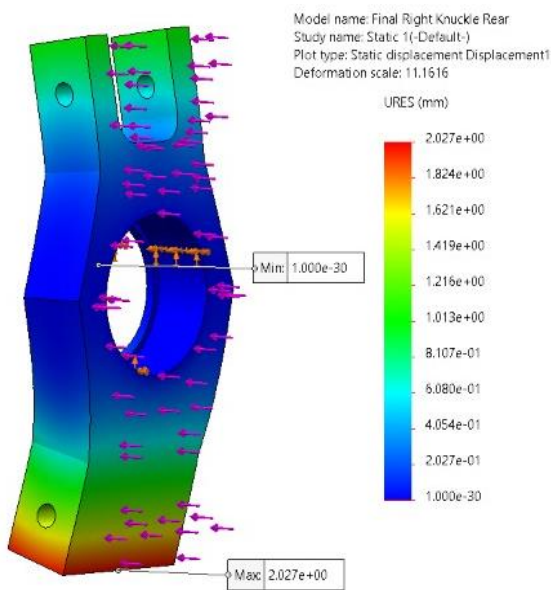

Fig 10.3.6: Displacement Analysis of Knuckle

- Hub

- Brake Disk

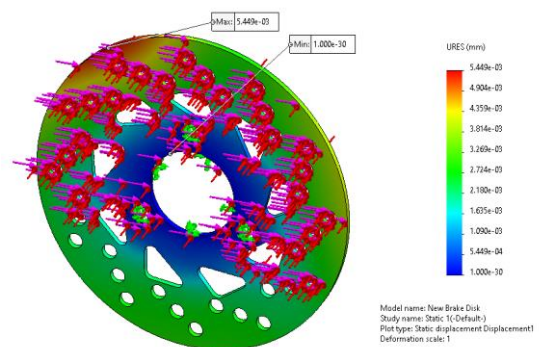

Fig 10.3.8: Displacement Analysis of Brake disk

11. THERMAL ANALYSIS OF BRAKE DISK

- Temperature

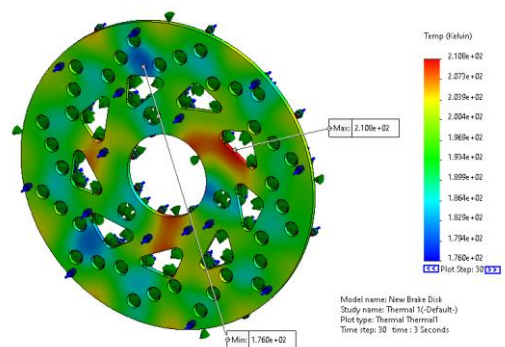

Fig 11.1: Thermal Analysis of Brake disk in Temperature

Resultant-Temperature-Gradient

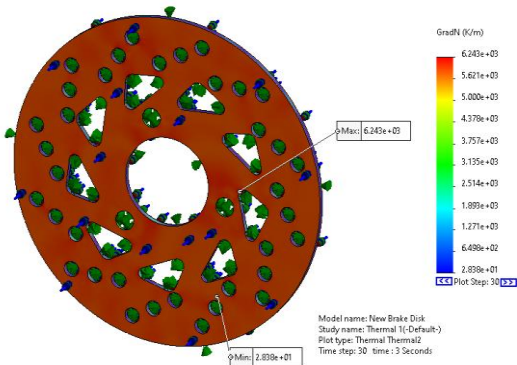

Fig 11.2: Thermal Analysis of Brake disk in Temperature gradient

Residual-Heat-Gradient

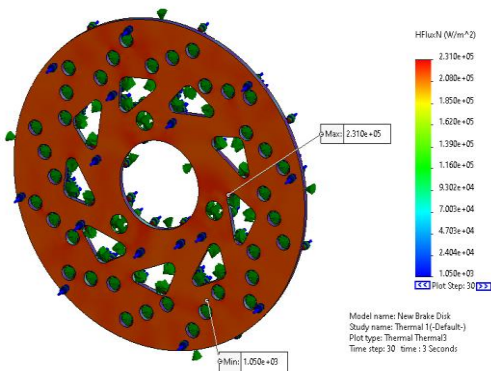

Fig 11.3: Thermal Analysis of Brake disk in Heat flux/gradient

12. RESULTS

- Here $1e-X = 10^{-X}$ and $1e+X = 10^{+X}$.

PARTS	STRESS (N/m ²)		RESULT
	MIN	MAX	
REAR KNUCKLE	6.18e+6	5.32e+9	Safe / Can be further Optimized.
REAR HUB	4.98e+2	7.45e+6	Safe / Can be further

			Optimized.
BOLT M6	8.65e+6	3.44e+9	Safe.
BRAKE DISK	2.85e+5	2.7e+7	Safe/ Depends on designer.
BOLT M12	2.16e+5	2.03e+8	Safe.

PARTS	STRAIN	
	MIN	MAX
REAR KNUCKLE	3.97e-5	1.93e-2
REAR HUB	3.83e-9	2.59e-5
BOLT M6	3.95e-5	1.20e-2
BRAKE DISK	2.015e-6	8.475e-5
11BOLT M12	1.84e-6	6.69e-4

13. CONCLUSIONS

The following points are summed up in this paper:

- The hard points are collected from the LOTUS suspension software.
- It is important to note that all the CAD models were build using SOLIDWORKS software.
- Analysis is carried out using SOLIDWORKS Simulation software.
- The ATV is safe as the rear wheel assembly is safe as seen in the analysis.
- Due to optimization in design, cost reduction, material reduction, and efficiency improvement was achieved.

6. We were able to minimize the total cost, weight, and strength by using EN 24 instead of AL 7075 for the Hub and Knuckle.
7. Having interchangeable hub and knuckle improves reusability and lower costs.

14. REFERENCES

- [1] FMAE's QBDC Season 2020 Rulebook.
- [2] Mohit Pillai, Aryan Dubey, and Pranay Gupta- "Design and Analysis of Front and Rear Wheel Assembly of an ATV", International Research Journal of Engineering and Technology, e-ISSN: 2395-0056 p-ISSN: 2395-0072 Volume: 07 Issue: 04 | Apr 2020.
- [3] Sameer Santosh Mahadik- "Design and ANSYS analysis of Components of Wheel Assembly of SAE Car", | International Journal of Current Engineering and Technology, E-ISSN 2277 - 4106, P-ISSN 2347 - 5161 Vol.8, No.2 (March/April 2018).
- [4] Sarvesh Kalejwar, Shiv Prakash Shukla, and Ishwar Gupta- "DESIGN AND ANALYSIS OF SAE BAJA VEHICLE WHEEL ASSEMBLY", International Journal of Creative Research Thoughts, IJCRT 1812571 | Volume 6, Issue 2 April 2018 | ISSN: 2320-2882.
- [5] Prof. Dr. G.P. Deshmukh, Prof. Pornima T. Godbole, Omkar R. Totre, Ronak R. Sarkar, Ashish A. Jadhav, and Ganesh P. Avahad- "Design, Optimization and ANSYS analysis of component of ATV wheel assembly", International Research Journal of Engineering and Technology, IRJET V815228 e-ISSN: 2395-0056 p-ISSN: 2395-0072 Volume: 08 Issue: 05 | May 2021.
- [6] Madhura Y. Sawatkar, Nitinchand G. Yadav, Asitkumar A. More, and Ajit N. Tupe- "DESIGN AND ANALYSIS OF ATV WHEEL ASSEMBLY", International Research Journal of Engineering and Technology, IRJET V815367 e-ISSN: 2395-0056 p-ISSN: 2395-0072 Volume: 08 Issue: 05 | May 2021.