

DESIGN AND MANUFACTURING OF ARDUINO OPERATED SANITIZER SPRAY ROBOT

Aditya Avinash Jadhav ¹, Girish Pramod Chaudhari ², Dr. Rajiv Ramchandra Saraf ³

^{1,2}(Dept. of Mechanical Engineering Government Polytechnic, Pune- 411016)

³(Lecturer, (Selection Grade), Dept. of Mechanical Engineering Government Polytechnic, Pune- 411016)

Abstract - This Robot is meant for COVID wards where sanitization of the place is critical regularly. The vehicle is wireless and self propelled with a battery and is controlled by Arduino and IR (Infrared) remote. We can also use Bluetooth and radio frequency remote for its direction control. We've a reservoir for sanitizer which incorporates a submersible pump which is also controlled by Arduino. The output of the pump is fed to a nozzle assembly via a flexible pipe and this assembly is carried on the vehicle body. As the vehicle moves forward, it sanitizes the path that the vehicle follows. It minimizing the hassle required to sanitize the place with the assistance of remote operation.

The main aim of our project is to provide technology-driven solutions to help doctors, nurses, other health workers and to minimize human contact as much as possible and thus automating the tasks such as sanitization with the help of robots. In this case, the use of robots can reduce human exposure to viruses, which has become increasingly important in pandemic.

Key Words: Arduino Uno, IR Remote, sanitization, epidemic.

1. INTRODUCTION

Corona Virus disease (Covid-19) is causing serious harm to the mankind. Since the outbreak of the virus, many cities are under lockdown, people are not able to step out of their homes and already thousands have lost their lives.

Spread of the virus that has infected more than 218,560,832 people globally and claimed more than 4,534,054 lives [As of September 1, 2021]. As the Covid-19 pandemic continues to unfold, washing and sanitization of hands have become an absolute necessity regularly.

In this global pandemic, robots are being used for jobs such as sanitizing hospitals and delivering food and medicines, and have proved to be very much useful and handy.

Health Organizations have advised physical distancing for people around the world to prevent community level transmission of Covid-19 and quarantine infected people effectively. Nowadays, Robots are also being deployed for administering treatment and providing support to quarantined patients.

Sanitization, which has become a really important aspect in these pandemic times and plays an essential role in preventing us from exposure of this deadly virus and thus helping in eradication of this global pandemic, is incredibly important. One of the high-risk zones of exposure to the deadly virus is in the hospitals and the medical wards.

Sanitization in these areas is very challenging and requires very high measures to be taken. But in spite of these high-end measures taken, there's always a risk involved with it.

2. COMPONENTS AND PRINCIPLE OF OPERATION

This Robot is meant for COVID wards where sanitization of the place is important. The vehicle is wireless and self propelled with an electric battery and is controlled by Arduino and IR remote. We can also use Bluetooth and radio frequency remote for its direction control.

We have a reservoir for sanitizer which encompasses submersible pump which is also controlled by Arduino. The output of the pump is fed to a nozzle assembly via a flexible pipe and this assembly is fixed on the vehicle body. As the vehicle moves forward, it sanitizes the path that the vehicle follows. It minimizing the hassle required to sanitize the place with the assistance of remote operation.

The various components are arranged as shown in the figure shown below,

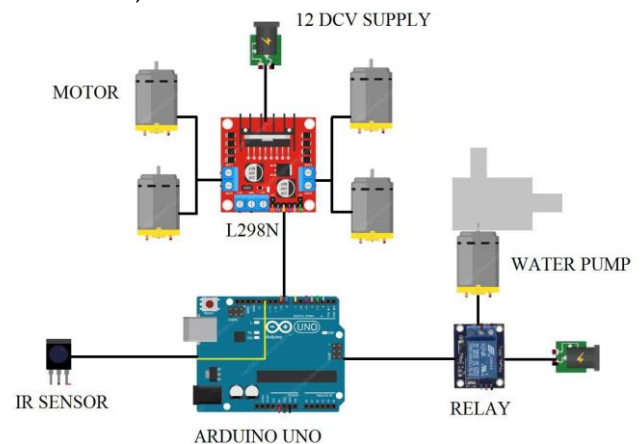

Fig -1: Schematic view of all basic components

2.1 Arduino Uno - The Arduino Uno is a controller which has mainly 3 regions- input, processor, storage, output. Input region receive data from Input devices like in our case IR Remote, and then the processor processes this data. Then this data is compared with stored data i.e program/code and an output is generated by processor and fed to output region.

2.2 L298N Driver Module - The L298N is an expansion board which allows speed and direction control of two DC motors at the identical time between 5 and 35V, with a peak current up to 2A. We connect 2 motors in series and then

connect this parallel connection to the board, so we get pair of two parallel motors as shown in the figure aside.

2.3 DC Diaphragm Water Pump - It is an perfect pump for variety of liquid movement application. It produces enough pressure to be used with nozzle to create spray system. The pump can suck water through the tube from up to 2m and pump water vertically for up to 3m.

2.4 Relay- Single Channel – We need a relay to control Pump as it cannot be directly controlled by Arduino as its voltage and current ratings can damage the board permanently. So we control a Relay with Arduino and this relay further controls pump.

2.5 IR Remote and Receiver – When a key on IR Remote is pressed, a Modulated signal is generated which is received by receiver. This received signal is further send to Arduino in the Digital format which is further interpreted based on coding stored in the Arduino

2.6 Geared Motor - DC Gearbox Motor with a gear ratio of 1:48. These motors can run from 3VDC up to 6VDC; these will run faster at the upper voltages.

3. CIRCUITRY

The Sanitizing Robot consist of total 3 different circuits combined together to form a complete Robot. The Arduino Board is the main processing unit which has program stored in it. Second important unit is L298N Driver Module. It is a unit which controls set of Motors and this unit receives signal for the operation from the Arduino Board via cables. Then we have a Relay which operates the Sanitizer Pump. We require a relay because Arduino cannot provide the required current and voltage to the Pump for its operation. Three different circuits in the Robot are,

- Propelling Circuit / Driver Circuit
- Sanitizer Pump Circuit
- IR Remote Control Circuit

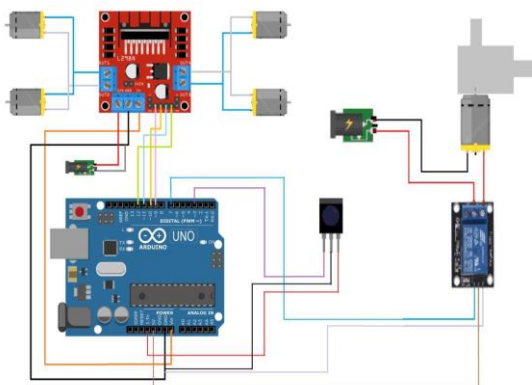

Fig -2: Circuit Connections

All the three circuits mentioned earlier are combined together to form complete Robot Circuitry. The vehicle is wireless and self propelled with a battery and is controlled by Ardiuno and IR remote. We can also use bluetooth and radio frequency remote for its direction control.

When the User presses the button on the remote, a signal is generated by it which is sent to IR Receiver which further receives and converts the signal into required form, in our case it is hexadecimal number.

Hexadecimal numbers are calibrated to give particular output. When the output signal is generated by the Arduino Uno, it is fed to Relay and L298N Module which perform required function.

In this way, Vehicle Motors (that are 4 in number) and Sanitizer Pump are controlled to give operation. The schematic view of the combined circuit is given on the next page. This whole circuitry is assembled on vehicle body.

4. ASSEMBLING THE ROBOT

The Assembly consists of numerous components connected together with the help of various mechanical methods. The components are described in Article 2. For the assembly purpose, we have taken ABS Sheet and a Frame for providing reinforcement and rigidity to the structure.

To describe the Assembly in brief, we have connected Geared Motors to the Frame and this Frame is then attached to the ABS (Acrylonitrile-Butadlene-Styrene) Sheet. On the ABS Sheet there are numerous other attachments like Remote Sensor Holder, Nozzle Holder, and Electrical Switch with a 12V Power Supply so as to turn ON or OFF the robot as per requirement.

Various view of the Robot generated in CREO Parametric are shown on the next page,

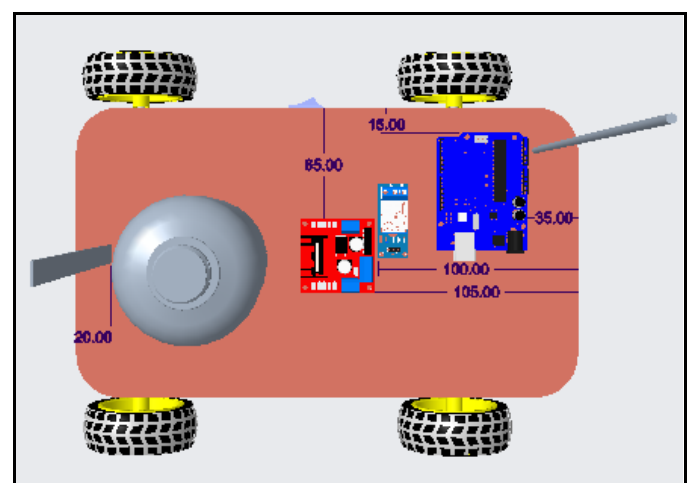

Fig -3: Top View of the Robot Unit

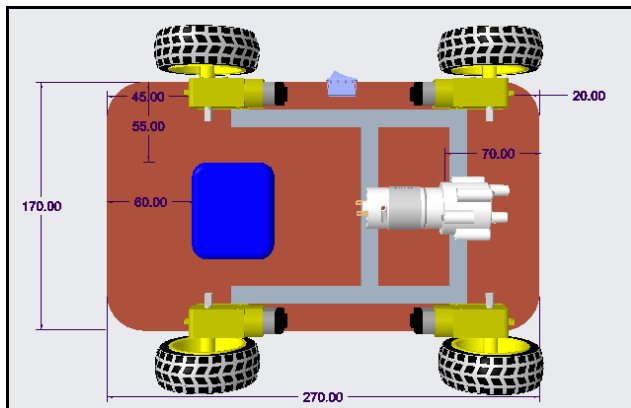

Fig -4: Bottom View of the Robot Unit

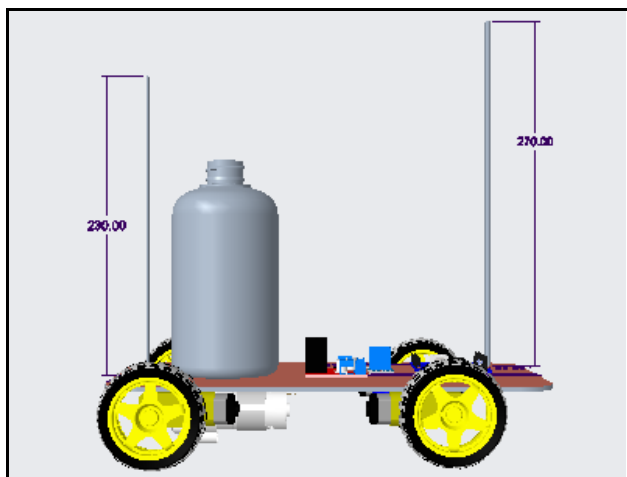

Fig -5: Side View of the Robot Unit

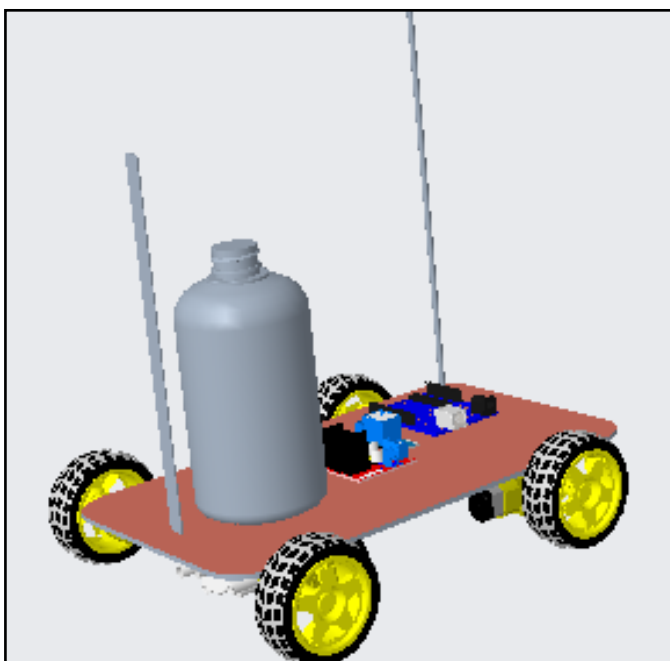

Fig -6: 3 Dimensional View of the Robot Unit

5. OPERATING THE ROBOT

The Robot consist of total 3 different circuits, these are-

- Propelling Circuit / Driver Circuit
- Sanitizer Pump Circuit
- IR Remote Control Circuit

The Robot is controlled through a Remote through IR Sensor. All the desired buttons on the remote are calibrated to give out a particular output at the output ports of Arduino Uno Board.

When we press a button on the remote, a signal is generated and sent to the IR Sensor. Now IR Sensor receives the signal and sends it to input port of the Arduino Uno Board. With the help of the code written, Arduino compares the input signal and generates a signal which is fed to output ports of the Arduino. In this way the input is handled by the Robot with the help of IR Remote Control Circuit.

Now based upon the signal fed to the outputs of the board, two other circuits operate to carry out the required function. First circuit is Propelling or Driver Circuit, it consists of L298N Driver Module and Pair of Geared Motors connected in parallel. When a signal is received by L298N Module, it regulates the speed (Set in the code) and direction (Maybe clockwise or anti-clockwise) and thus propelling the Robot in required direction. The figure below shows the basic structure of vehicle (Top View).

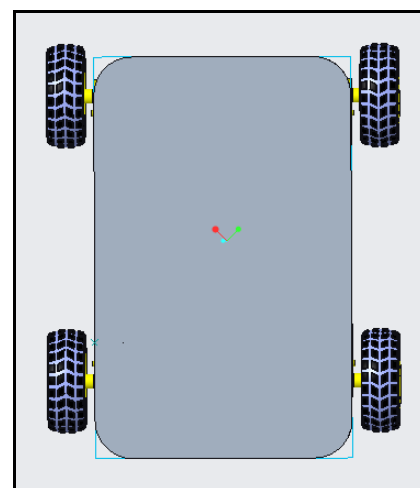

Fig -7: Vehicle's Top View

The code into the Arduino includes following directions in which the vehicle can be propelled -

- Forward Direction - When all the four wheels are turning in forward direction.

- Backward Direction - When all the four wheels are turning in reverse direction.
- Rightward Direction - When left side wheels are turning in forward direction, vehicle is pushed in rightward direction.
- Leftward Direction - When right side wheels are turning in forward direction, vehicle is pushed in leftward direction.
- Reverse Rightward Direction - When left side wheels are turning in reverse direction, vehicle is pushed in reverse rightward direction.
- Reverse Leftward Direction - When right side wheels are turning in reverse direction, vehicle is pushed in reverse leftward direction.
- Stopped - When no wheel is turning.

- By use of Radio Frequency Remote, its Range can be increased.
- By integration with IoT, its use can be made fully automated and the user can control the device from anywhere in the world.

Now the second circuit operating is Sanitizing Pump Circuit. It consists of a relay, pump, necessary tubing, reservoir and a nozzle. The relay receives signal from Arduino Uno through output port. It then connects or disconnects the pump from the power supply depending whether the circuit is normally open or normally close (in our case its normally open). When the relay receives the signal, it closes the circuit, which switch on the pump and it sprays the sanitizer through the nozzle.

6. RESULTS AND DISCUSSION

Operation of the Robot with a Remote is user-friendly. While it was tested, following results were obtained,

- Robot Weight = 0.95 kg
- Vehicle Speed = 0.15 m/s
- Flow Rate = 0.005 lit/s
- Head of the Pump = 1 m
- Throw of Nozzle = 0.45 m
- Capacity of Tank = 0.5 lit
- Possible Run Time of Robot = 45 minutes

We have used a battery of rating 12 Volts and 1200 mAh. Motors together consume 1 Ampere current and Pump consumes around 0.8 Ampere current. The torque produced by the motors is around 7.8 N.cm.

7. FUTURE SCOPE

The improvements which can be incorporated into the Robot are immense. The improvements will not only increase the capabilities but will also increase efficiency and its applications. Some of the improvements that can be incorporated are,

- Integration with Solar Energy.
- By adopting Hydraulic system to wheels, the Ground clearance can be easily adjusted.
- The use of Latest computer technology will make to automate the system completely.

8. CONCLUSIONS

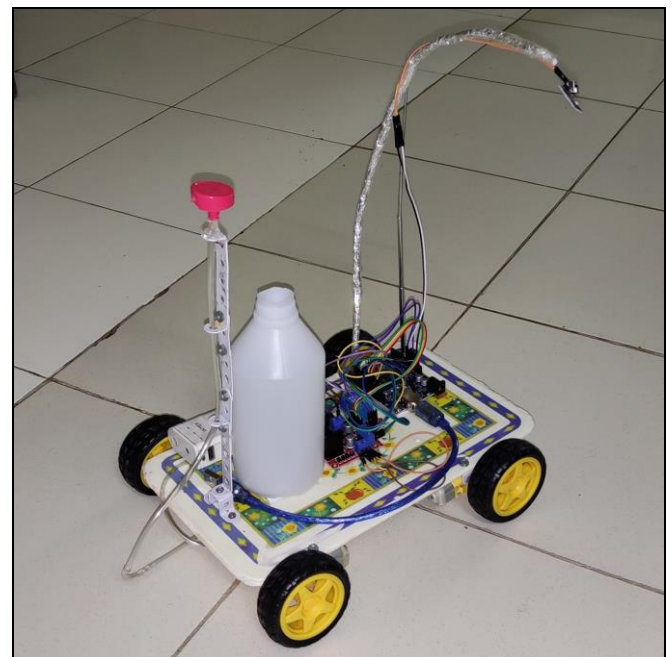

Fig -8 Actual View of the Robot

There is a huge robotics potential in medical and other areas with special relation to the control of the COVID-19 pandemic, this can significantly reduce the number of infected patients and casualties. The introduction of medical robotics can significantly impact the health management systems in positive way.

REFERENCES

- [1] www.startus-insights.com
- [2] www.canonicalrobots.com
- [3] www.scribd.com
- [4] www.howstuffworks.com
- [5] www.toptechboy.com