

## Design of Waterless Solar Panel Cleaning System

Jay M. Makani<sup>1</sup>, Vraj B. Patel<sup>2</sup>, Aman J. Sharma<sup>3</sup>, Meet M. Patel<sup>4</sup>, Harsh A. Patel<sup>5</sup>

<sup>1-3</sup>Mechanical Engineer, L.J. institute of Engineering and Technology, Ahmedabad, Gujarat, India

<sup>4</sup>B. Tech final year (Automobile), IITE Indus University, Ahmedabad, Gujarat, India

<sup>5</sup>UG student in Computer Engineering, L.J. institute of Engineering and Technology, Ahmedabad, Gujarat, India

\*\*\*

**Abstract** - Energy is one among the main issues that the planet is facing in India, the availability of energy has been one among the main problems for both urban and rural households. Approximately 60% to 70% of the energy requirement of the country is fulfilled by fuelwood and agriculture residues. Solar energy is a continuous source of energy, which has great potential and is discharged by the sun. Renewable energy is vital to exchange the utilization of electrical energy generated by petroleum. Solar power has become a source of renewable energy and solar power application should be enhanced. Solar PV modules are generally equipped in dusty atmosphere which is that the case in tropical countries like India, UAE etc. The dust gets piled up on the upper surface of the module and blocks the incident of direct light from the sun. It lessens the facility generation capacity of the Solar PV module. The power output reduces as greater as 50% if the module is not cleaned for a month. To clean the dust every day, an automatic cleaning system has been developed, which detects the dust on the solar array and also cleans the module by itself. In terms of daily energy generation, the presented automatic-cleaning machine is more costly and bulky compared to our solution.

output per month, for the period of the investigation is shown in Fig. (1). Moreover, in such arid regions if water is available the water contains a highly soluble salt which damages the panels.

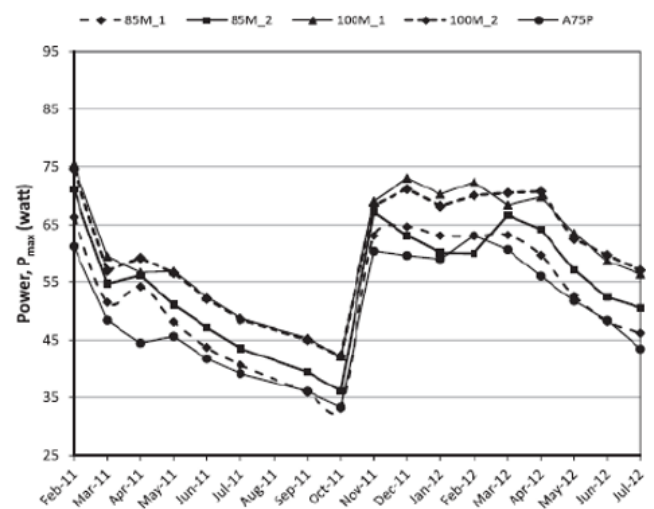

Figure -1: Monthly Power output from Solar Panel

**Key Words:** Waterless Cleaning, Dry cleaning, Solar Panel, Cleaning Robot, Cleaning System

### 1.INTRODUCTION

Several environmental factors such as wind speed, humidity, ambient temperature, solar radiation, atmospheric dust and direction influence the power generation process using installed solar photovoltaic modules. Dust build-up on solar module surface is an problem of great worry, particularly in desert provinces where infrequent to regular dust storms do occur. The glass cover transmittance decreases because of the accretion of dust on the surface of the PV module, which ultimately decreases the amount of solar irradiation reaching the cells. The dust density of the surface, orientation, tilt angle, exposure period, dominant wind direction, and site climatic conditions determine the reduction in glass transmittance. The density of deposited dust, the composition of the dust and its particle distribution determines the effect of dust on the power output and current-voltage (I~V) characteristics of PV modules. Surveys in Arid regions to study the effect of dust amassing on the power production of the solar module have revealed that power given by the modules declined constantly due to dust addition. Pmax which is the average of daily peak power

### 1.1 Overview

Nowadays the world moving towards starting the use of renewable energy mostly solar energy is used to generate electricity. In developing countries like India solar modules suffers from a dusty environment due to dust particles efficiency of solar panel reduces. This dust accumulated on the glass surface of the solar PV panel. In the winter seasons, this dust is a thick cover of dust on the surface of the panel due to dewdrops. This dust blocks sun rays which are very useful to generate electricity. But due to this dust, the output of solar PV is reduced up to 50% of its rating, if it is not cleaned. Therefore, cleaning the solar PV module is a necessary activity but it required manpower, time and water. But there are several arid regions where farming is not at all possible and the Indian government is trying to set solar farms there. Due to the lack of water availability in such regions, we planned to manufacture an automatic product to clean the panels which is affordable and easy to use. In a previous technology, the wiper mechanism is used to clean the solar panel or also sprayer mechanism is used to clean the solar panel but such a system requires high water quantity and water should not be salty too. In this paper, we discuss the design of a waterless cleaning system that is useful to increase solar panel efficiency and avoid maintenance.

## 1.2 Objectives

The Main Aim of the Project is: To maximize the energy production by solar panels in desert areas, in arid regions, at low expense and without the impact of manual. While cutting costs, the performance of the photovoltaic panel in solar farms should be optimized. The Major Factors Consider while Developing the System are: Robot should be compact; also, it should be maintenance-free. It should clean the panels automatically. The material used for cleaning the solar farms should not damage the panels. To overcome on above Problems following steps has been taken: The design should be easy to manufacture, low cost. Design has been drawn in AutoCAD for better understanding. After analyzing all the calculations and design manufacturing has been done.

## 2. Literature Survey

Some of the researcher had done work on the manufacturing of automatic solar cleaning systems. They used different cleaning techniques; some of the researcher had used different acids to clean panels. Some of the research work was surveyed by us.

1. Williams R B. et. al, in this paper author has worked on a particular downfall of Electrodynamics Screen (EDS) and tried to resolve it by providing an integrated approach. An EDS based system requires a high-voltage external power source for its operation, but the EDS can be made self-sustainable with the power output from the PV cell itself. Author incorporates a transparent EDS with a PV array as its power source to make itself sustainable.
2. Sharma R, Wyatt C A, Zhang Jing, et al., in this paper authors had also worked on EDS technology. The outcome of this research was a modified technique with high dust removal efficiency. It was researched especially for the future space programs.

## 3. Materials and methods

### 3.1 Working of Mechanism

Following the dimensions of the flat plate panel, the solar panel cleaning system consists of a microfiber brush driven by DC motors and the actions of brushes are controlled by a remote. The frame carrying that cleaning brush is moved along the length of the solar panel in a horizontal direction and vice versa, which results in mopping action on the solar panel cleaning the panels. That frame is also consisting of DC motors which will produce the rotational motion which is converted into linear motion. This action is also controlled by the remote. The shifting of the frame from one solar panel row to another solar panel row is done manually or by using multiple systems. The system can be moved in a horizontal direction until the solar panel row ends. All these cleaning actions will take around 80sec for mopping action, for cleaning the one solar panel of dimension 1956-990-40(mm). Once one row of the solar panel is cleaned, it moves

to another row and hence the cleaning process gets repeats until we got maximum power output. The whole mechanism mainly consists of the Moving Assembly and Cleaning Assembly.

### 3.2 Moving Assembly

The moving assembly of the cleaning system made of Aluminum T-section to support the cleaning assembly and G-channels with wheels were used to move the cleaning assembly to and from for cleaning. The box frame moving assembly makes sure the appropriate speed is required and also covers the whole portion of panels. The whole assembly is moved with the help of two types of wheels – Main wheels and Guiding wheels, both connected with high torque two-way motors.

### 3.3 Cleaning Assembly

The cleaning assembly in solar panel cleaning consists of a microfiber brush to clean without the use of water. The brush is supported by a shaft connected to a high rpm motor at one end. With the high rpm motor of 100 rpm and due to high-speed rotation of the brush the dust is removed from the surface and the panel is cleaned efficiently.

### 3.4 Main Components

#### 3.4.1 Frame

This is made of Aluminum T slots. The whole parts are mounted on this frame structure with a suitable arrangement. Boring of bearing sizes and open bores done in one sitting to align the bearings properly while assembling. Provisions are made to cover the bearings with grease.



Figure -2: Cleaning Assembly

#### 3.4.2 Power Supply

A 12V power supply adapter is provided in the system for the power supply. It also has a 12V battery space, which can hold a battery which once charged runs for 8-10hrs.

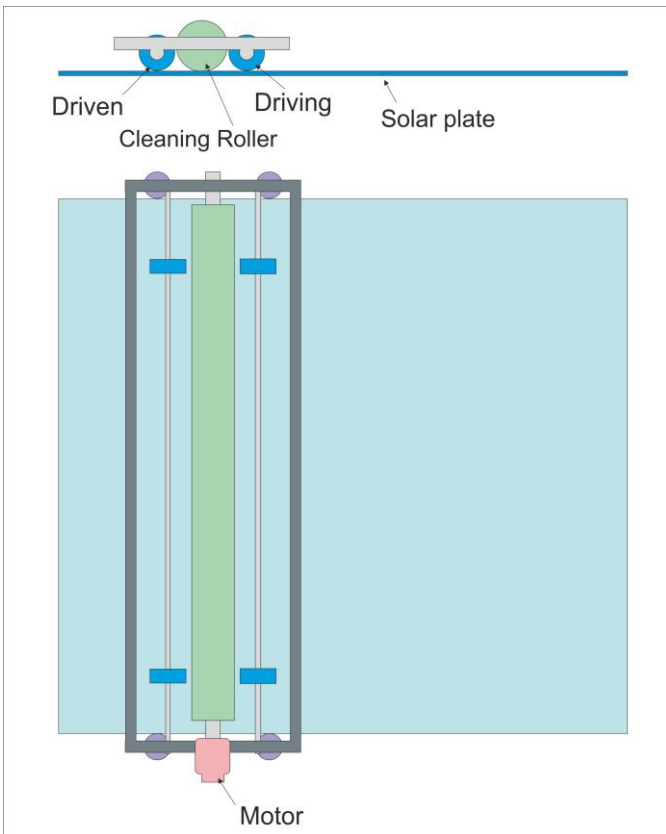

Figure -3: Moving Assembly



Figure -5: 30RPM DC Motor

### 3.4.4 Roller Brush

The roller brush is made up of microfiber materials. The material is selected such that it does not damage the surface of the panel and when it is rotated with high rpm speed it does efficient cleaning without the requirement of water.

### 3.4.5 Nylon Wheels

Nylon wheels are used to provide motion to the assembly on the surface of the solar panel. The sample of nylon wheel is shown in figure (5).

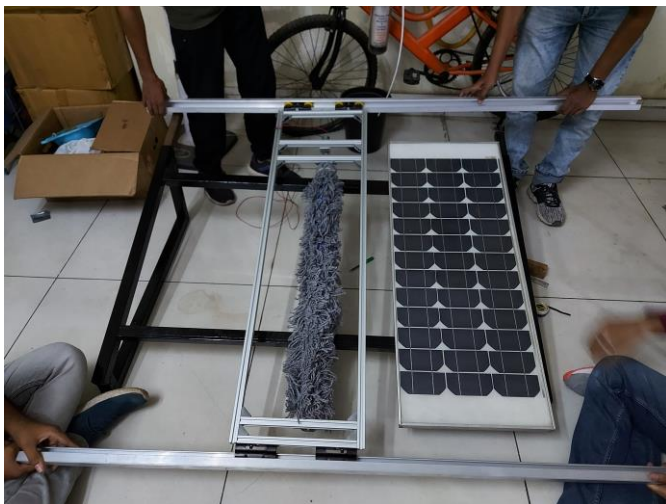

Figure -4: Frame

### 3.4.3 DC Motor

The motor is used to drive the cleaning unit. 30RPM Johnson motor was used to drive the system. It was a high-grade motor with high torque for driving the system.



Figure -6: Nylon Wheel

## 4. Design and Prototypes

### 4.1 Top View

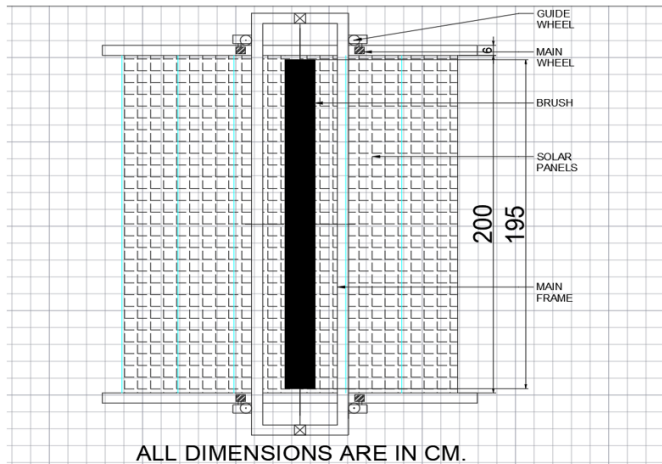

Figure -7: Top View

### 4.2 Side View

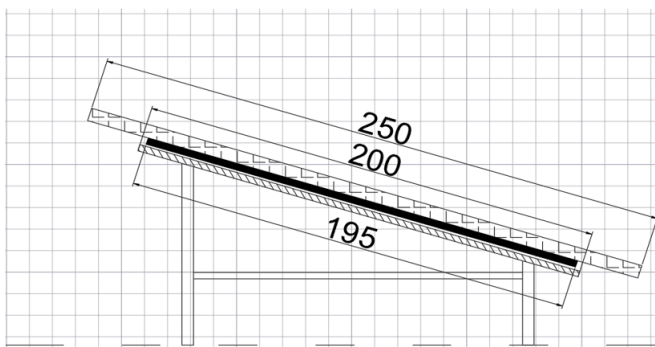

Figure -8: Side View

### 4.3 Prototypes

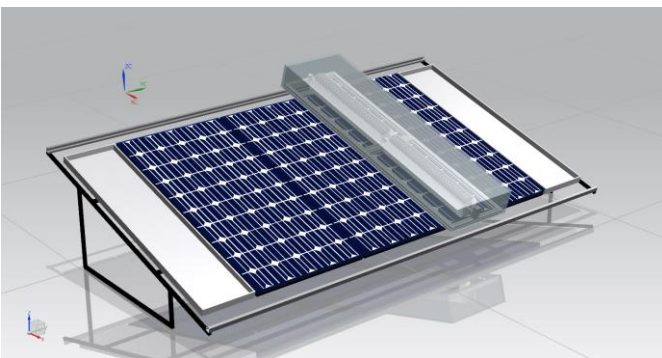

Figure -9: 3D Design



Figure -10 Real Time Model

## 5. Discussion and Calculation

The following tables show the expected results of power generation without and with the use of a solar panel cleaning system:

Day	Voltage (V)	Current (amp)	Power (watt)
1	15.60	1.25	19.5
2	15.27	1.24	18.93
3	15.12	1.14	17.23
4	15.04	1.08	16.24
5	15.01	1.09	16.36
6	14.92	1.06	15.81

Table -1: Without Cleaning

Day	Voltage (V)	Current (amp)	Power (watt)
1	16.00	1.25	20
2	15.98	1.24	19.81
3	15.98	1.23	19.85
4	16.01	1.24	19.85
5	15.99	1.26	20.14
6	15.97	1.25	19.96

Table -2: With Cleaning

It is demonstrated that when the solar panel is in a tilted position the energy reduction is up to 10%. And, when the panel is not titled it goes up to around 40% of reduction. By observing table and table we can totally relate that cleaning is very important on daily basis.

### 5.1 Motor Calculation

Motor Type – High Torque Geared Motor

Operating Voltage = 12V (DC)

Motor speed at output shaft = 30RPM

Stall torque of motor = 120 Kg cm

Rated torque = Stall torque / Factor of safety  
 $= 120 / 3 = 40 \text{ Kg cm}$

(Considering FOS = 3 for the safety of motor)

Driving wheel Diameter D = 70 mm = 7 cm

Motor Torque  $T = 40 \text{ Kg cm}$   
Safety Weight for prototype  $W = ?$

Torque required for motion  
 $= \text{Weight } (W) * \text{Wheel radius } (OA) < \text{Motor torque}(T)$   
 $= W * 3.5 < 40 \quad (OA = D/2 = 7/2 = 3.5\text{mm})$

Hence, Allowable Weight for the system  $W < 11.42\text{Kg}$

We are using 2 motors for the prototype.  
So, 80Kgcm of torque would be preferable.  
We have considered a factor of safety \*2 for the calculation of the whole project.

Distance to revolution –  
Motor speed = 10 rpm  
i.e., 10 rotations per minute  
Wheel Diameter  $D = 70\text{mm} = 7 \text{ cm}$

Therefore, Circumference of Wheel  $= \pi D = 3.14 * 70 = 219.8$   
mm per 10 rotations  
Hence, Distance travelled by moving assembly in 1 minute,  
 $= 219.8 * 10$   
 $= 2198 \text{ mm}$

i.e., 3.66 mm per second  
The machine will travel 13.8 mph.  
Considering 30% of Loss for 1 MW plant every month,  
Total generation of powerplant = 1,20,000 units per month,  
Unit lost due to inefficient cleaning = 36,000 units per month,  
Price per unit = Rs 2 per unit (Minimal)  
Minimal loss =  $36,000 * 2 = \text{Rs. } 72,000$  Per month = Industrial cost of Machine  
Hence, we can say that each month we can have recovery of 1 Cleaning machine.

## 6. Conclusions

Existing automated cleaners mainly focus on the wet cleaning method for the cleaning of solar panels. But our project opens the perspective of efficient cleaning of solar panels by the method of wet cleaning where we can save water. The solar panel cleaning system was first designed taking into consideration the design parameters. Our model was tested and the following observations were made.

Hence, the whole idea behind this project was to save water and also to do efficient cleaning for the better power generations of solar panels. There are some limitations of this machine too, likewise, Brush maintenance is required, not as cheap as manual cleaning, Dry cleaning is not as efficient as wet cleaning. If talking about future scope Indian government is taking initiative for the development of arid regions by converting drylands into Solar farms where only dry cleaning of panels could be possible. In today's time, where we are facing water scarcity; dry cleaning of solar panels becomes a must-use thing. Expected outcomes are

like, it will stop wasting one renewable source for the cleaning of panels which is also a part of a renewable source of energy. Can be used in arid regions where solar energy is generated maximum but there is no availability of water.

## REFERENCES

- [1] Williams R B, Tanimoto R, Simonyan A, et al. Vibration characterization of self-cleaning solar panels with piezoceramic actuation. Collection of Technical Papers - 48th AIAA/ASME/ASCE/AHS/ASC Structures, Structural Dynamics, and Materials Conference, 2007; pp. 512-520.
- [2] Calle C I, McFall J L, Buhler C R, et al. Dust particle removal by electrostatic and dielectrophoretic forces with applications to NASA exploration missions. Proc. ESA Annual Meeting on Electrostatics, 2008; Paper O1.
- [3] Sharma R, Wyatt C A, Zhang Jing, et al. Experimental evaluation and analysis of electrodynamic screen as dust mitigation technology for future Mars missions. IEEE Transactions on Industry Applications, 2009; 45(2):591-596.
- [4] Tomoaki Yano, Tomohiro Suwa, Masato Muraxami And Takuji Yamamotoq Development of a Semi Self-contained Wall Climbing Robot with Scanning Type Suction Cups Intelligent Robots and Systems, 1997. IROS '97., Proceedings of the 1997 IEEE/RSJ International Conference.
- [5] <https://patents.google.com/patent/US9443992B2/en>.
- [6] <https://patents.google.com/patent/US8500918B1/en>.