

Conceptual Design of Glider Typed Flying Car

BILLI BHARGAV¹

¹ Student, Dept, of Electronics and Communication Engineering, Madanapalle institute of technology and science, Andhra Pradesh, India

Abstract - In the way of upgrading the man made transporting systems (road, water & air ways), Irrespective of advancement technology, as the increase in population all over the world causes a lot of problem in every day to day life in transport system.

In the recent decades, there was a lot of designs which will help in to create a new era in flying car design technology. flying cars has been a great advantages with a cumulative disadvantages. however, flying cars are not existing in the real world in behalf of difficulty in fabrication and more complexity in design. This paper represents the conceptual design of a glider typed flying car. In this context, this paper primarily focus on developing the design of potentially enhanced security car prototype with an immergence of glider technology in car. Due to the advanced emerging technologies in gliding along with its capabilities, a car can effectively fly in sky with a booster engine attached in backside which creates backward pressure which makes the car move forward. And moreover, in the obtained design car can be moved along with a wings. Although the wings can be folded automatically.

Key Words: Flying car, Glider, wings, design, prototype, hybrid vehicle.

1. INTRODUCTION

To date, transportation has always been a big problem. Setting aside the advancement in technology, the resource for developing or manufacturing the flying cars is very low.

With the fastening growth of technology, the continuous improvement in making people's living standards high, the development prospects of flying cars will have added vast. Flying car is one of the big revolution or a start of an new era. Because of the comprehensive driving ability in the land, water, marsh, and air, flying car has become a new concept of air-ground amphibious transport, especially the low operating costs which equivalent to 1/100 of the level of domestic helicopter, it can be quickly gained popularity and promotion [1]. Although, using GPS satellite positioning system and radar system. It can make sure that will enroute correctly and air flight safely. On the ground, it will seems like a normal car [2]. Nevertheless, the stability is the main overall issue which needs a particular angle of wing in order to fly steadily. Hang gliders have evolved into safe, efficient, and fun sport aircraft, Rigid wing gliders have achieved L/Ds in the 20s [3] [4]. One of the innovative framework in designing controllers for a VTOL aircraft with wing [5].

Flying cars can be used by customs, public security, and anti-smuggling patrols can be used, as well as for drug-dispensing mobile equipment. It can also be utilized for highway, railway, oil and gas pipeline, and optical cable patrol maintenance [6].

1.1 The Origin of Flying car

In 1917, the first flying car prototype has been designed although the prototype got failed with various reasons. The prototyping of designing of flying cars has not stopped till today. though, the new designs of the flying cars are coming till to the era. The substantiate of the cars is been violable.

A perfectly designed flying car will run like a normal car on the road parallel it should has the ability to fly like an aircraft with different types of capabilities. To date, the most developed or designed flying car's doesn't have the capacity to uphold the feature of flying. Flying cars will also help in reducing deforestation as flying doesn't need any road facilities. Thus, in order to reduce the global warming flying cars also play a significant role in enhancing the transportation which brings a new era in transportation system by reducing the traffic jam / blockage's which will gradually improves the standards of living across the globe. Flying has the devastating advantages which will bring down the usage of the helicopters. Flying cars are also helpful in key roles where rapid actions or fast rescues need to be taken such as in health care industry, police and in military for vigorous actions. Flying cars will help in fastening the transportation facilities and it will enable reduced infrastructure development such as bridges and so on. And will save a number of trees from being cut, for wood and other purposes helping the environment improve.

1.2 Challenges felt

In order to develop/ build a good road infrastructure several trees are been cutting. Especially, in the forest areas and cause of this several animals are losing their home lands which results in animals entering into civilized area. They can damage the houses by trampling over the areas. In some cases it will even cause death of humans.

In the Figure - 1.2.(a), shows the tiger roaming in human civilization places which will cause accidental deaths either of people or animal. Figure - 1.2.(b) shows an elephant aggressively running over a man which will cause deaths (of either humans or animals) in some cases and will causing financial problems to poor people.



Figure – 1.2(a), Tiger roaming near the houses.



Figure – 1.2(b), Elephant aggressively run over a man.

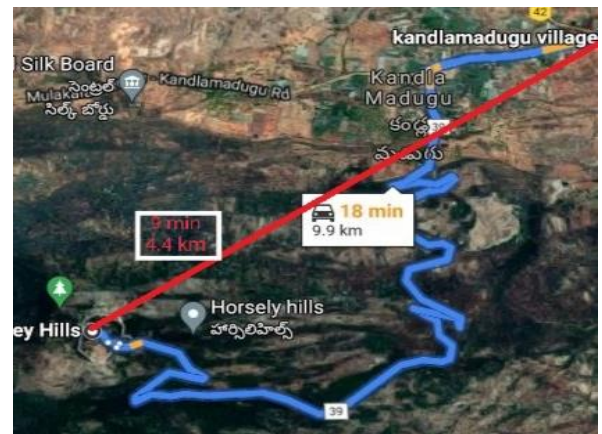

Figure – 2(a), Comparison of the distance between two paths.

This paper represents the design of the flying car in top, side views. In the figure 2(b), shows the top view of the car when the wings are folded. When the car is going or running on road like a normal car it will resembles the figure shown in 2(b).

2. PROPOSED DESIGN

The proposed conceptual design of flying car is a vertical take off landing (VTOL) mode. For the proposed design, which is a vertical flight, the flying car prototype is a glider type. So as it follows the principles of glider which makes it fly usually.

Plethora of research relating to the ground vehicles and also aerial vehicles among those flying car is the only thing which has the capability of flying like an aircraft and move on ground like a normal car. So far, the work done towards developing the infrastructure of road vehicles can be applied in advancing the flying car. The scientific advancement connected to electric and hybrid vehicle industry could be the new revolution in car technology.

The Figure – 2(a), Compares the distance and reach time to the destiny from the same starting point to the same location with different vehicles in which one can be reached via a normal car where as the other one is flying car. The red line indicates the shortest path which can be covered through the flying car and the blue line indicates the path of normal car which is very long in comparison to the red color path.

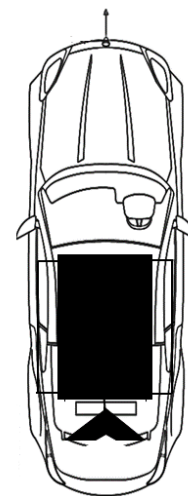

Figure – 2(b), Top view of the flying car when the car is folded.

The Figure – 2(c), shows the top view of flying car when the car is in flying mode where the glider wings are opened. When the car is motion on hill through the glider wings it can be able to fly by opening the wings which are folded when the car is moving on a road. And the tail is useful in turning towards the destiny of the driver.

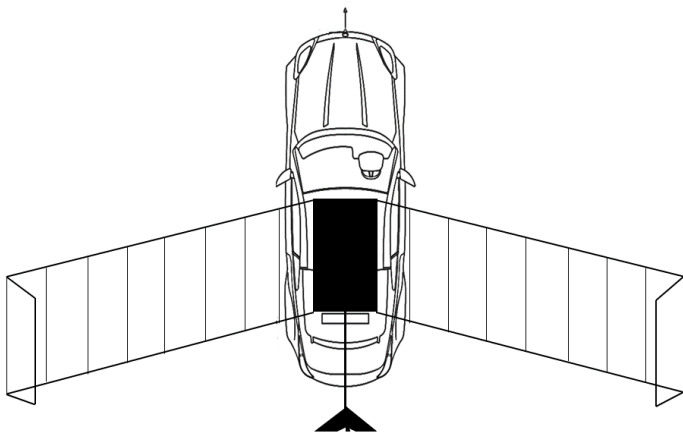

Figure – 2(c), Top view of the flying car when the wings are opened.

And the figure – 2(d), shows the image when the car is shifting from normal car to aero craft. The tail is very useful other than like normal aircraft which are useful in pointing towards the direction.

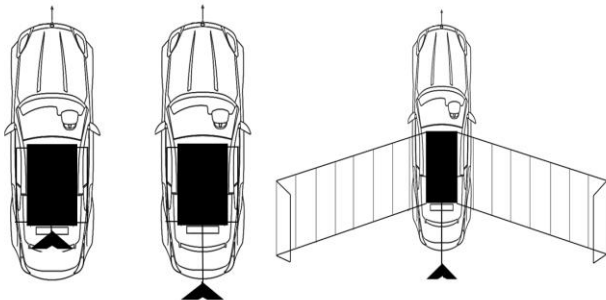

Figure – 2(d), Glider typed flying car mechanism at glance.

3. Advantages & Future Scope

1. the big task of the current century is transportation that can be made easily using flying cars over the geographical conditions where transportation is a hectic process in difficult areas and roads in our country such as valley, hills and forest areas, swamp and snow places.

2. As an alternative for airplane, boating, using flying cars for completing the tasks of the oil, mining, exploration, development, and environmental monitoring of large area of the rivers and lakes is not only economic and practical but also efficiency in usage.

3. In the future, flying car can be used as a communication network platform that can be used as an integrated information network and mechanized equipment, and also as a composition of intelligent network platform.

4. It can be used largely in the area of agriculture and forestry operations, mainly in the forest fires, drought, flood disasters and earth quakes and other emergencies when used for aerial observation and emergency.

5. It can be used as a special region of police patrols, medical emergencies and for some other needs.

6. In the upcoming years, jet engine can be used which makes the car to go in air for longer distance irrespective of altitude.

4. CONCLUSION

Irrespective of countries, from decades, one of the main problem in transportation is traffic jam/blockage's. Since from the automobile era to the current century, there was a lot of designs on flying cars. Although several designs are not conventional to manufacture with the current technology. The transportation problems are increasing daily causing plethora of problems especially in health care and military sector. Thus, this conceptualized design provides one of the solution using glider technology. This model has ability to move on the road like a normal and go on air with the wings like an aircraft. Moreover, it is nature friendly which reduce the cutting of trees to built new roads.

REFERENCES

- [1] YipingLin, in: Traffic and transportation, 26 (6) (2010), p.53.In Chinese.
- [2] Saeed, N., Al-Naffouri, T. Y., & Alouini, M. S. (2021). Wireless communication for flying cars. *Frontiers in Communications and Networks*, 2, 16.
- [3] de Matteis, G. (1991). Dynamics of hang-glidern. *Journal of guidance, control, and dynamics*, 14(6), 1145-1152.
- [4] Dees, P. (2010, September). Hang glider design and performance. In 10th AIAA Aviation Technology, Integration, and Operations (ATIO) Conference (p. 9300).
- [5] Shi, X., Kim, K., Rahili, S., & Chung, S. J. (2018, December). Nonlinear control of autonomous flying cars with wings and distributed electric propulsion. In 2018 IEEE Conference on Decision and Control (CDC) (pp. 5326-5333). IEEE.
- [6] Wang, Y. F., & Su, T. X. (2014). Autobody modelling analysis of the flying cars. In *Applied Mechanics and Materials* (Vol. 577, pp. 1310-1313). Trans Tech Publications Ltd.