

# A Review on Distribution Side STATCOM for VAR and Harmonic Compensation

Prakash<sup>1</sup>, Salik Ram Dewangan<sup>2</sup>

<sup>1,2</sup>Dept. of Electrical Engineering, RSR Rungta College of Engineering and Technology, Bhilai, C.G., India

\*\*\*

**ABSTRACT:** With the expanded utilization of force electronic for ac-to-dc converters, electrical conveyances frameworks are encountering an expanded in non-straight loads. These non-direct loads, like the traditional rectifier, drawn on-sinusoidal flows which will in general perniciously affect the force nature of the advanced A dispersion frameworks. The collaboration of non-sinusoidal flows with the framework impedance prompts mutilated framework voltage which can antagonistically affect different gadgets associated with the network. The joining of disseminated energy assets (DERs) with the dispersion power network can additionally compound the har-monic power issues. The conventional techniques for remuneration are at this point not satisfactory and consequently it is important to foster a way to give nearby receptive and consonant pay at the wellspring of the force quality issue inside the low-voltage conveyance organization. This article examines the utilization of a capacitor-less circulation static simultaneous compensator (D-STATCOM) for power quality remuneration in present day appropriation frameworks. The proposed geography depends on a network converter (MC), constrained by limited control set model prescient control (FCS-MPC) which utilizes inductive energy stockpiling instead of electrolytic capacitors, which have been demonstrated to be the most disappointment inclined parts in a force electronic circuit. Recreation and test results are pre-sented to approve the adequacy of the methodology.

**KEYWORDS:** Index Terms, Distribution Static Compensator (DSTATCOM), Power Quality, Custom Power

## 1. INTRODUCTION:

Force Quality (PQ) is a term which overall suggests supporting nearby sinusoidal waveform of power arrangement transport voltages at allowed voltage and repeat. Force Quality (PQ) connected issues are of most concern now a days. The power quality is seriously vexed considering the using nonlinear and dynamic weights and various weaknesses in power structure widely. Also, the controlling stuff and electronic contraptions subject to PC advancement request more huge degrees of power quality. This sort of devices are delicate to little changes of power quality, a short period of time change on PQ can cause phenomenal productive setbacks. Because of these reasons, paying little heed to for the power business, gear makers or for electric power customers, power quality issues had turned into an issue of extending interest. Under the situation of the freedom of power industry and relentless market, as the crucial person of product, power quality will impact the expense of power clearly in not really far off future. The fundamental force quality wordings characterized by IEEE Standard 1159-1995, regions follows: Voltage plunge, Voltage hang, Under voltage, Voltages well, Over voltage, Voltage

spikes', 'motivations' or 'floods', Music and Glints.

Custom force gadgets assume a significant part to over come the force quality related issues happening in the transmission and dissemination network framework. Custom power devices expect a critical part to beat the power quality related issues occurring in the transmission and allotment network structure. Custom power devices is a framework which is normally engaged to fragile arranged customers, and is familiar lately and arranged fundamentally with meet the necessities of mechanical and business customer. One of the principle benefits of custom force gadgets is to guarantee a more noteworthy dependability and a superior nature of force stream to the heap places in the circulation framework by effectively repaying forvoltage lists, plunges, floods, enlarge, consonant mutilations, interferences and glimmer, which are the regular issues related with appropriation lines.

Custom power contraptions vanquish the huge power quality issues by the strategy for injecting dynamic just as responsive power(s) into the system. The possibility

of custom power contraptions is to use solid state power electronic sections or static controllers in the medium voltage apportionment system wanting to supply strong and extraordinary ability to fragile customers.

Power electronic valves are the reason of those custom power contraptions, for instance, converter-based devices, which can be isolated into three social occasions:

- Series regulators (a model is Static Compensator: STATCOM),
- Shunt regulators (a model is Dynamic Voltage Restorer: DVR), and
- Joined Series-Shunt regulators (a model is Brought together Force Quality Conditioner UPQC).

Among Custom force gadgets, the shunt controllers have shown achievability in term of cost-adequacy in a wider range of issue solving from transmission to distribution levels. In such manner, Static Synchronous Compensator (STATCOM) is a powerful arrangement of power quality issues [10]. STATCOM frameworks are utilized in dispersion and transmission frameworks for various purposes. The STATCOM introduced in appropriation frameworks or close to the heaps to improve power factor and voltage guideline is called D-STATCOM. D-STATCOMs have quicker reaction when contrasted and transmission STATCOMs [11].

Much exploration affirms a few benefits of D-STATCOM contrasted with other custom force gadgets. These benefits incorporate [16]:

- Size, weight and cost decrease.
- Equality of slacking and driving yield.
- Precise and persistent receptive force control with quick reaction.
- Possible dynamic consonant channel capacity.

Conveyance Static Compensator (DSTATCOM) can overcome the issue of restricted band width, higher a loof component tally which causes expanded size and

misfortunes, and more slow reaction of Static Var Compensators (SVC) and it is finished by exact control and quick reaction during transient and consistent state, with lower impression and weight. The DSTATCOM has arisen as a promising gadget to give answer for voltage related issues and furthermore serving a large group of other current related force quality issue's answers like voltage guideline, load adjusting, responsive force remuneration, power factor revision and improvement and current symphonious control [2].

In this paper, different geographies and distinctive control strategies of DSTATCOM is exhibited for voltage guideline or force factor revision by responsive force remuneration alongside sounds disposal and burden adjusting.

## 2. DISTRIBUTION STATIC COMPENSATOR

This is a shunt associated gadget that has the same structure as that of a STATCOM and associated with the point of normal coupling (PCC) in conveyance system having lopsided and nonlinear loads and is shown in Fig. 1. This can perform load remuneration, i.e., power factor rectification, consonant separating, load adjusting and so forth when associated at the heap terminals. The primary Capacity of DSTATCOM is to supply receptive force (according to prerequisite) to the framework to manage the voltage at the PCC. Dynamic force waterway so be provided if a capacity battery or fly wheel is accessible on dc-side of the DSTATCOM [2],[3]

The different part of DSTATCOM is voltage source converter, dc transport capacitor, transformer and wave factor. The VSC changes over a dc voltage into a three-stage AC voltage and synchronized with PCC through a tie reactor and capacitor. The transformer is utilized to coordinate with the inverter yield to the line voltage [6],[7].

## 3. Different DSTATCOM topologies:

The DSTATCOM can be ordered on the foundations of various geographies, number of exchanging gadgets and on the foundations of impartial current remuneration and so on These DSTATCOMs are created to meet the prerequisites of various

applications in circulation framework. Two kinds of order is examined in this paper.

### Converter Grouping

DSTATCOM uses either a voltage-source inverter (VSI) or a current-source inverter (CSI). Voltage source inverter utilize capacitive energy stockpiling, while Current source inverter utilize inductive energy stockpiling in their separate dc joins for voltage and current [3]. Nonetheless, the voltage source inverters are extensively used because of the less warmth dispersed, more modest size, and the less expense of the capacitor contrasted with the inductor, utilized in the CSI, for a similar force rating [4]. The VSI associated in shunt with the air conditioner framework gives multifunctional geography which can be utilized for various points like voltage guideline and pay of responsive force, revision of force factor and end of current sounds [36]. Voltage source inverter (VSI) geography is well known in light of the fact that it tends to be expandable to staggered, multistep and multichain geography to upgrade the presentation with lower exchanging recurrence and expanded force taking care of limit. Different staggered geographies are Diode clasp staggered inverter, Full H-bridge & Flying capacitor staggered inverter regions.

### Diode-Clamped Multilevel Inverter:

The most generally utilized staggered geography is the diode cinched inverter, in this geography the diode is utilized as the clamping gadget to clip the dc transport voltage in order to accomplish steps in the yield voltage. Accordingly, the principle idea of this inverter is to use diodes to restrict the force gadgets voltage stress. The voltage over every capacitor and each switch is  $V_{dc}$ . An  $n$  level inverter needs  $(n-1)$  voltage sources,  $2(n-1)$  exchanging gadgets and  $(n-1)(n-2)$  diodes. The quality of the output voltage can be improved and the voltage waveform turns out to be nearer to sinusoidal waveform by expanding the quantity of voltage levels.

### Flying capacitor staggered inverter:

A very notable geography of staggered inverter is Flying Capacitor Staggered Inverter. It is very similar to diode braced staggered inverter. The capacitor must be pre-charged in this kind of staggered inverter. The geography comprises of diodes, capacitors and exchanging gadgets as displayed in fig. 2(c). This has been planned distinctly up to six degrees of voltage due to the reasonable limitations. Every leg comprises of exchanging gadgets which are in everyday semiconductors. Each inverter appendage comprises of cells associated in internal settled series. Each cell has two force switches and a solitary capacitor. Force switch is a blend of a semiconductor associated with an enemy of equal diode. Dissimilar to diode clasped inverter, this geography utilizes capacitors for clipping [34]. An inverter with  $N$  cell will have  $2N$  switches and  $N+1$  distinctive voltage levels including zero. We can likewise have negative voltage levels, and so all in everything we can say that  $N$  cell staggered inverter can give  $2N+1$  voltage levels. The voltage level is diminished as we move towards the heap. The number of level relies on the quantity of leading switches in every appendage. It is otherwise called Cursed Cell Inverter. Since the capacitors coasts as for earth's latent capacity, they are called Flying Capacitor.

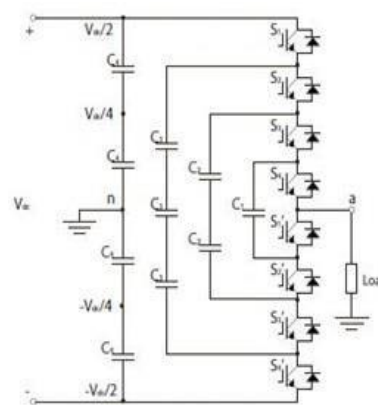

Fig.2: The flying capacitor multi level inverter

### H-Bridge VSI topology

It contains three H Extensions VSIs which are associated with a typical dc stockpiling capacitor. In this figure each switch addresses a force semi conductor

gadgets and an enemy of equal diode mix. Each VSI is associated with the organization through a transformer. Six yield terminals of the transformer are associated in star. These six terminals can likewise be associated in delta to repay a delta associated load. For this situation, every transformer is associated in corresponding with the relating load. The reason for including the transformer is to give separation between the inverter legs which forestalls the dc stockpiling capacitor from being shorted through switches in various inverters. The

Similarly, the charge can be transferred from the Capacitor  $C_{dc1}$  to the capacitor  $C_{dc2}$  by closing the switch  $S_{ch1}$  to build current in  $L_p$  and then charging  $C_{dc2}$

Through the diode  $D_{ch2}$  by opening the switch  $S_{ch1}$ .

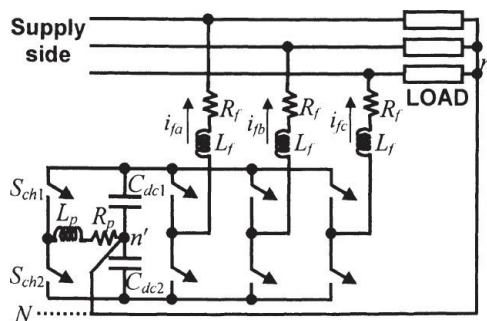

Fig.3. The neutral clamped three phase VSI topology

### Neutral-Clamped Three-Phase VSI topology

This geography comprise of a chopper circuit which is represented by the switches  $S_{ch1}$  and  $S_{ch2}$ , a diode  $D_{ch1}$  and  $D_{ch2}$  in equal and inductance and obstruction which are meant by  $L_p$  and  $R_p$ .

Leave the voltage across  $C_{dc1}$  alone  $V_{dc1}$  and voltage across  $C_{dc2}$  is  $V_{dc2}$ . Ordinarily the two switches are left open and along these lines two voltages  $V_{dc1}$  and  $V_{dc2}$  are equivalent. Presently assume there is a voltage drop in  $V_{dc1}$  because of this there is ascent of voltage in  $V_{dc2}$ . Current is developed in the inductor  $L_p$  because of shutting of switch  $S_{ch2}$  and when the current arrives at an unequivocal level, the switch  $S_{ch2}$  is opened, henceforth the inductor current get released through the diode  $D_{ch1}$  to raise the voltage  $V_{dc1}$  to the ideal level.

inductor  $L_f$  in this figure addresses the hole age inductance of every transformer and extra outside inductance. Copper loss of the interfacing transformer is addressed by an obstruction  $R_f$ , yet because of the presence of detachment transformers, this geography, nonetheless, isn't appropriate for pay of the heap flows containing dc parts, however, is not suitable for compensation of the load currents containing dc components.

### 4. CONCLUSIONS

A near investigation of the fundamental calculations utilized for control of DSTATCOM is introduced in this part. The benefits and faults of each plan are brought out by leading reproduction contemplates. It is tracked down that a DSTATCOM, regardless the calculation utilized, does receptive force pay, voltage guideline, consonant decrease, load adjusting and load evening out.

### REFERENCES

- [1] Om Prakash Mahela, Abdul Gafoor Shaik, "A review of distribution static compensator", Renewable and Sustainable Energy Reviews, Vol.50, pp.531-546, 2015.
- [2] Iyer S, Ghosh A, Joshi A., "Inverter topologies for DSTATCOM applications-a simulation study", Electric Power System Res, Vol. 75(23), pp. 161-70, 2005.
- [3] Eldery M, El-Saadany E, Salama M. "Dstatcom effect on the adjustable speed drive stability boundaries", IEEE Trans Power Deliv Vol. 22(2), pp.1202-9, 2007.
- [4] Ghosh A, Joshi A. "The concept and operating principles of a mini custom power park", IEEE Trans Power Deliv, Vol.19 (4), pp.1766-74, 2004.
- [5] Gupta R, Ghosh A, Joshi A. "Performance comparison of vsc-based shunt and series compensators used for load voltage control in distribution systems", IEEE Trans Power Deliv Vol. 26(1), pp.268-78, 2011.
- [6] Hussain S, Subbaramiah M. "An analytical approach for optimal location of dstatcom in radial distribution system", In: 2013 International conference on energy efficient technologies for sustainability (ICEETS), pp.

- 1365–9,2013.
- [7] Singh B, Arya S, Chandra A, Al-Haddad K. "Implementation of adaptive filter in distribution static compensator", IEEE Trans Ind Appl Vol.50 (5), pp.3026–36,2014.
- [8] Singh B, Jayaprakash P, Somayajulu T R, Kothari D, Chandra A, Al-Haddad K., "Integrated three-leg vsc with a zig-zag transformer based three-phase four wire dstatcom for power quality improvement", In: 34<sup>th</sup> annual conference of IEEE industrial electronics, IECON 2008, pp. 796–801,2008.
- [9] A. Ghosh, G. Ledwich, "Power Quality Enhancement Using Custom Power Devices", Norwell, MA ,USA: 2002.
- [10] Kasal G, Singh B., "Voltage and frequency controllers for an asynchronous generator-based isolated wind energy conversion system", IEEE Trans Energy Convers ,Vol.26 (2), pp. 402–16,2011.
- [11] Rohani A, Joorabian M., "Modeling and control of dstatcom using adaptive hysteresis band current controller in three-phase four-wire distribution systems", In: 5th Power electronics, drive systems and technologies conference (PEDSTC), pp. 291–7,2014.
- [12] Singh B, Arya S, Jain C, Goel S. , "Implementation of four-leg distribution static compensator", IET Gener, Transm Distribution Vol. 8(6) ,pp. 1127–39, 2014.